

[54] RAILROAD BRAKE PIPE HANGER

[76] Inventor: Clarke Reynolds, 16 St. Bernard La., Tiburon, Calif. 94920

[\*\*] Term: 14 Years

[21] Appl. No.: 660,333

[22] Filed: Feb. 23, 1976

[51] Int. Cl. .... D8-08

[52] U.S. Cl. .... D8/373; D8/380; D8/396

[58] Field of Search ..... D8/373, 380, 382, 394, D8/396; 248/68 CB, 67.5, 74 R, 58, 62

[56] References Cited

U.S. PATENT DOCUMENTS

2,890,848	6/1959	Johnson, Jr. ....	248/74 R
3,944,175	3/1976	Kearney .....	248/62
3,968,323	7/1976	Blanchet .....	248/68 CB

FOREIGN PATENT DOCUMENTS

544,618 4/1942 United Kingdom ..... 248/74 R

Primary Examiner—Wallace R. Burke  
Assistant Examiner—James M. Gandy  
Attorney, Agent, or Firm—Harvey G. Lowhurst

[57] CLAIM

The ornamental design for a railroad brake pipe hanger, as shown.

DESCRIPTION

FIG. 1 is a perspective view, taken from the left side and above, of a railroad brake pipe hanger showing my design it being understood that the broken lines are for illustrated purposes only;

FIG. 2 is a front elevational view thereof;

FIG. 3 is a side elevational view thereof;

FIG. 4 is a top plan view thereof; and

FIG. 5 is a bottom plan view thereof.

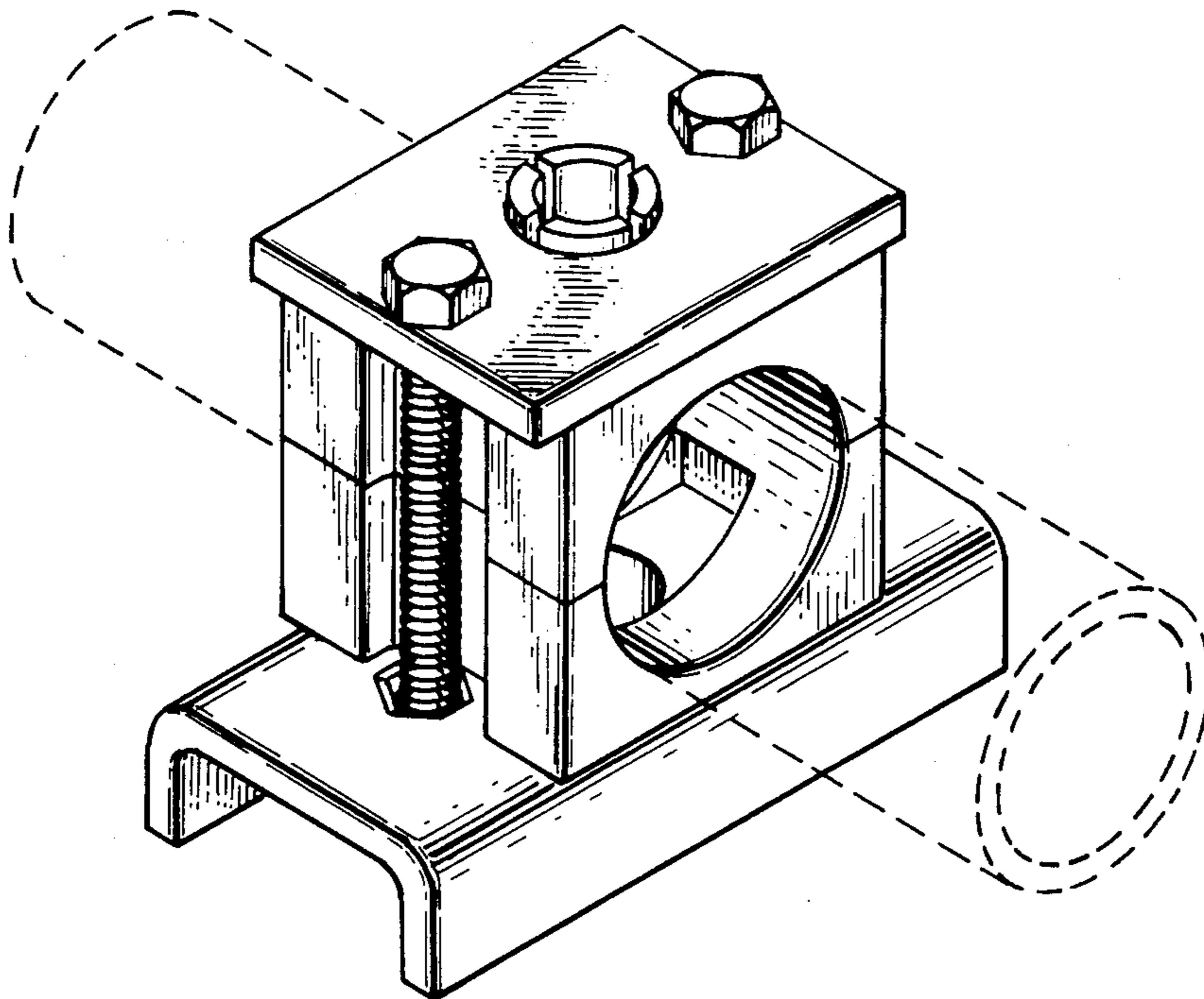

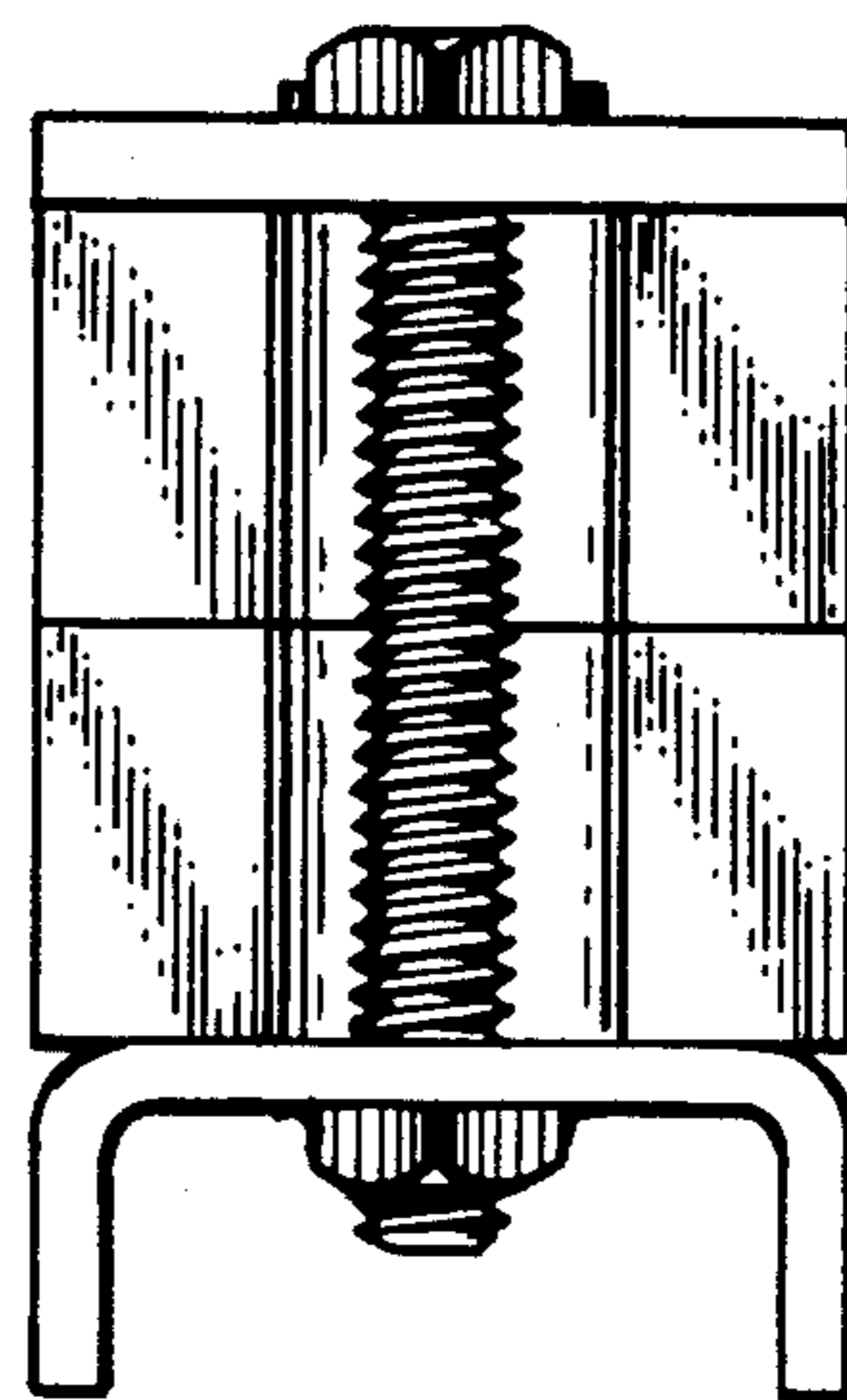
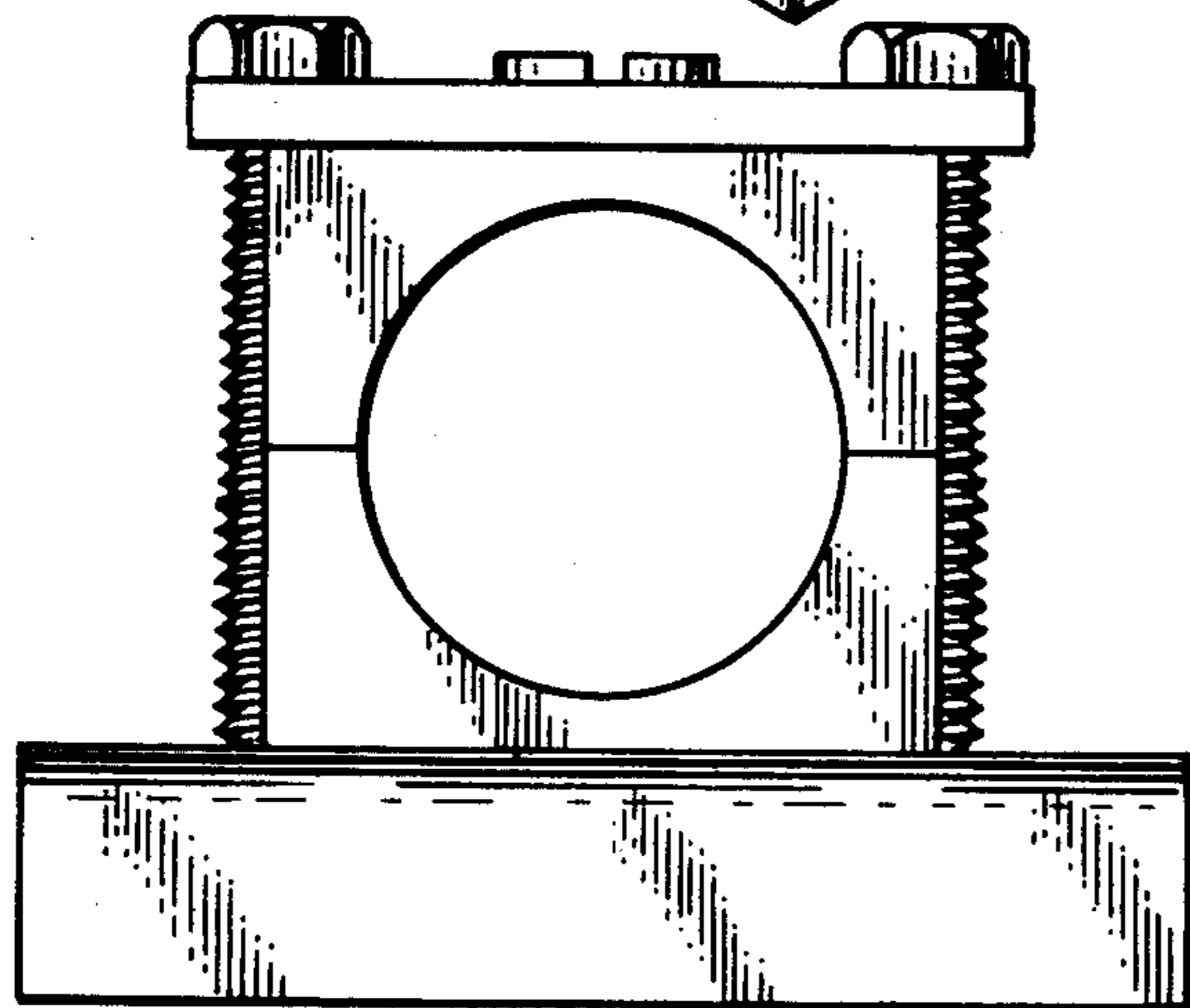
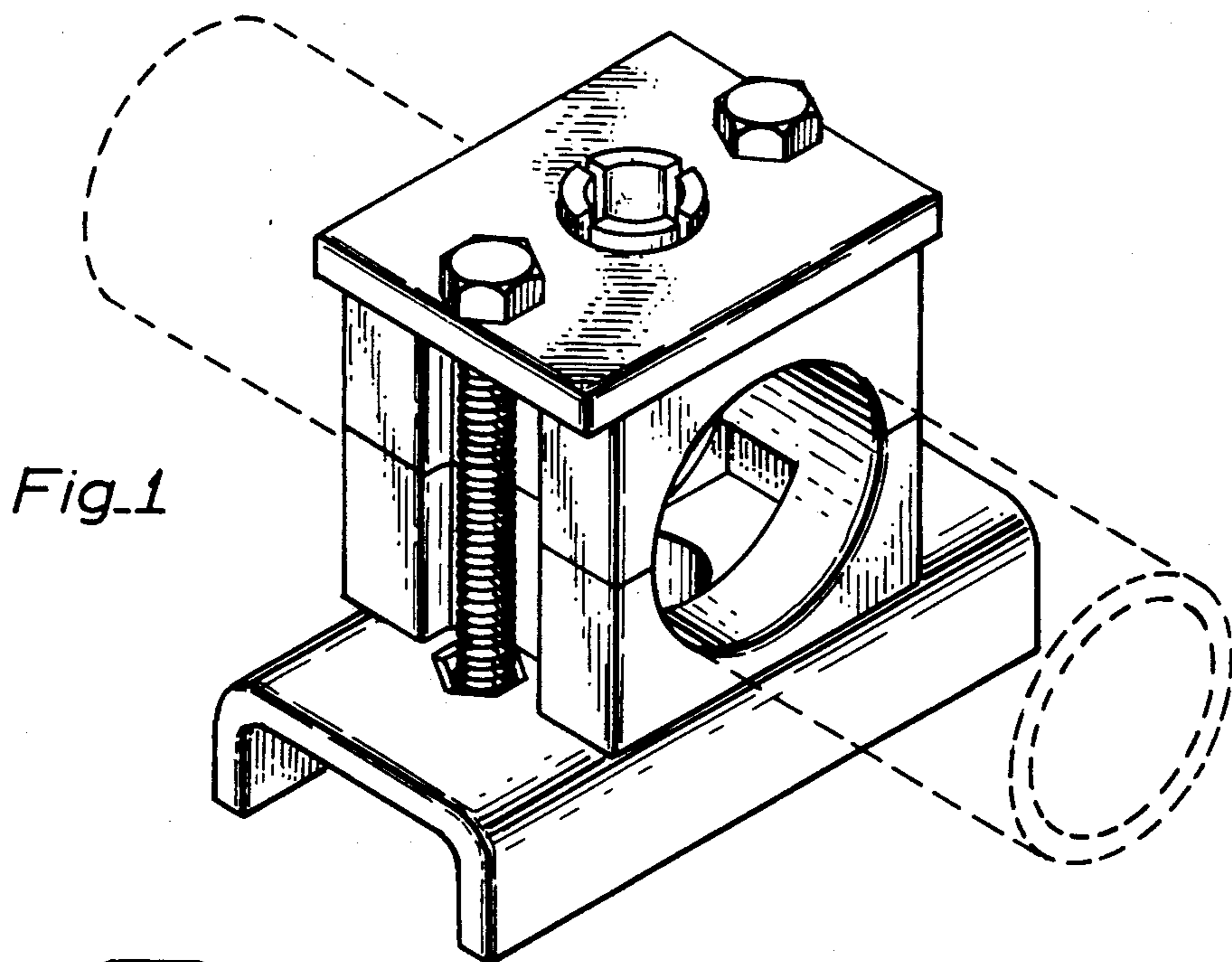

Fig. 2

Fig. 3

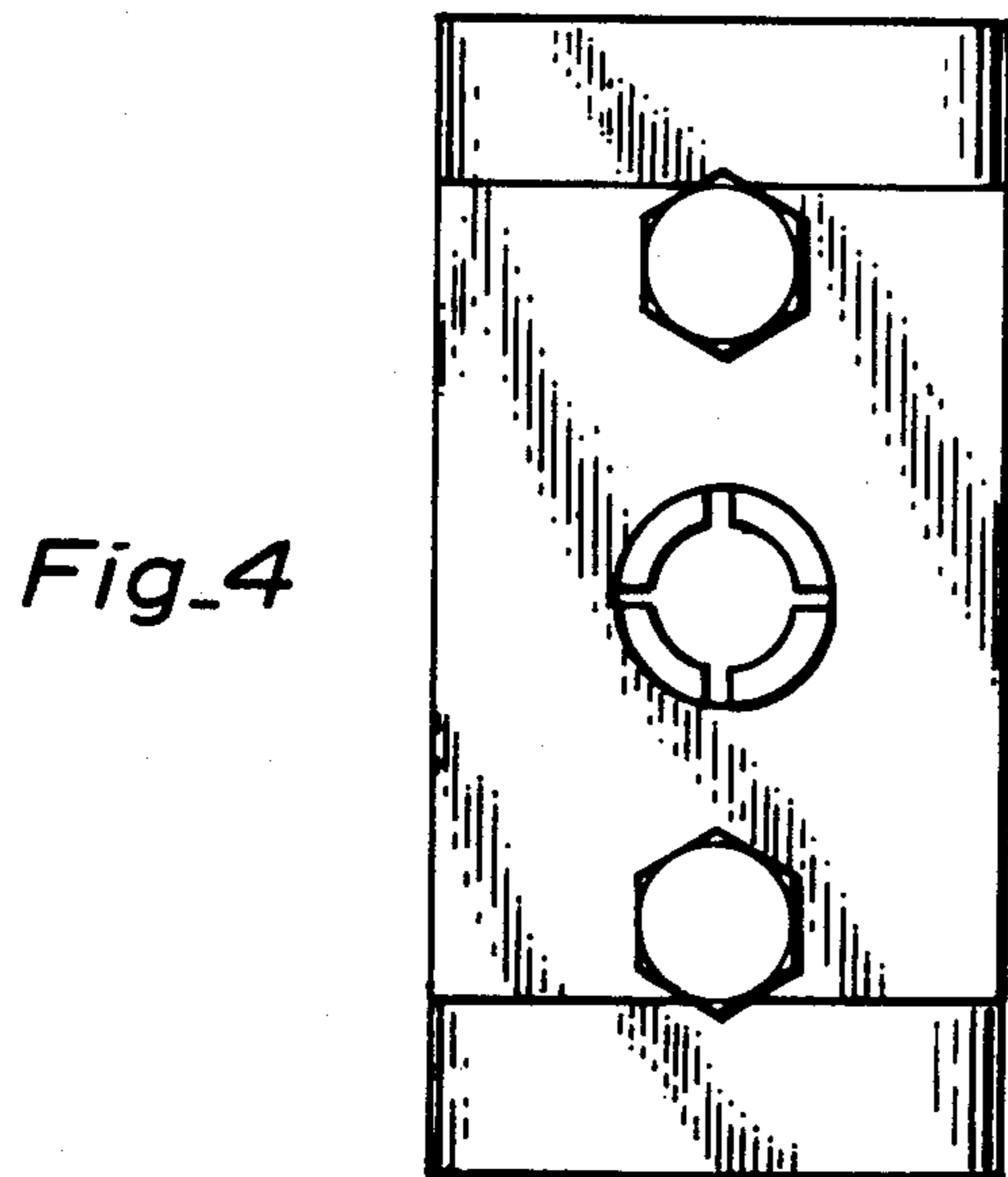

Fig. 4

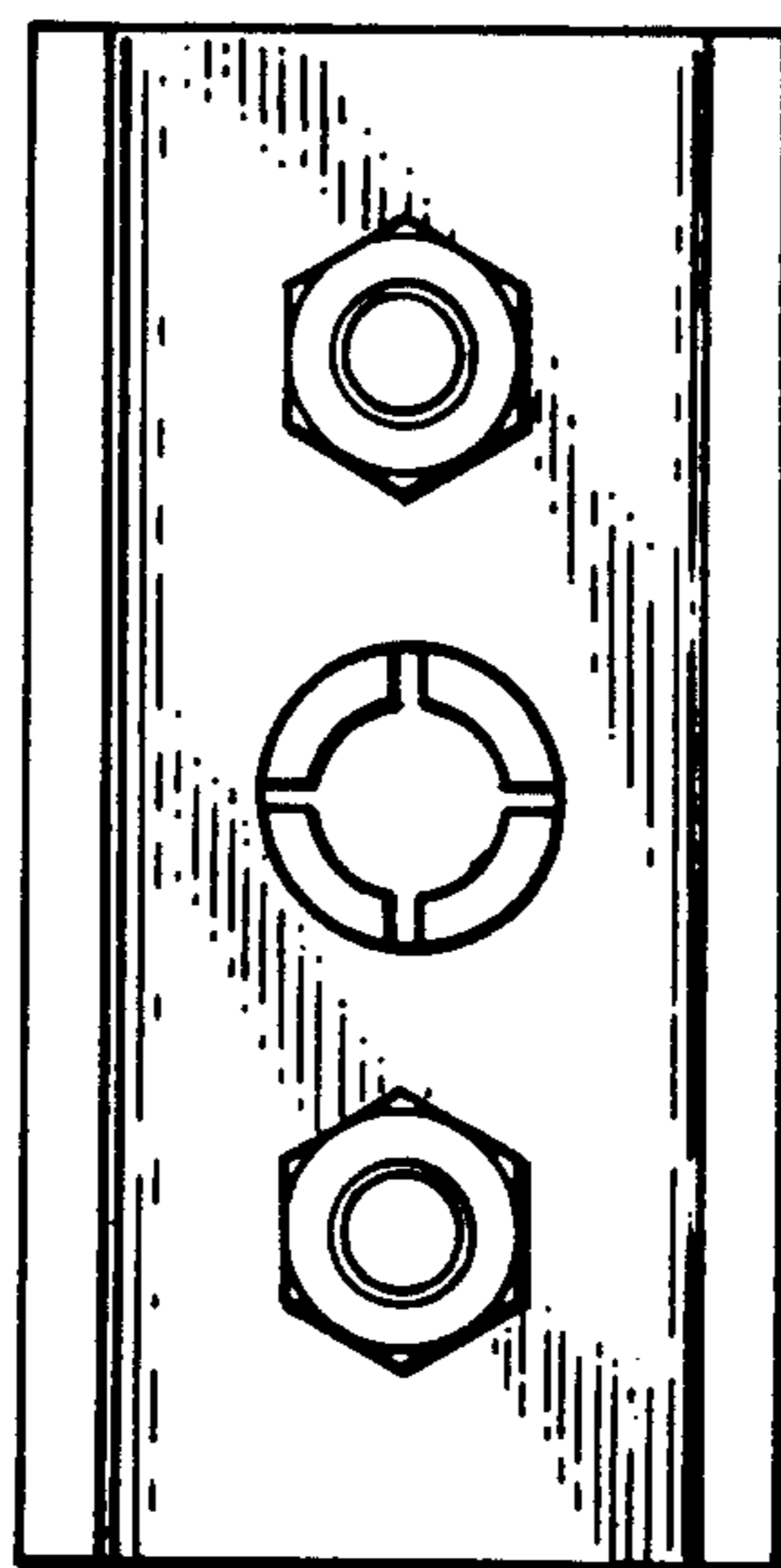

Fig. 5