

[54] DETACHABLE LUGGAGE CASE FOR A MOTORCYCLE

3,313,382 4/1967 Rosing et al. 190/53

[75] Inventor: John A. Warren, Jr., Yorba Linda, Calif.

[73] Assignee: Dan Gurney Cycle Products, Santa Ana, Calif.

[**] Term: 14 Years

[21] Appl. No.: 687,371

[22] Filed: May 17, 1976

[51] Int. Cl. D3-01

[52] U.S. Cl. D87/5 F

[58] Field of Search D87/1 R, 5 R, 5 F, 5 G; 190/41 R, 60, 52; D12/158; 224/31, 32 A, 39, 42.01, 43, 44

[56] References Cited

U.S. PATENT DOCUMENTS

- D. 172,328 1/1954 Barratt et al. D87/5 F
- D. 203,145 12/1965 Arbib D87/5 F
- 3,128,853 4/1964 Huffman et al. 190/41 R

OTHER PUBLICATIONS

A.M.F. Harley-Davidson Motorcycles & Access. Cat. No. 99457-75V, 1975 p. 5, Item D.

Primary Examiner—Joel Stearman
Assistant Examiner—George P. Word
Attorney, Agent, or Firm—George J. Netter

[57] CLAIM

The ornamental design for a detachable luggage case for a motorcycle, as shown and described.

DESCRIPTION

FIG. 1 is a perspective view of a detachable luggage case for a motorcycle showing my new design.

FIG. 2 is a right end elevational view.

FIG. 3 is a top plan view.

FIG. 4 is a front elevational view.

FIG. 5 is a bottom plan view.

FIG. 6 is a rear elevational view.

The characteristic feature of the design resides in the generally triangular protuberance on the front of the luggage case.

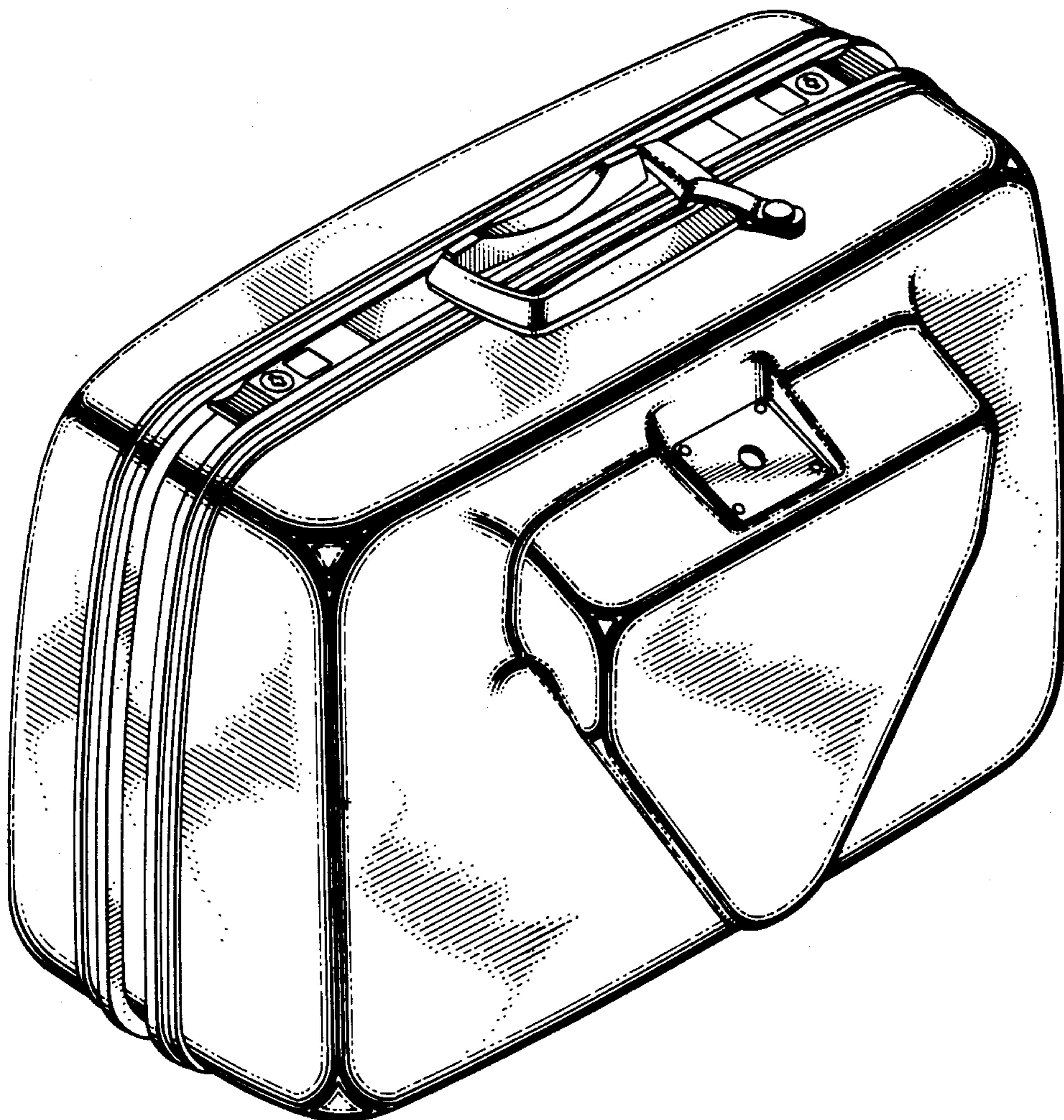

FIG. 1.

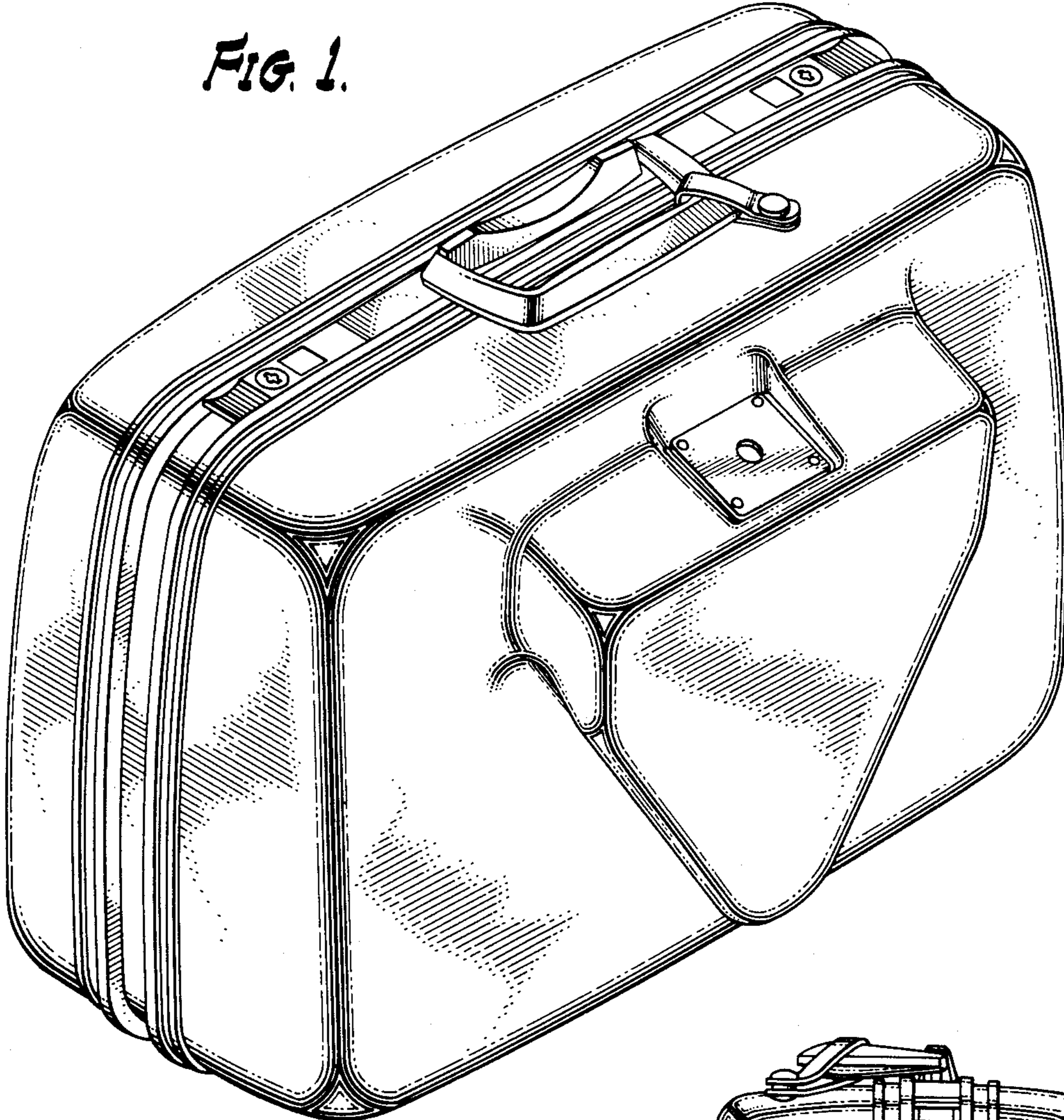
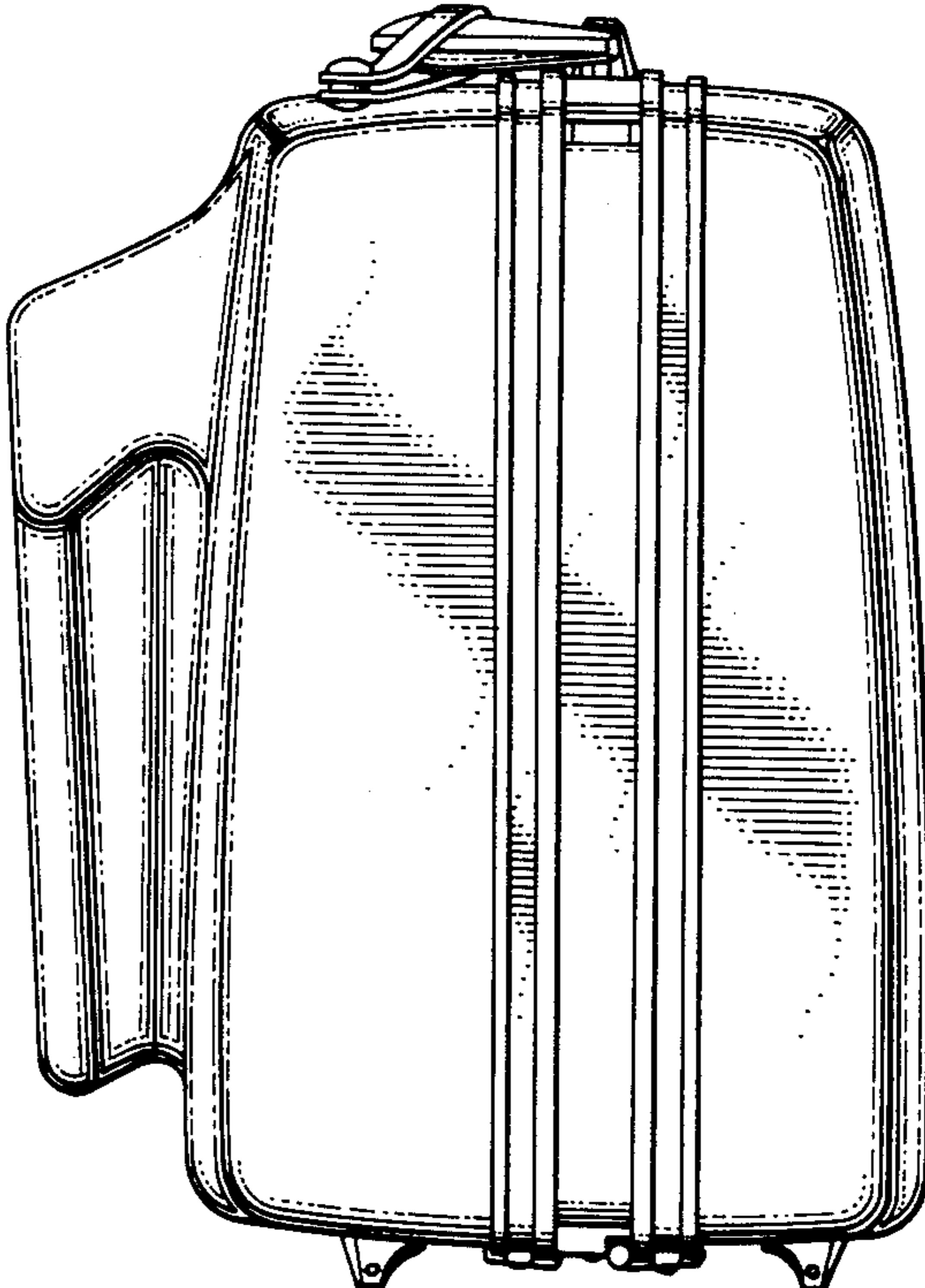

FIG. 2.



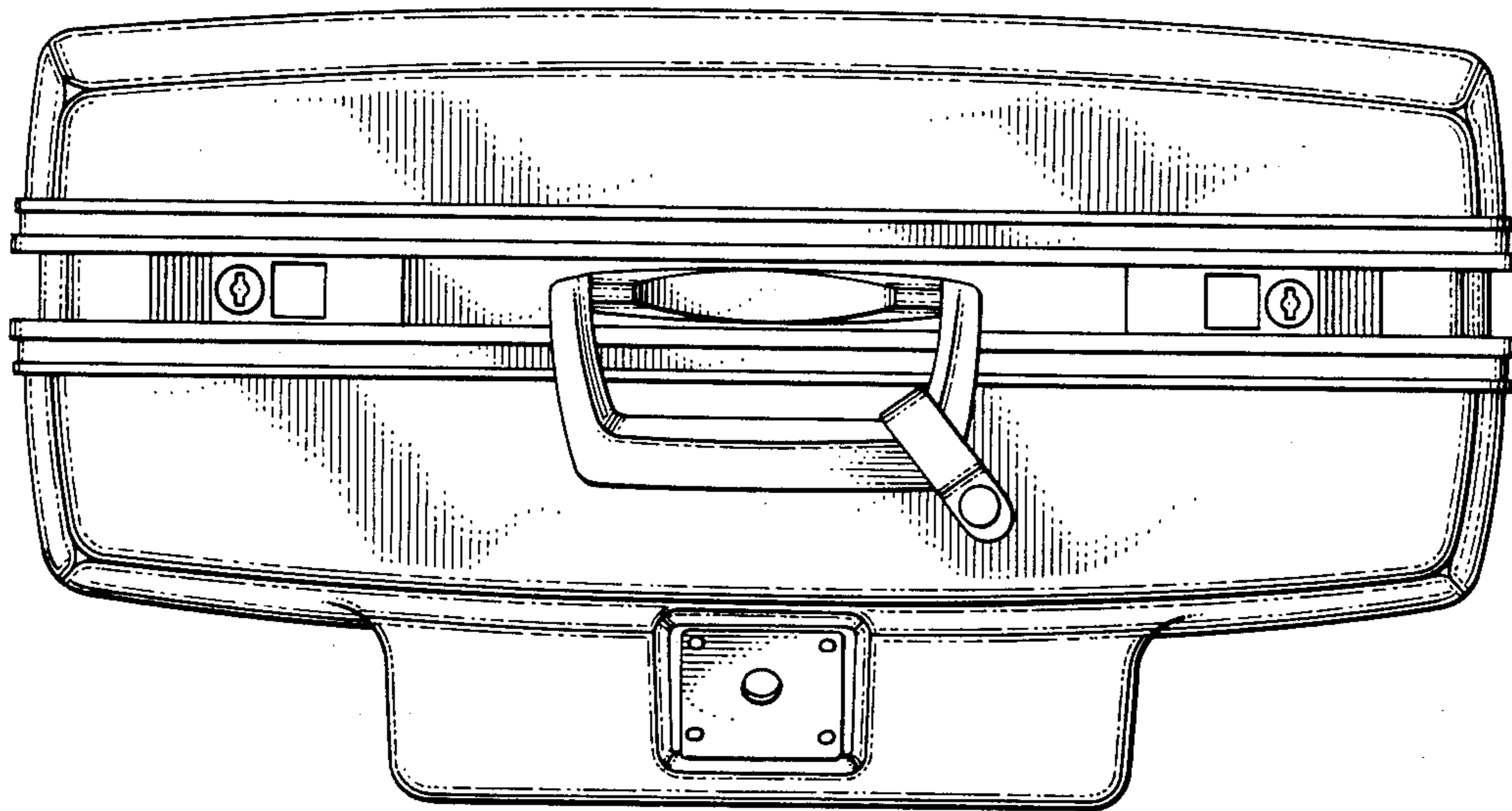

FIG. 3.

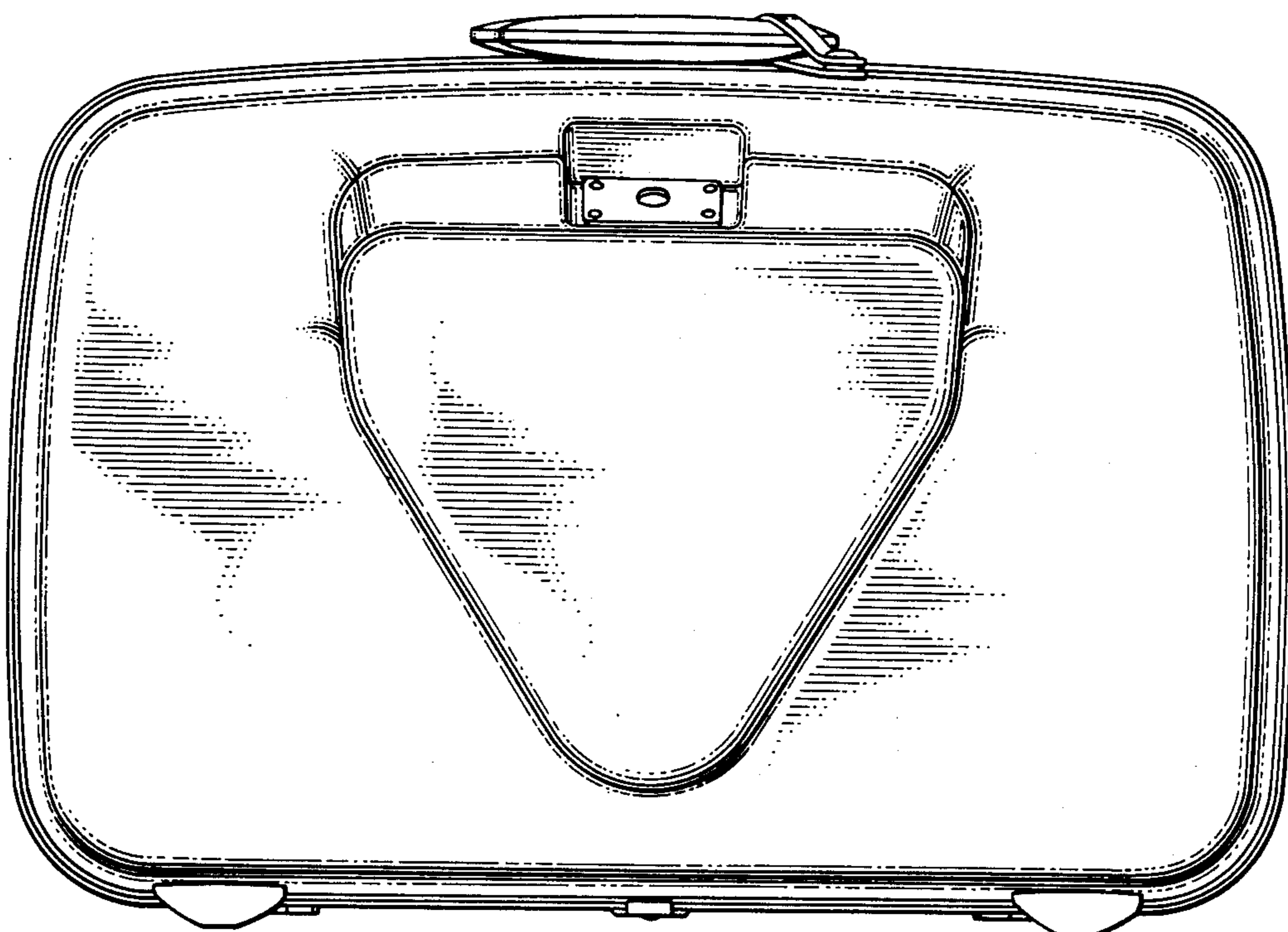

FIG. 4.

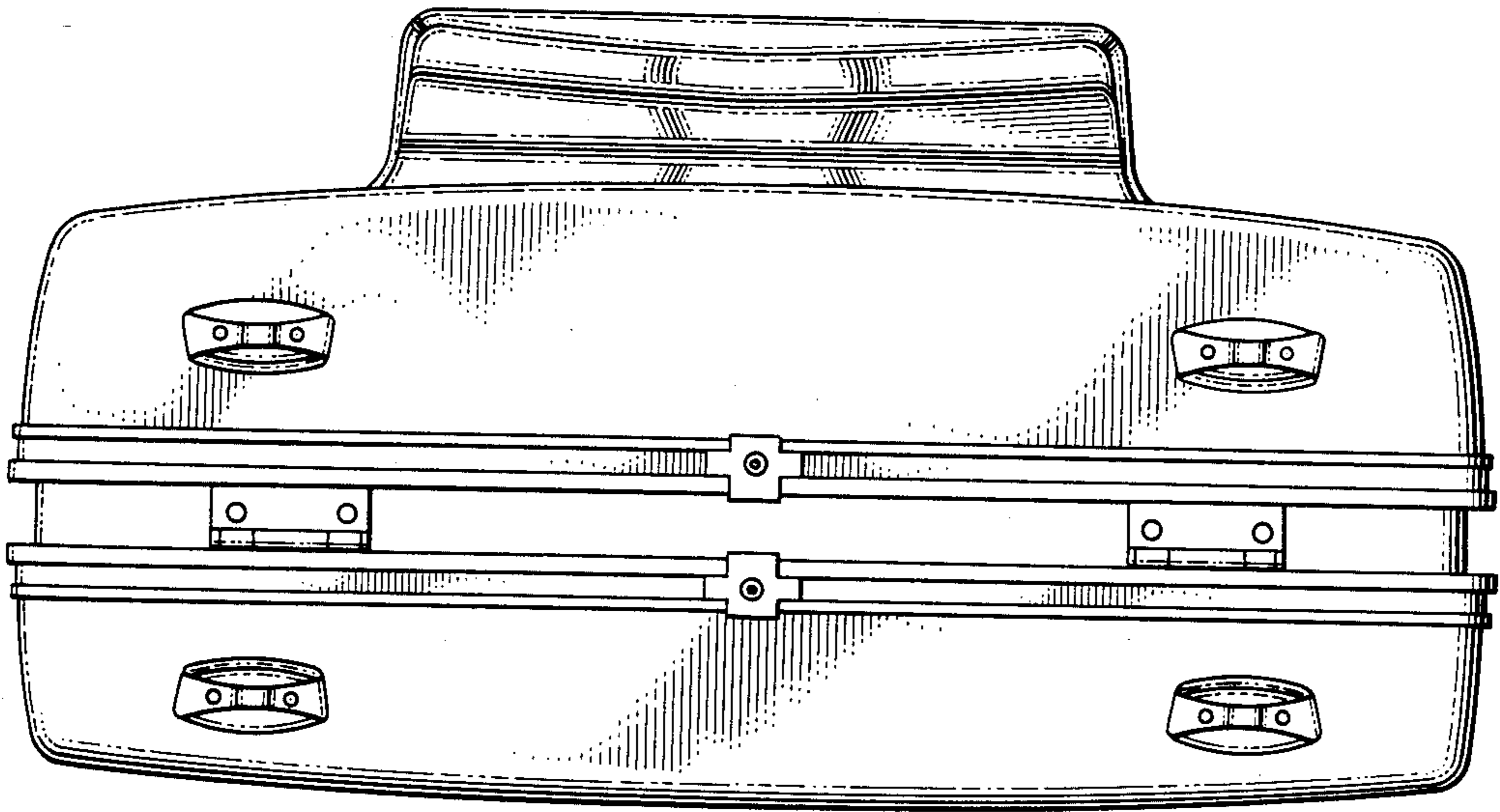

FIG. 5.

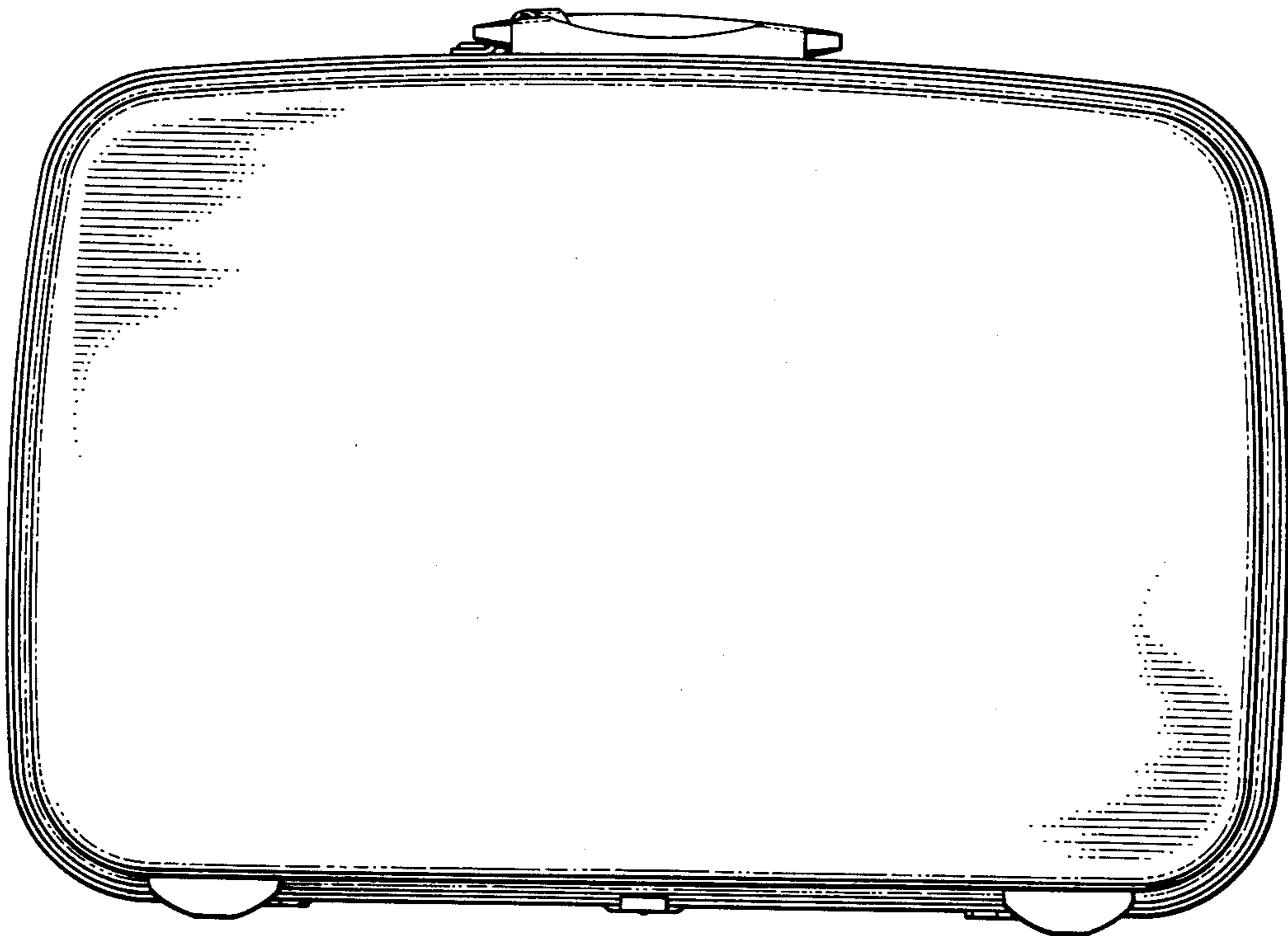

FIG. 6.