

[54] VAN OVERHEAD CONSOLE

[76] Inventor: **Buster D. Stewart**, 16123 Runnymede St., Van Nuys, Calif. 91406

[\*\*] Term: **14 Years**

[21] Appl. No.: **656,415**

[22] Filed: **Feb. 9, 1976**

[51] Int. Cl. .... **D12-16**

[52] U.S. Cl. .... **D12/155**

[58] Field of Search ..... D12/155, 192; 296/70, 296/1 R, 37; 180/90; 224/42.1 C, 42.42 R, 42.46 R, 29 R; 108/44, 47, 48; 312/245, 246, 7 R

[56] **References Cited**

**U.S. PATENT DOCUMENTS**

1,941,961 1/1934 Tichenor et al. .... 180/90

2,023,719 12/1935 Arrison ..... 180/90

3,773,378 11/1973 Lewis ..... D12/155

*Primary Examiner*—Wallace R. Burke  
*Assistant Examiner*—James M. Gandy  
*Attorney, Agent, or Firm*—Paul L. Gardner

[57] **CLAIM**

The ornamental design for a van overhead console, as shown and described.

**DESCRIPTION**

FIG. 1 is a perspective view of a van overhead console showing my new design.

FIG. 2 is a bottom plan view thereof.

FIG. 3 is a side elevational view thereof.

FIG. 4 is a right end elevational view thereof, and FIG. 5 is a left end elevational view thereof.

The top of the console is substantially plain and unornamented and follows the contour of the top edges shown in FIGS. 3, 4 and 5.

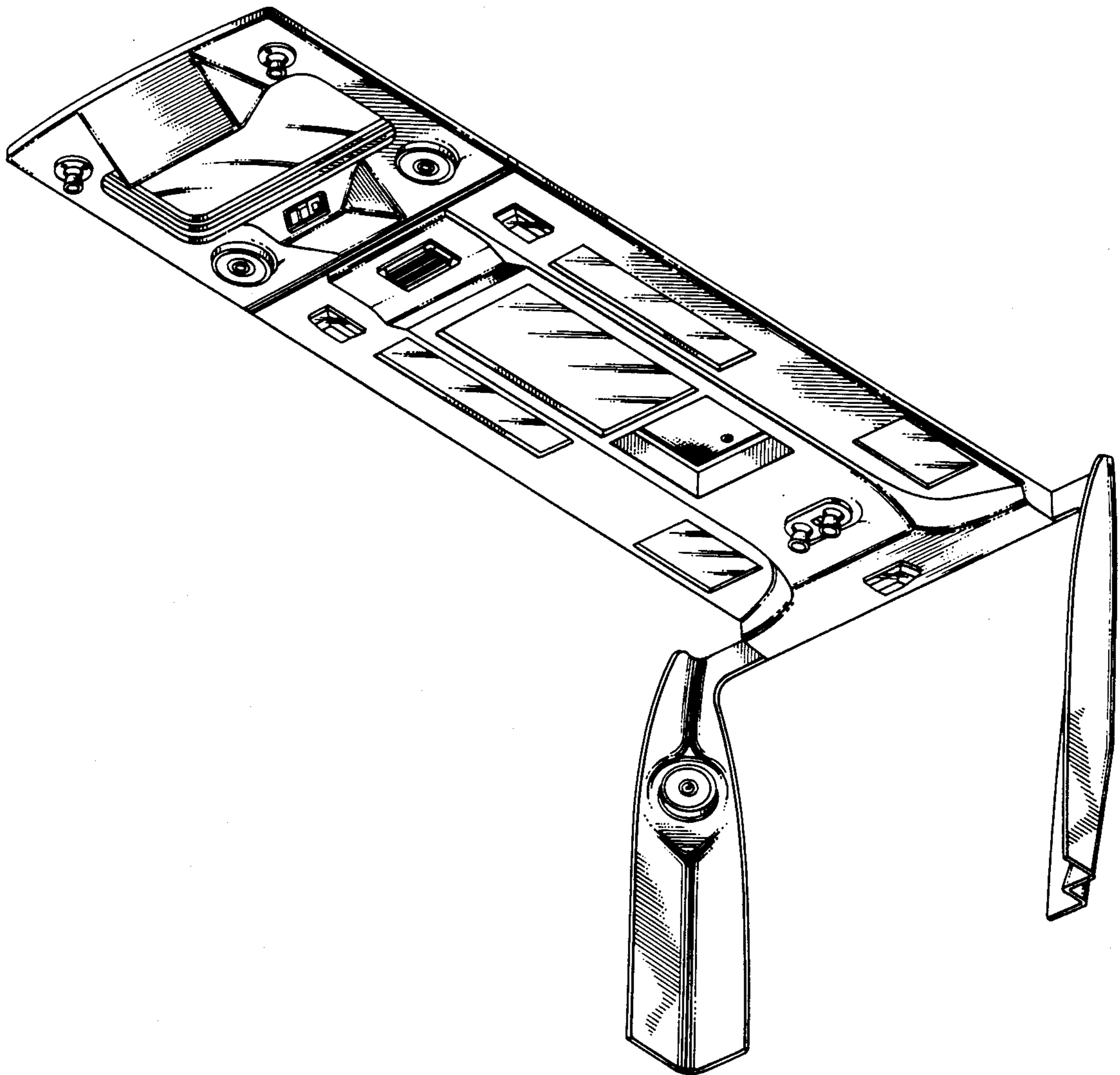

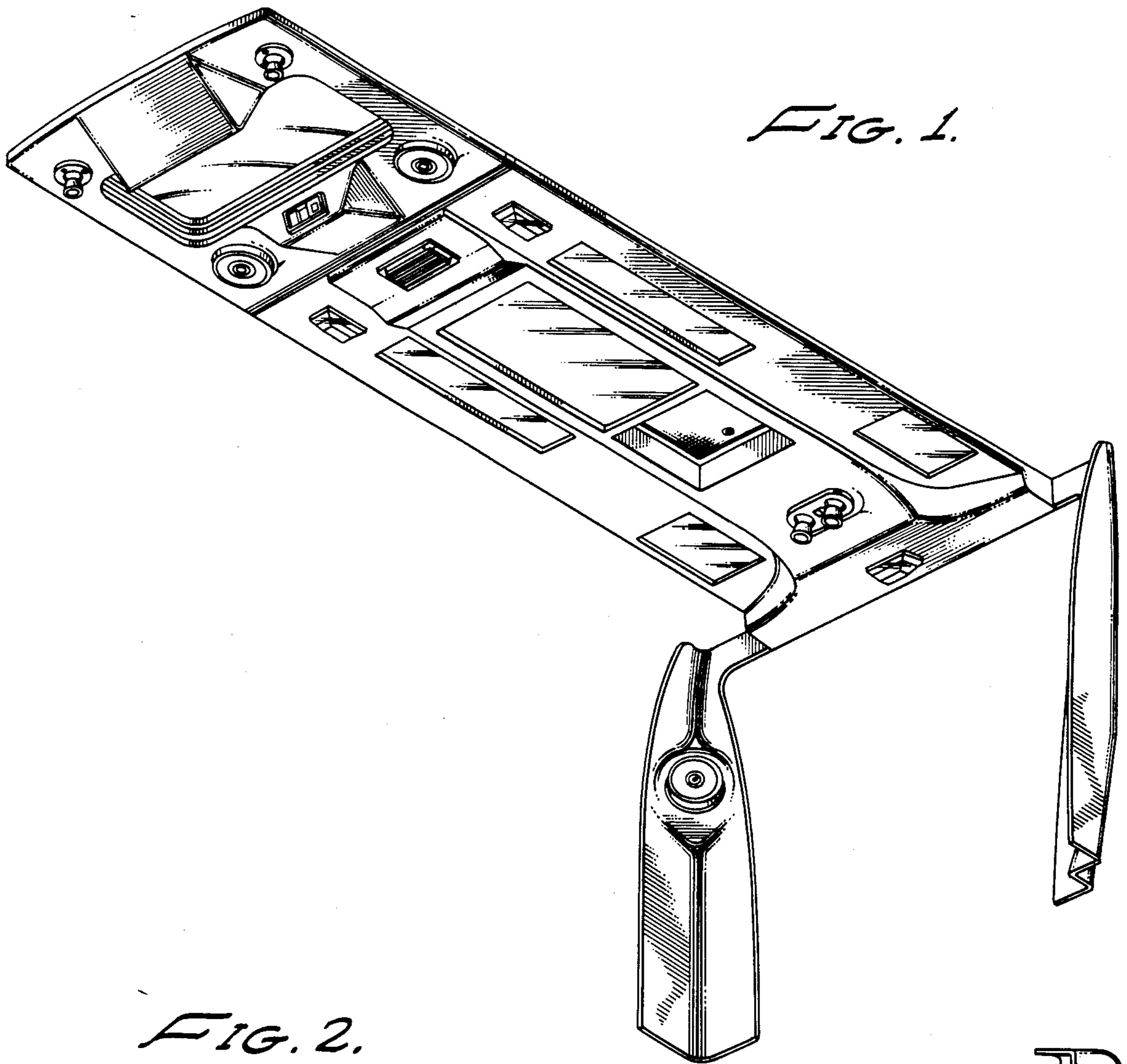
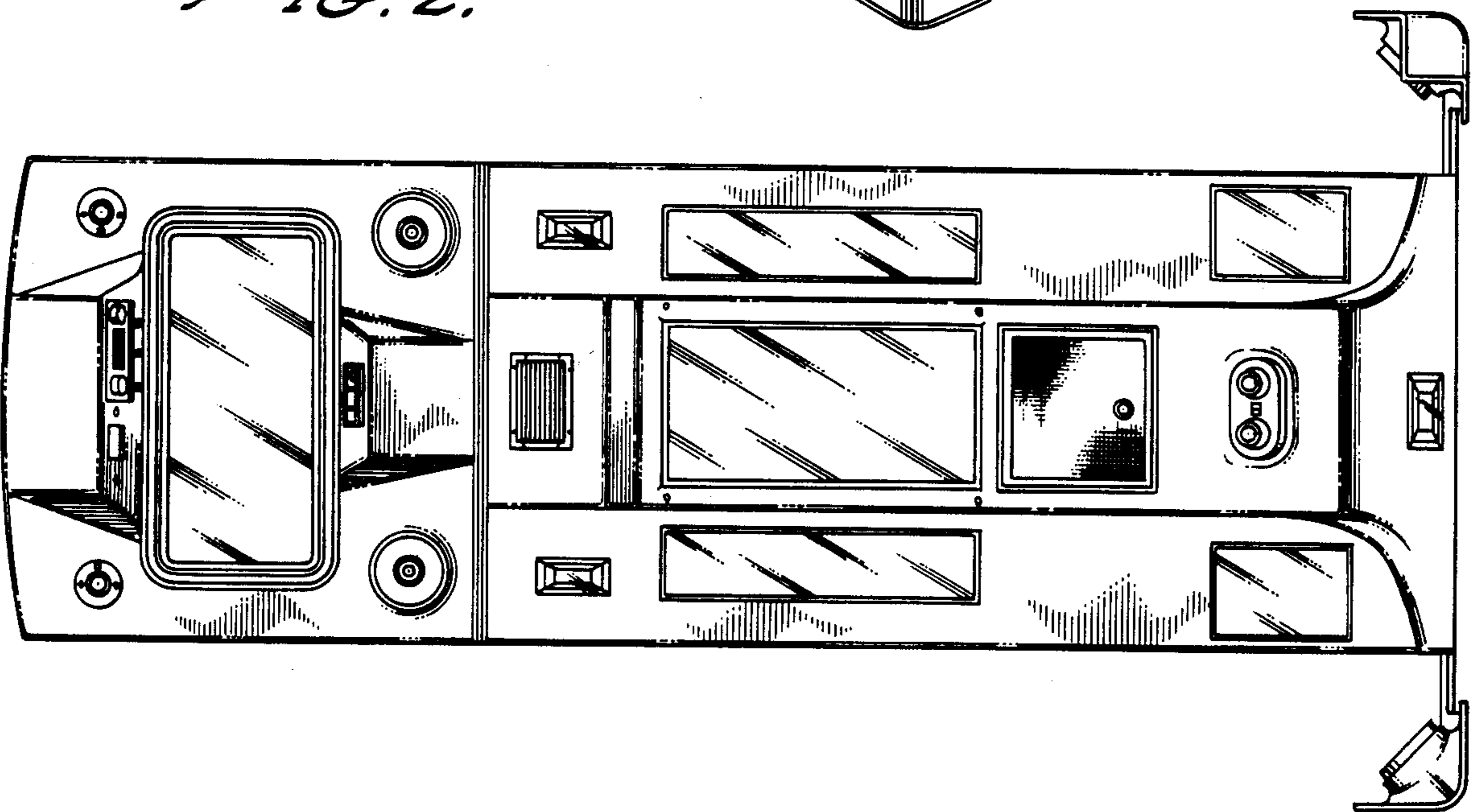
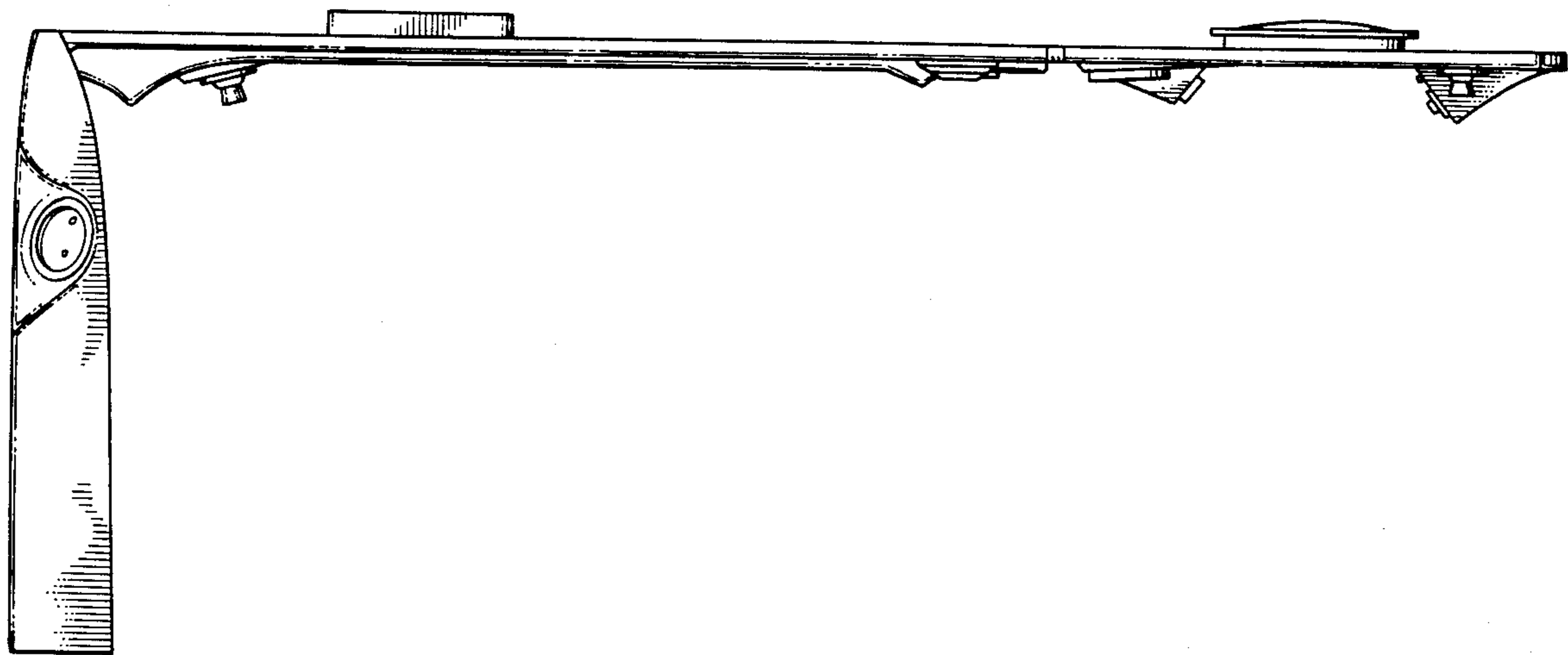
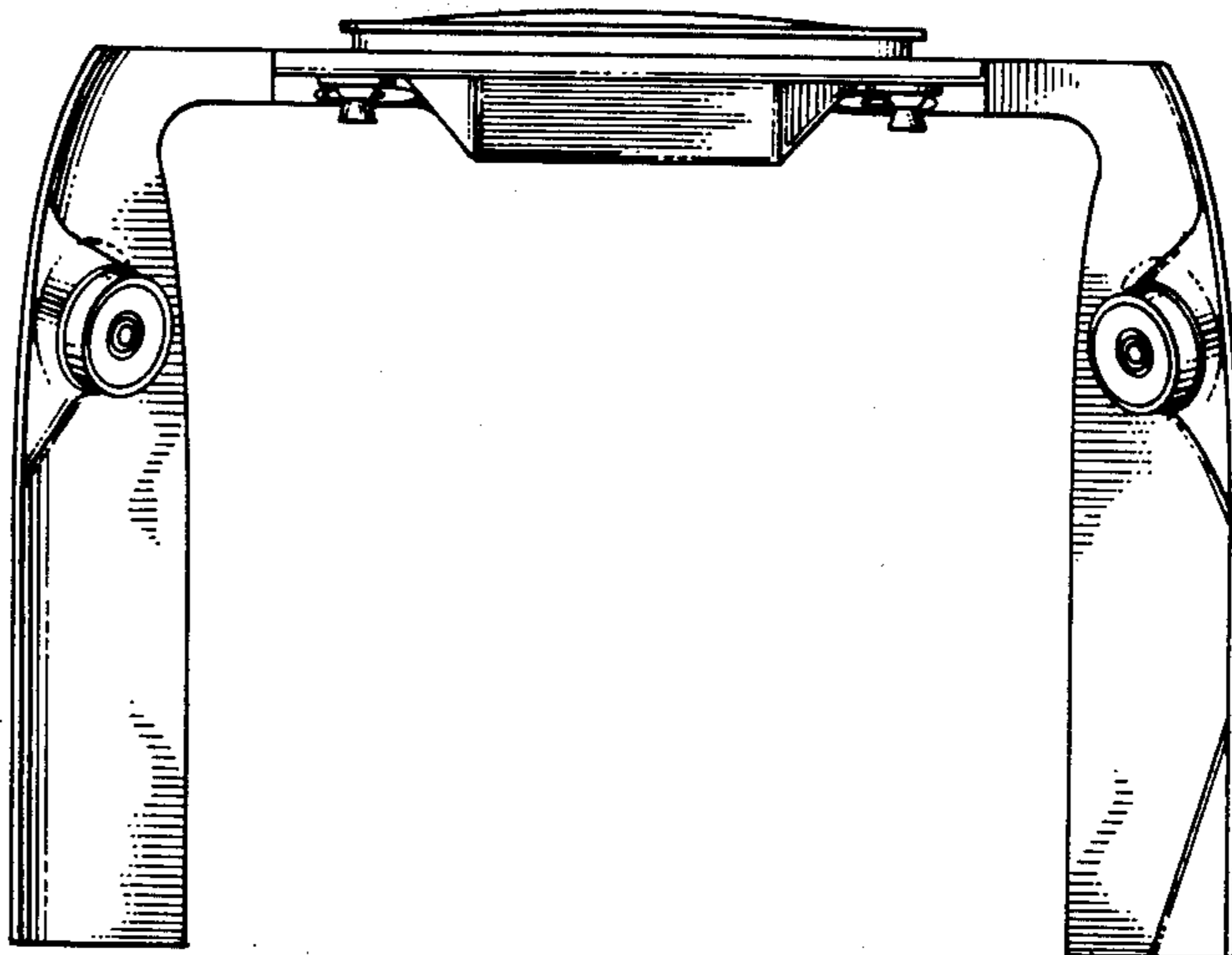

FIG. 2.

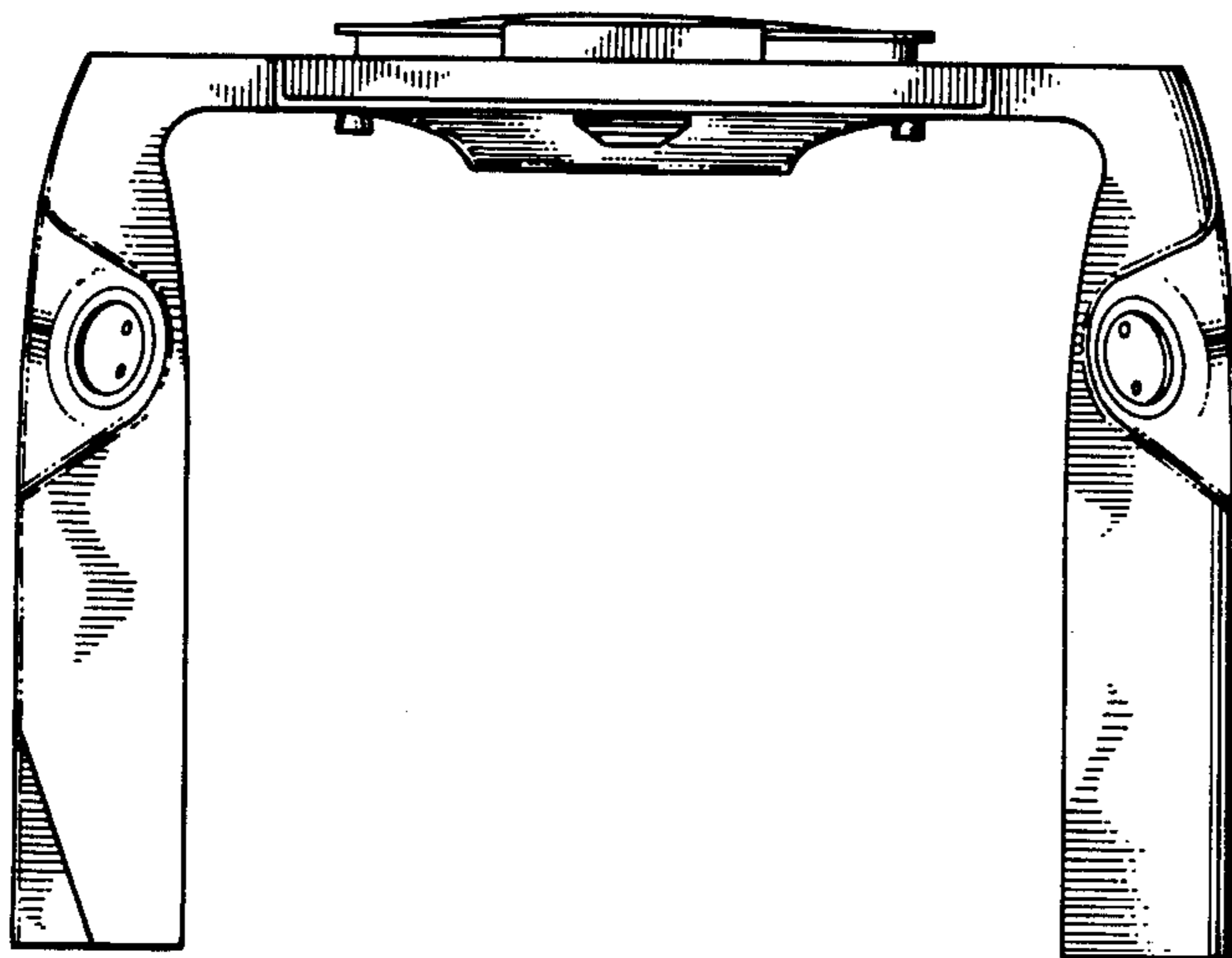



*FIG. 3.*



*FIG. 4.*



*FIG. 5.*