

United States Patent [19]

Paquette

[11] **Des. 246,593**

[45] **** Dec. 6, 1977**

[54] **DESK TOP HANGER FOR
SUSPENSION-TYPE DOCUMENT HOLDERS**

[75] Inventor: **Edmund T. Paquette, Shrewsbury,
Mass.**

[73] Assignee: **Wright Line Inc., Worcester, Mass.**

[**] Term: **14 Years**

[21] Appl. No.: **673,682**

[22] Filed: **Apr. 5, 1976**

[51] Int. Cl. **D19-02**

[52] U.S. Cl. **D19/90**

[58] Field of Search **D19/90-91,
D19/65, 75, 86, 95; D6/142, 85, 99, 100;
248/175; 211/37, 42, 11, 181**

[56] **References Cited**

U.S. PATENT DOCUMENTS

D. 151,272 10/1948 Kipp **D6/100**

D. 160,144 9/1950 Brown **D6/85**
D. 212,291 9/1968 Hamilton et al. **D6/85**
D. 240,421 7/1976 Rose **D19/90**
D. 241,197 8/1976 Covell et al. **D6/85**
3,098,488 7/1963 Schnelle **211/181**

Primary Examiner—Joel Stearman
Assistant Examiner—George P. Word
Attorney, Agent, or Firm—Robert J. Schiller

[57] **CLAIM**

The ornamental design for a desk top hanger for suspension-type document holders, substantially as shown and described.

DESCRIPTION

FIG. 1 is a perspective view of a desk top hanger for suspension-type document holders embodying my new design;

FIG. 2 is a left side elevational view;

FIG. 3 is a front elevational view;

FIG. 4 is a top plan view; and

FIG. 5 is a bottom plan view.

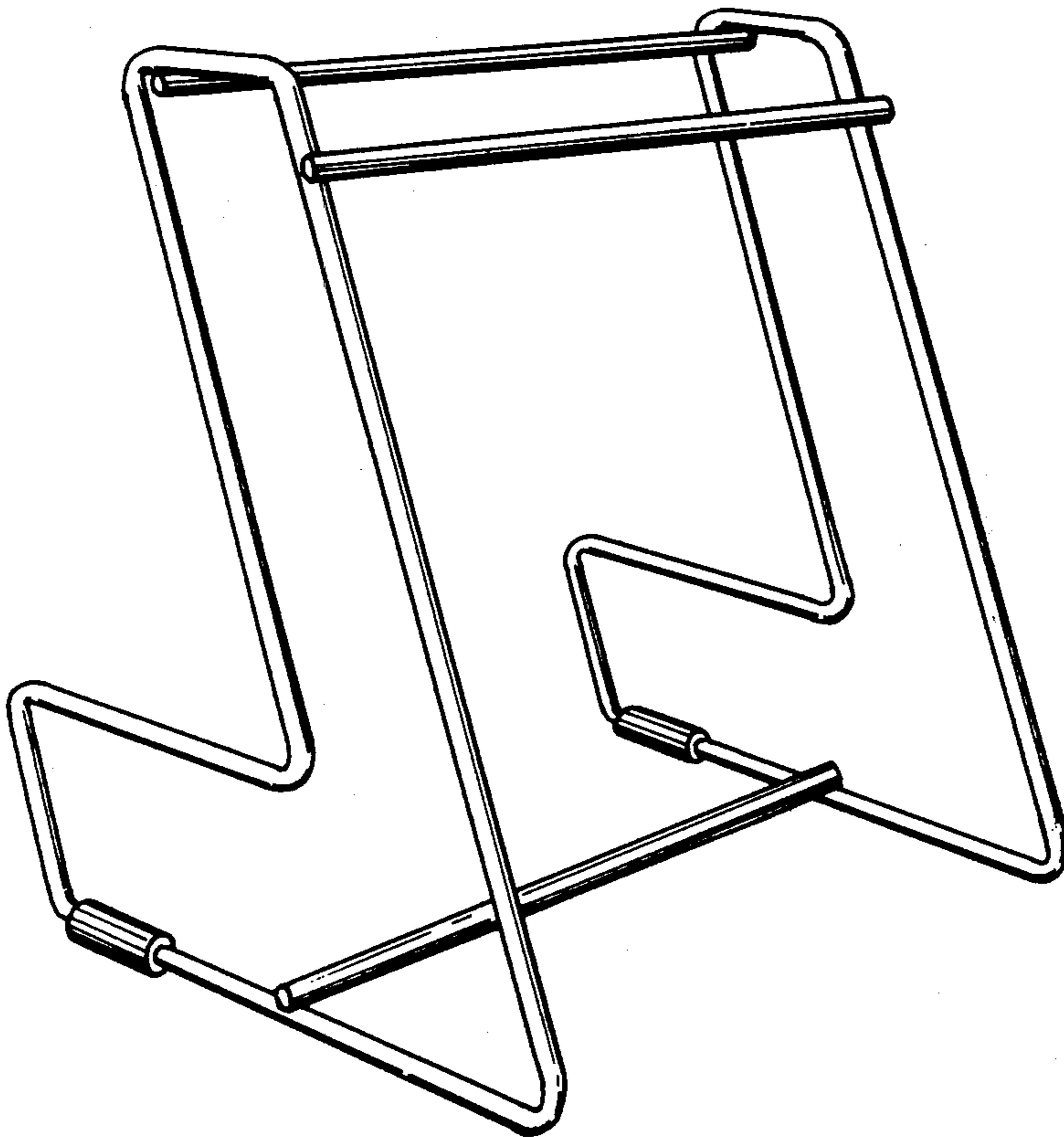

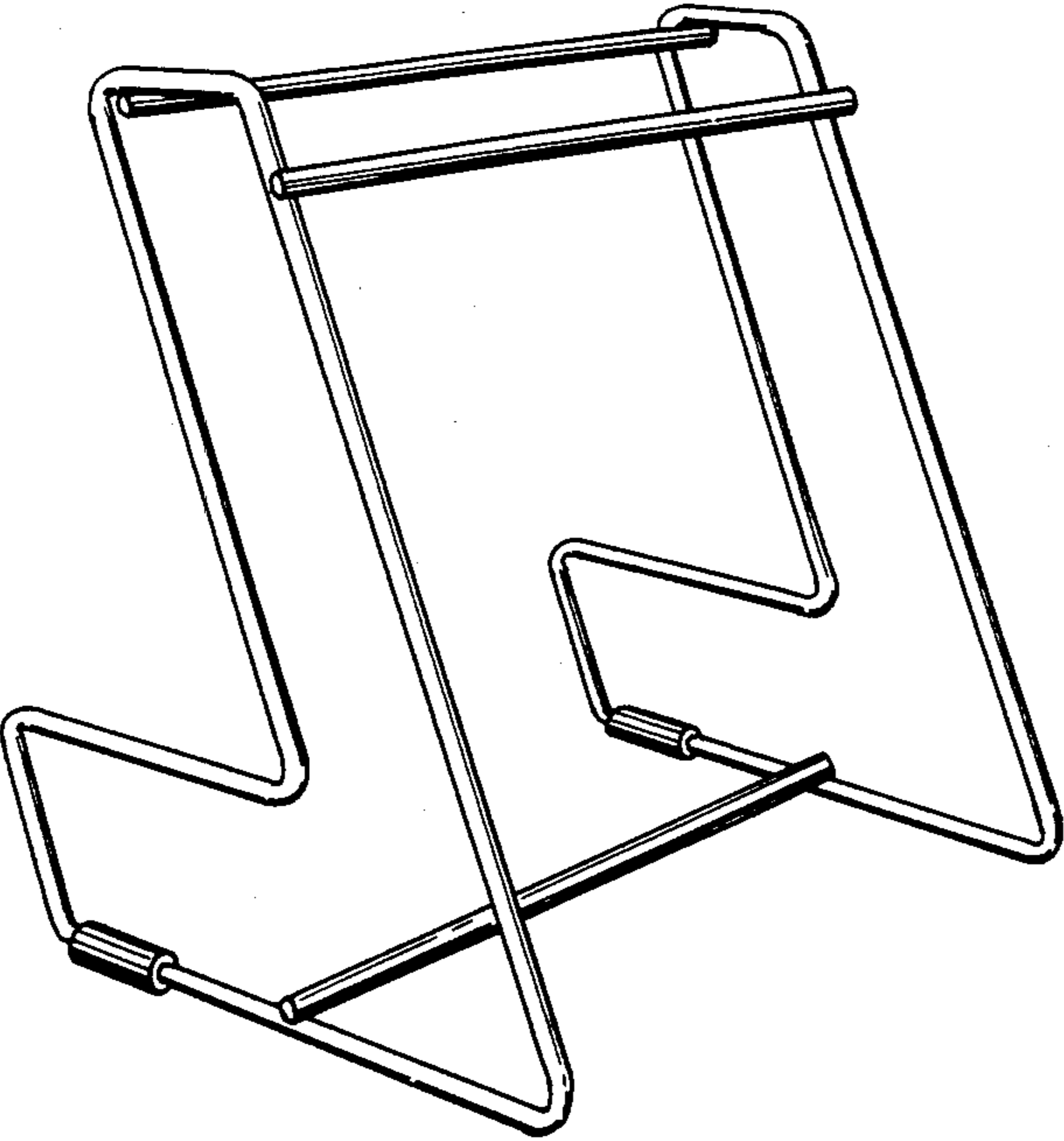

FIG. 1

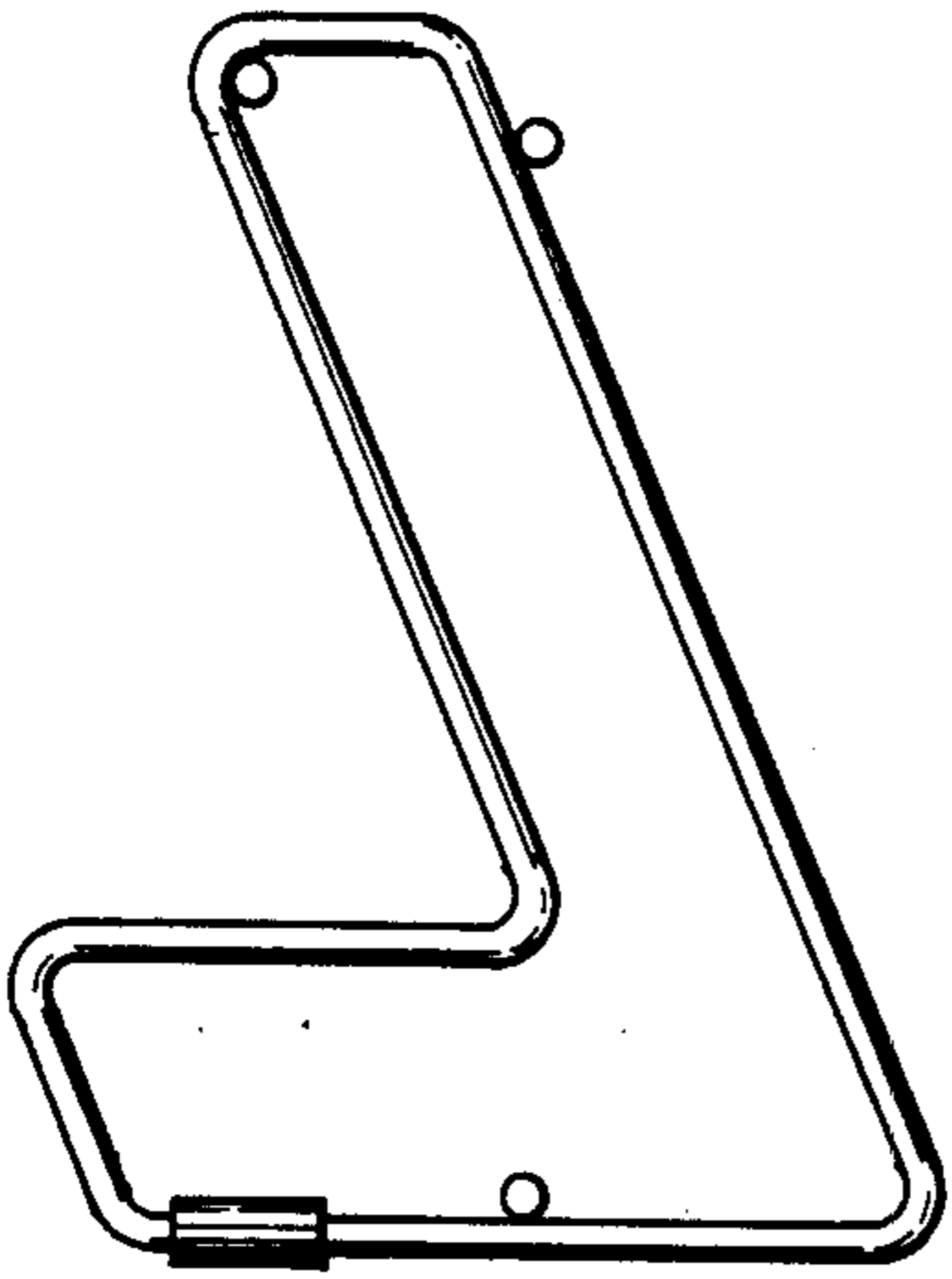

FIG. 2

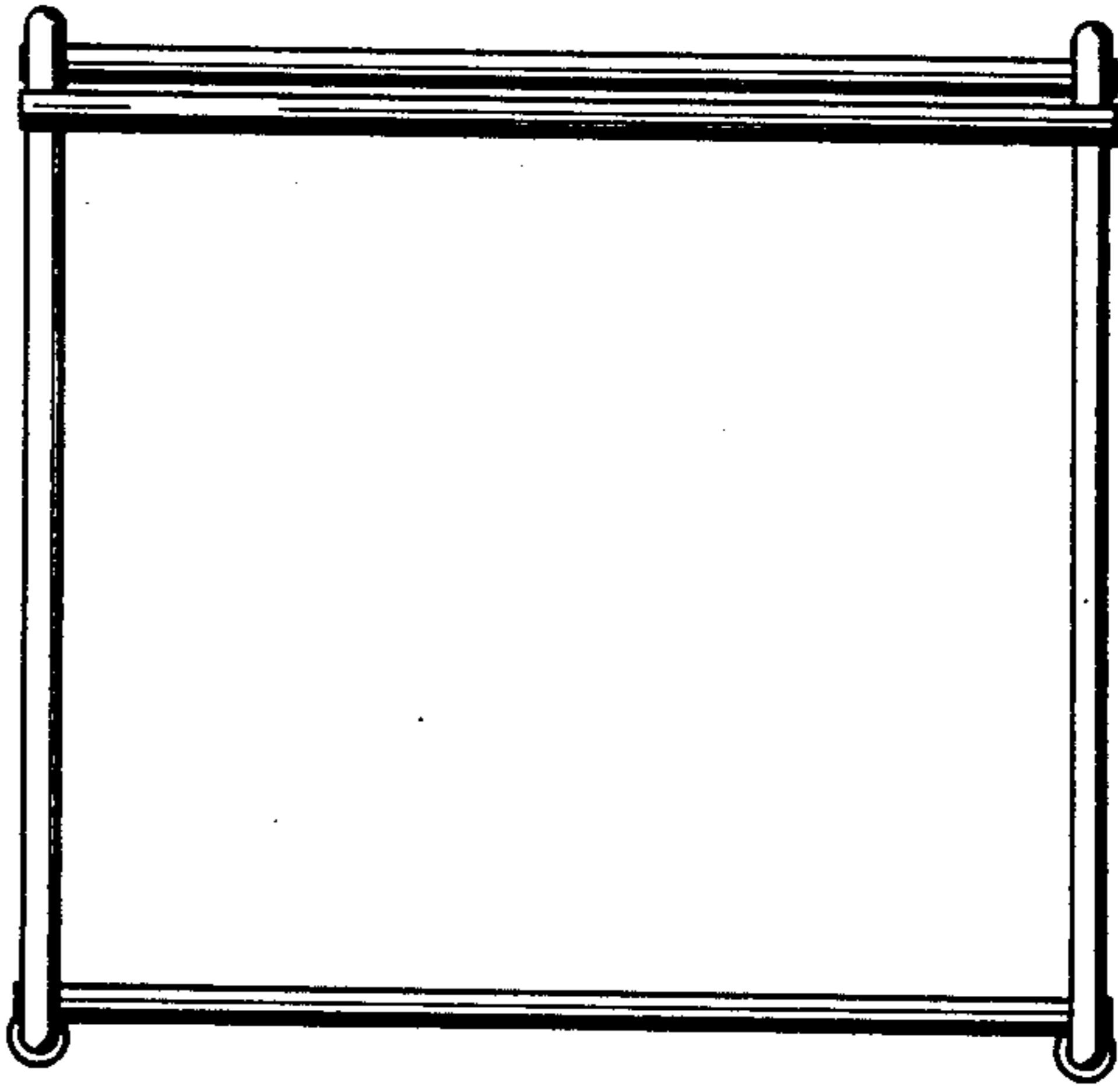

FIG. 3

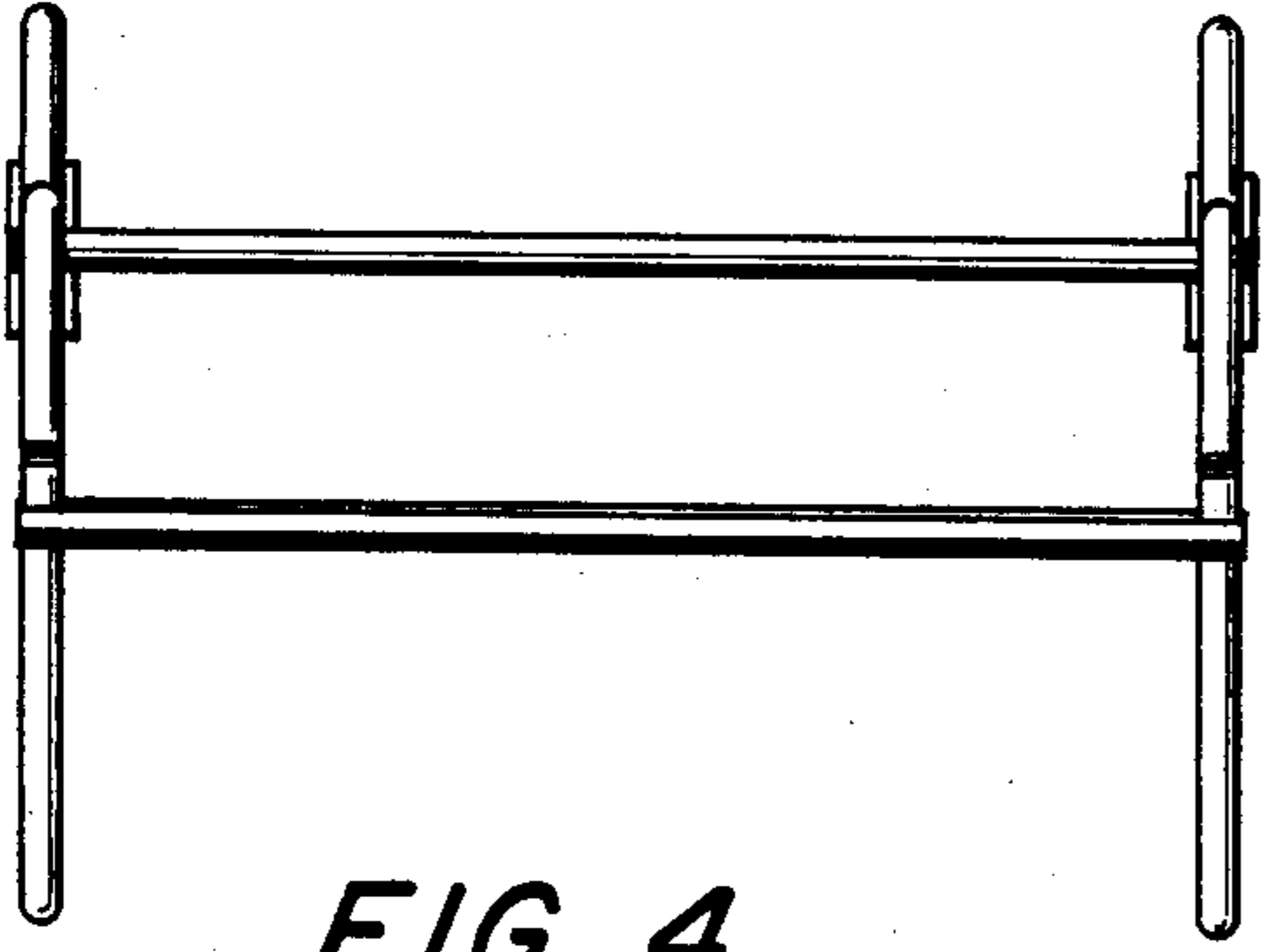

FIG. 4

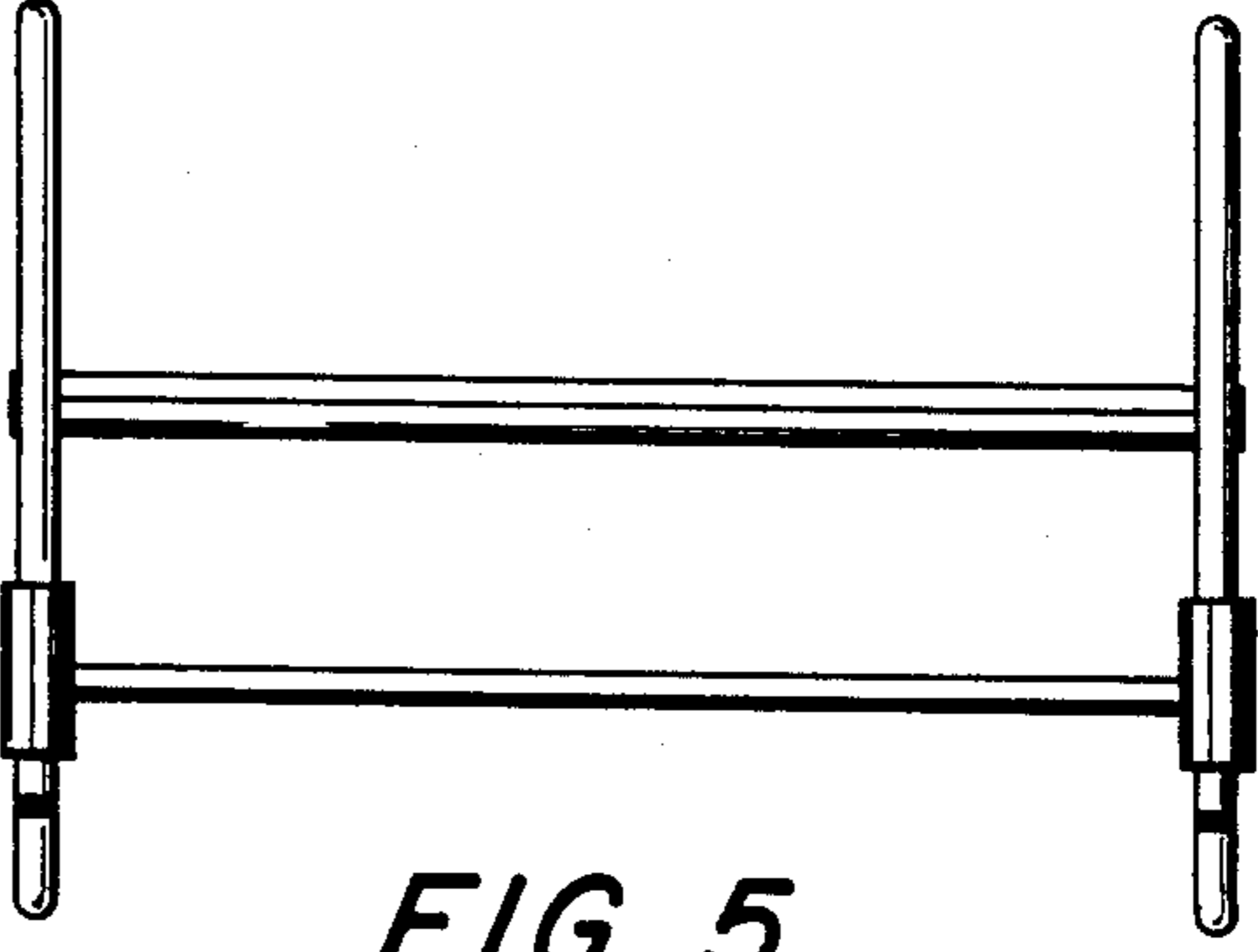

FIG. 5