

[54] TOY VEHICLE

[75] Inventor: Shinroku Nakao, Yokohama, Japan

[73] Assignee: Combi Co., Ltd., Tokyo, Japan

[**] Term: 14 Years

[21] Appl. No.: 646,103

[22] Filed: Jan. 2, 1976

[51] Int. Cl. D21-01

[52] U.S. Cl. D34/15 AJ

[58] Field of Search D34/15 AJ, 15 AM, 15 AN, D34/15 D; 46/103, 105, 201, 202, 204, 206, 210, 211, 212, 213; 280/87.01, 87.02 R

[56] References Cited

U.S. PATENT DOCUMENTS

2,186,188 1/1940 Allen 46/201

FOREIGN PATENT DOCUMENTS

2,220,344 11/1973 Germany 280/87.02 R

OTHER PUBLICATIONS

Toys, Mar. 1971,, p. 140, toy vehicle.
Playthings, Mar. 1972, p. 8, Super Bear riding toy.

Primary Examiner—Nelson C. Holtje
Assistant Examiner—C. A. Rademaker
Attorney, Agent, or Firm—Richard C. Sughrue

[57] CLAIM

The ornamental design for a toy vehicle, as shown.

DESCRIPTION

FIG. 1 is a front, top and left side perspective view of a toy vehicle showing my new design;
FIG. 2 is a rear, bottom and right side perspective view;
FIG. 3 is a top plan view; and
FIG. 4 is a bottom plan view thereof.

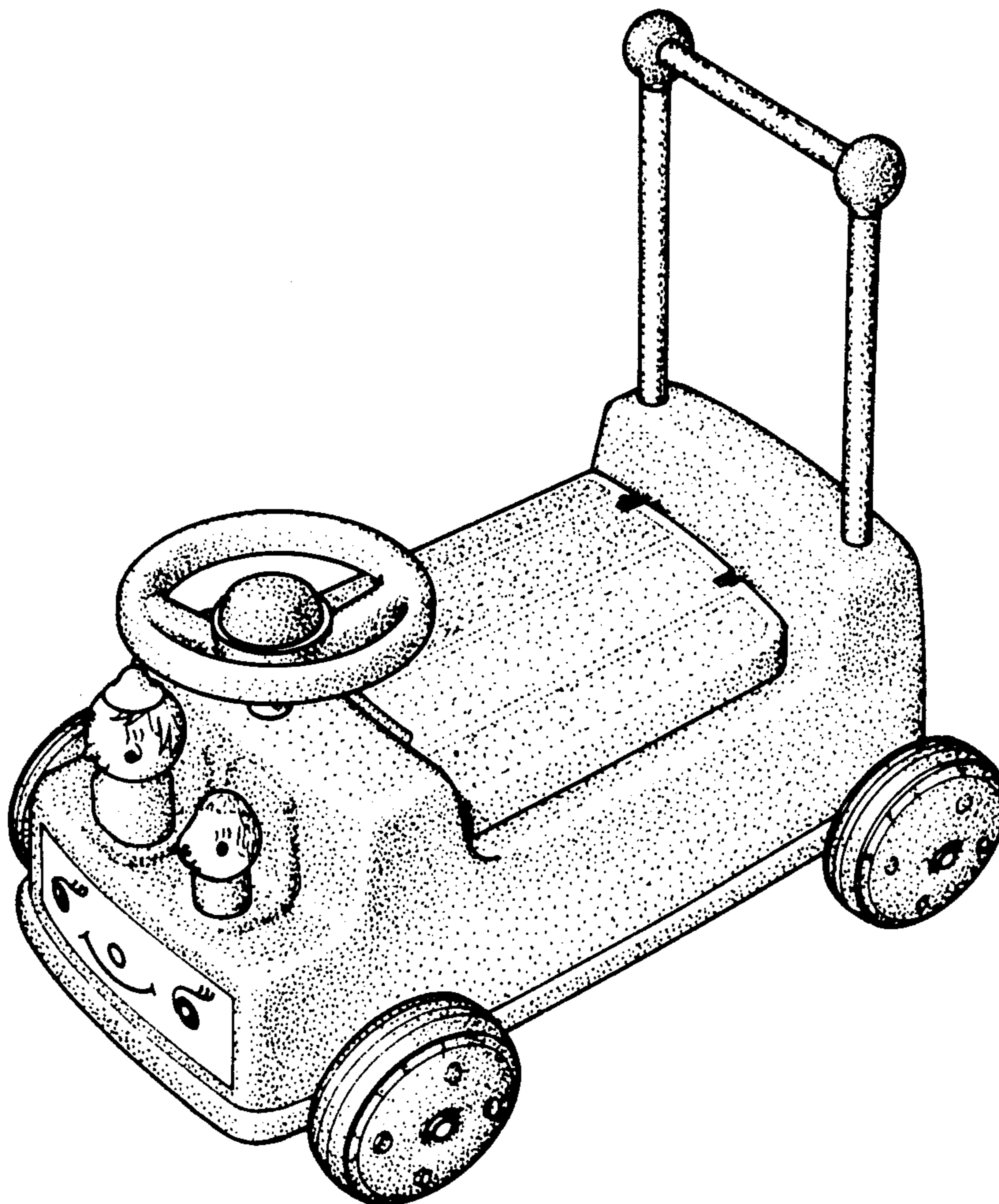

FIG. 1

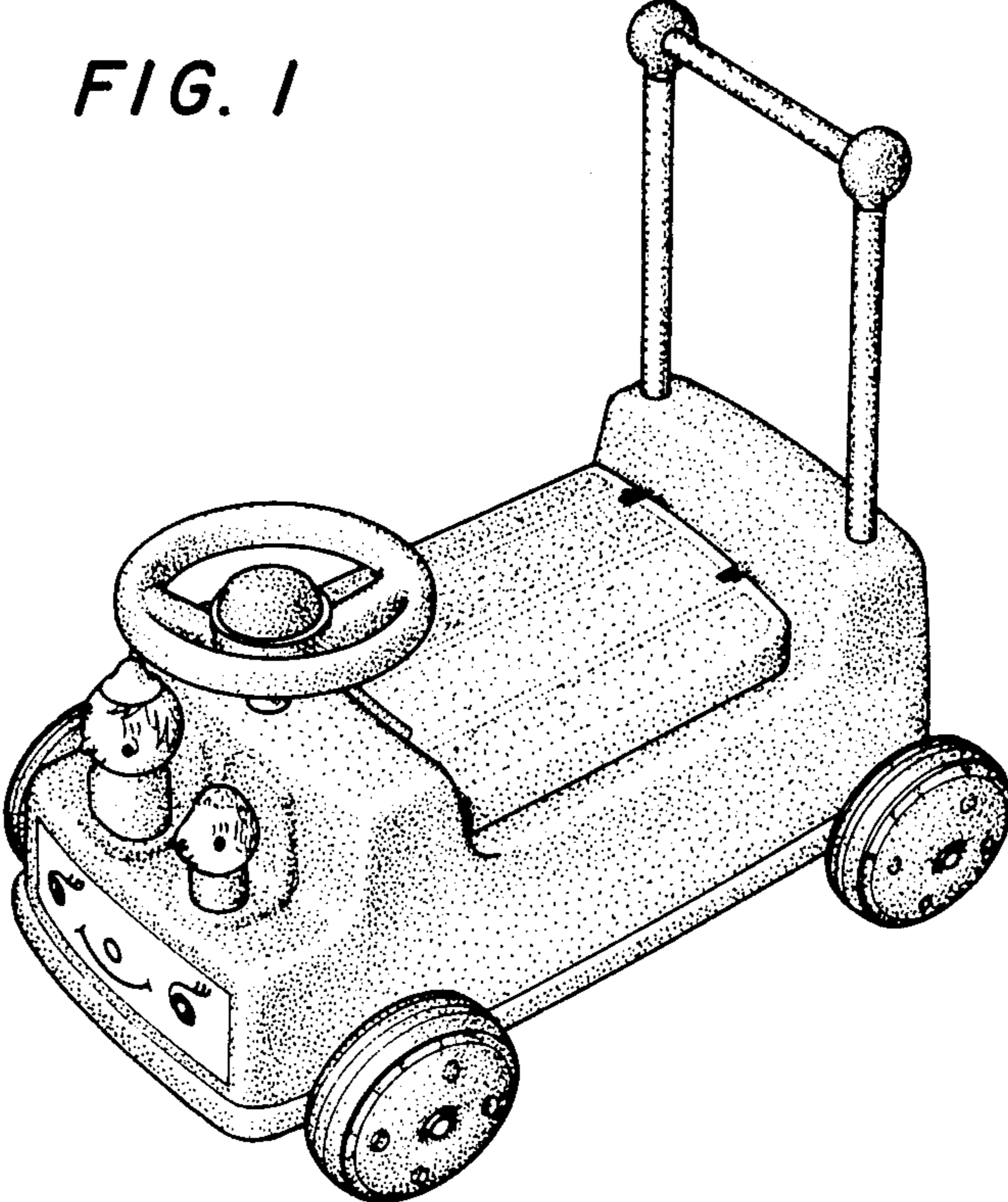

FIG. 2

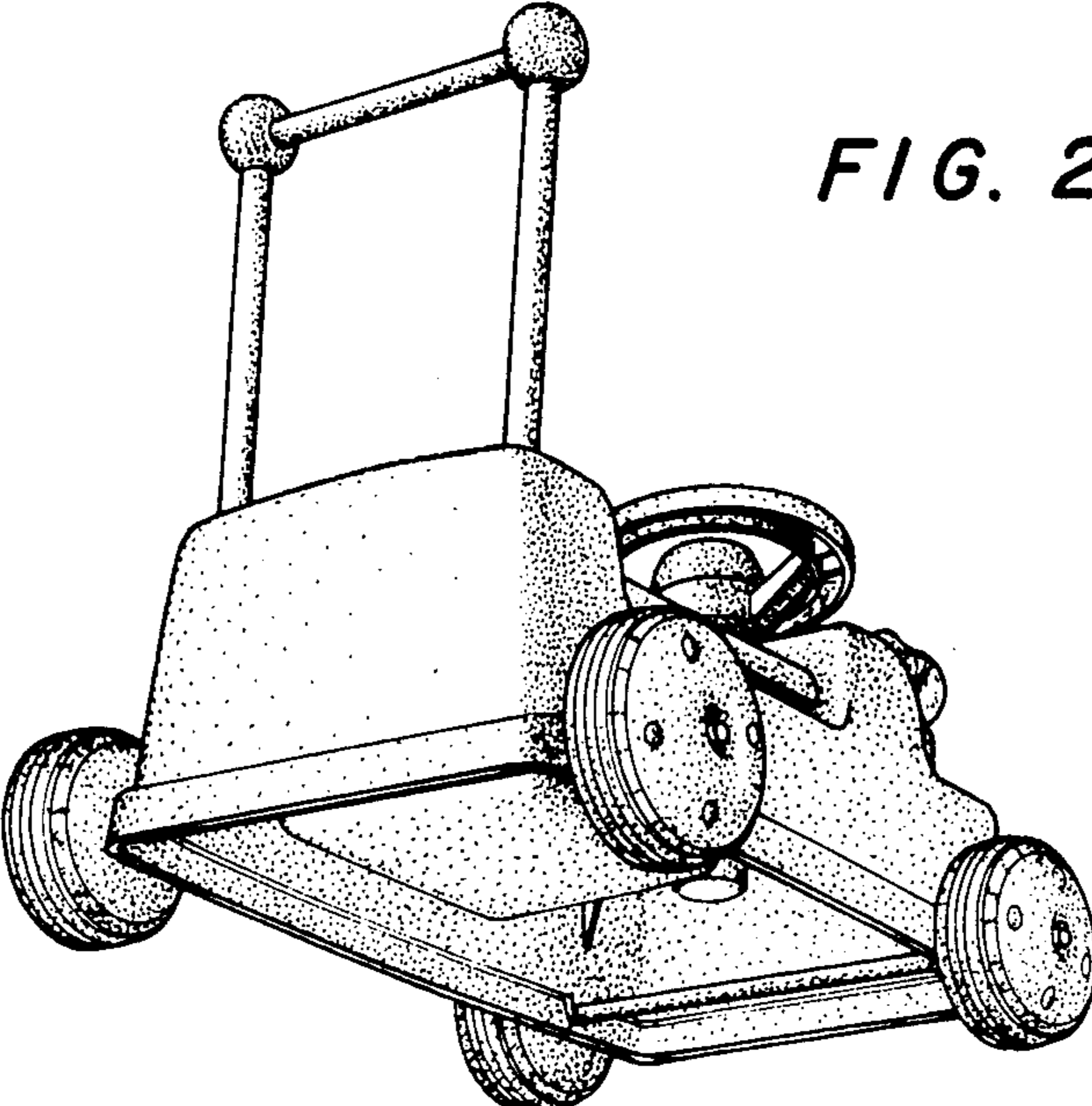

FIG. 3

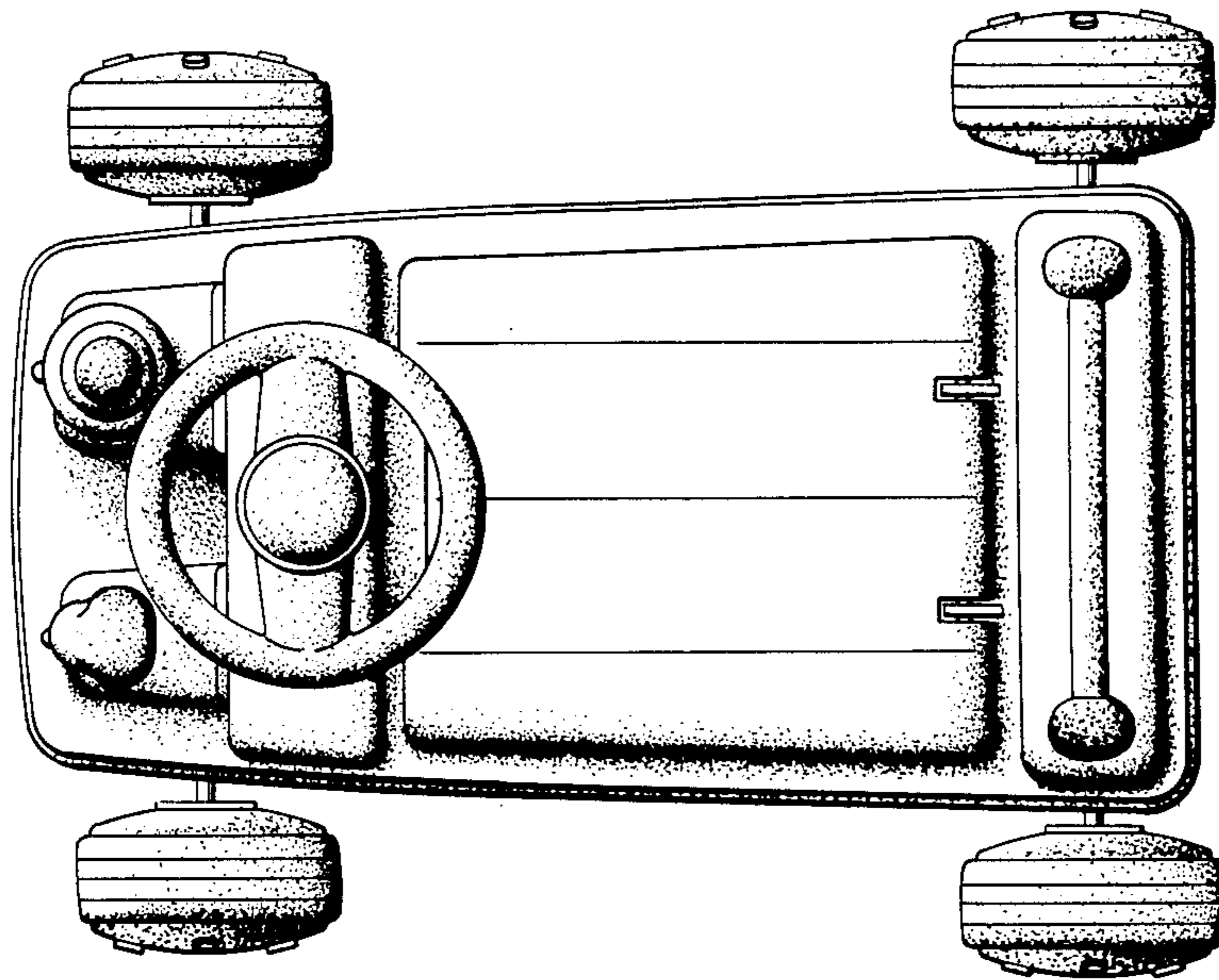

FIG. 4

