

[54] TRAILER

[75] Inventors: Charles W. Dortch, Houston; Donald K. Vaught, Victoria, both of Tex.

[73] Assignee: George C. Ballas, Sr., Houston, Tex.

[**] Term: 14 Years

[21] Appl. No.: 697,676

[22] Filed: June 18, 1976

[51] Int. Cl. D12-10

[52] U.S. Cl. D12/105

[58] Field of Search D12/24, 32, 101, 105, D12/114; 280/204, 47.11, 63

[56]

References Cited

U.S. PATENT DOCUMENTS

2,468,894 5/1949 Peek D12/114

FOREIGN PATENT DOCUMENTS

808,416 7/1951 Germany 280/204

OTHER PUBLICATIONS

American Bicyclist & Motorcyclist, Feb. 1976, p. 28, Bicycle Trailer, top right side of page.
Horticulture, 7/73, p. 9, Jumbo Cart, bottom center of page.

Primary Examiner—Wallace R. Burke
Assistant Examiner—James M. Gandy
Attorney, Agent, or Firm—Edmund F. Bard

[57] CLAIM

The ornamental design for a trailer, substantially as shown.

DESCRIPTION

FIG. 1 is a side elevational view of a trailer embodying a new design;
FIG. 2 is a front elevational view;
FIG. 3 is a rear elevational view;
FIG. 4 is a top plan view; and
FIG. 5 is a bottom plan view thereof.

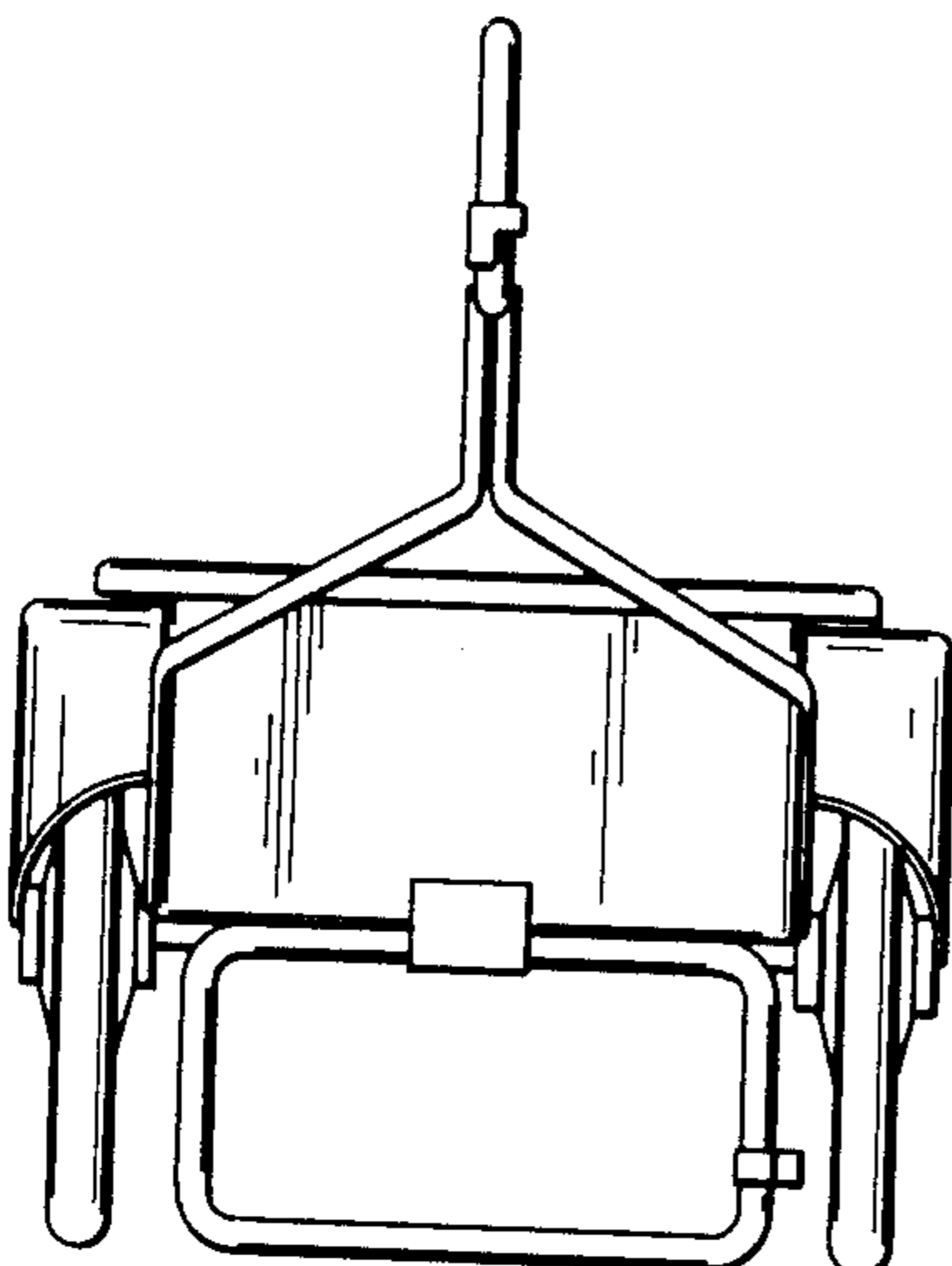
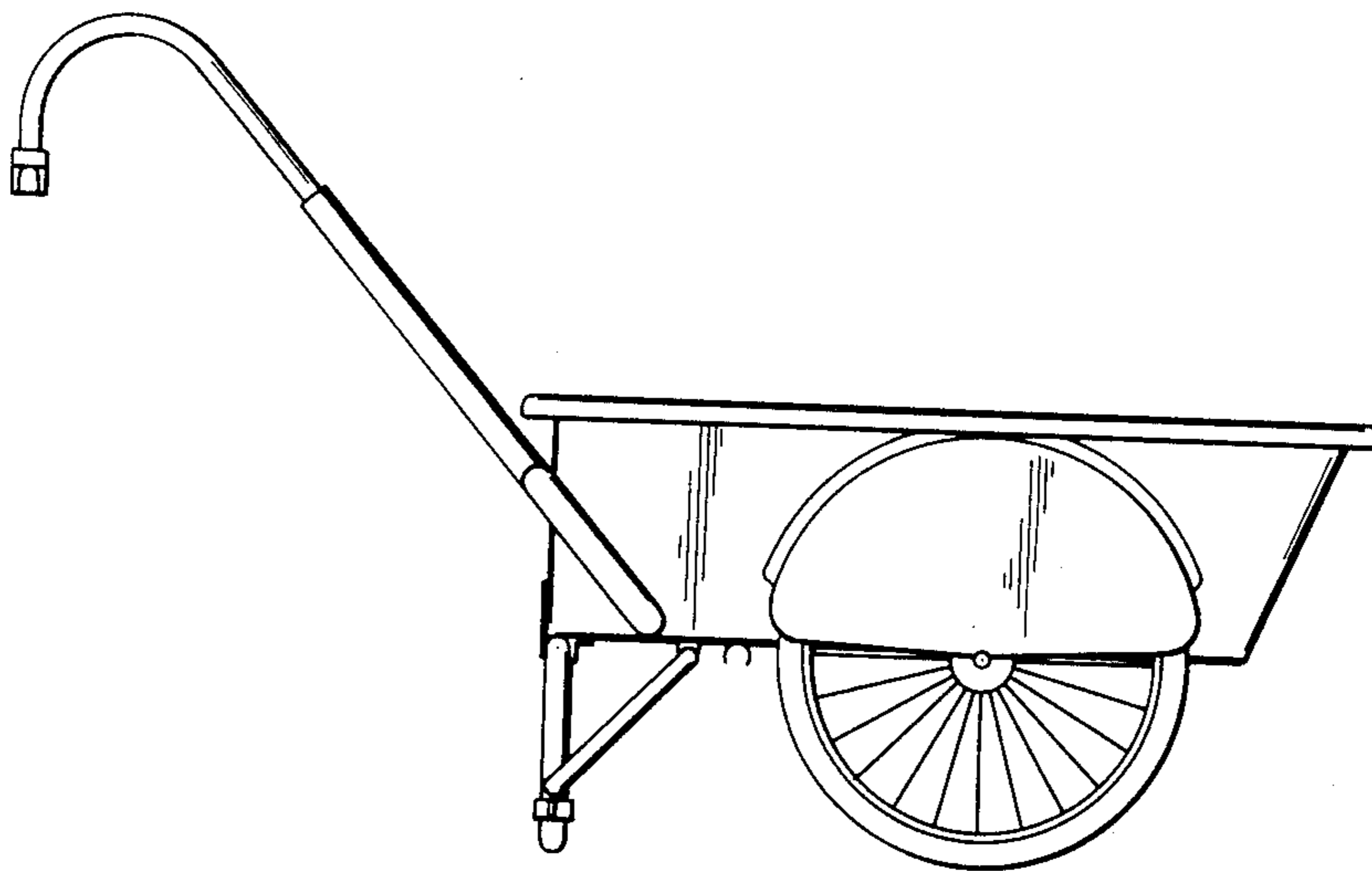

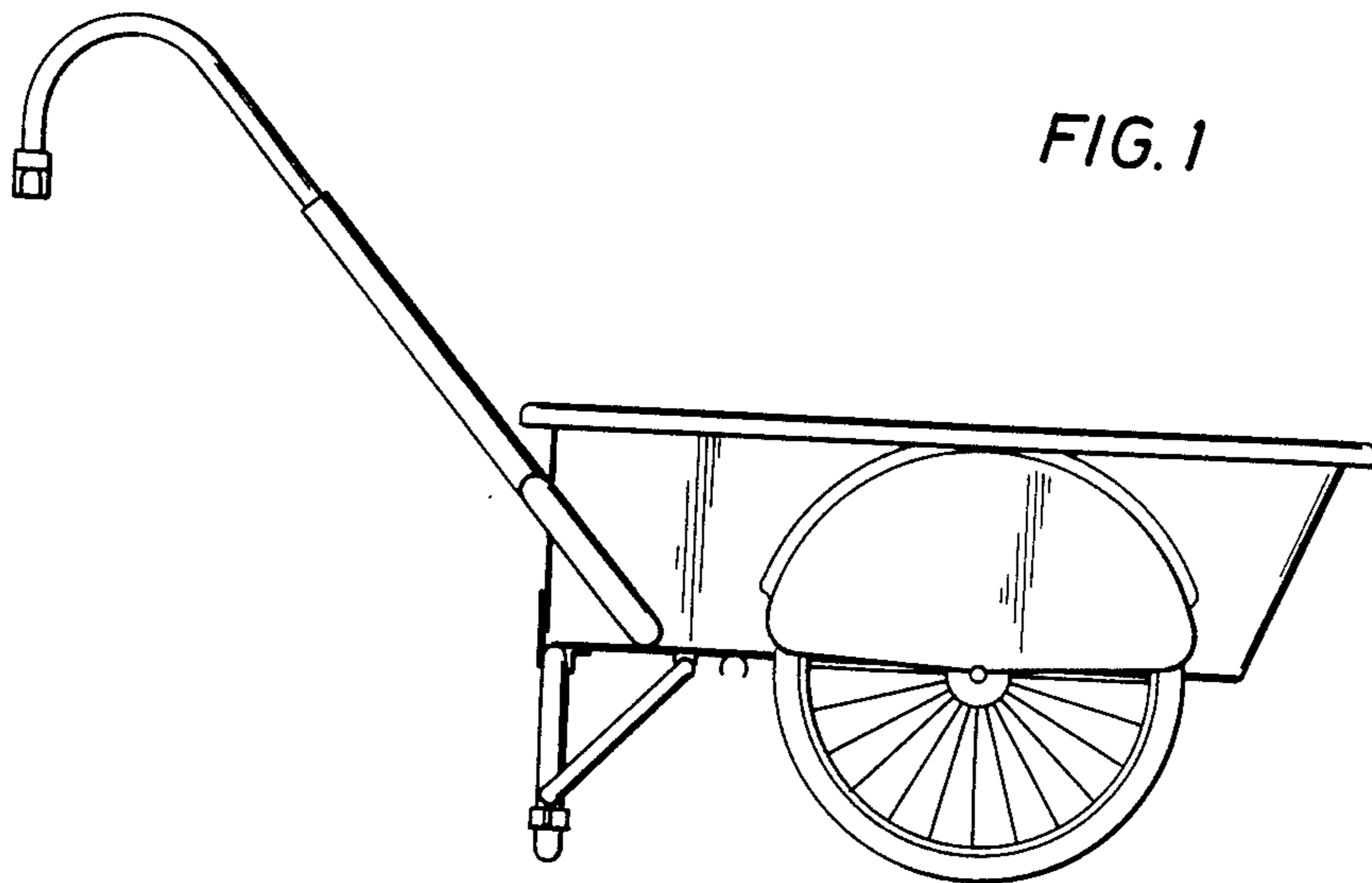

FIG. 1

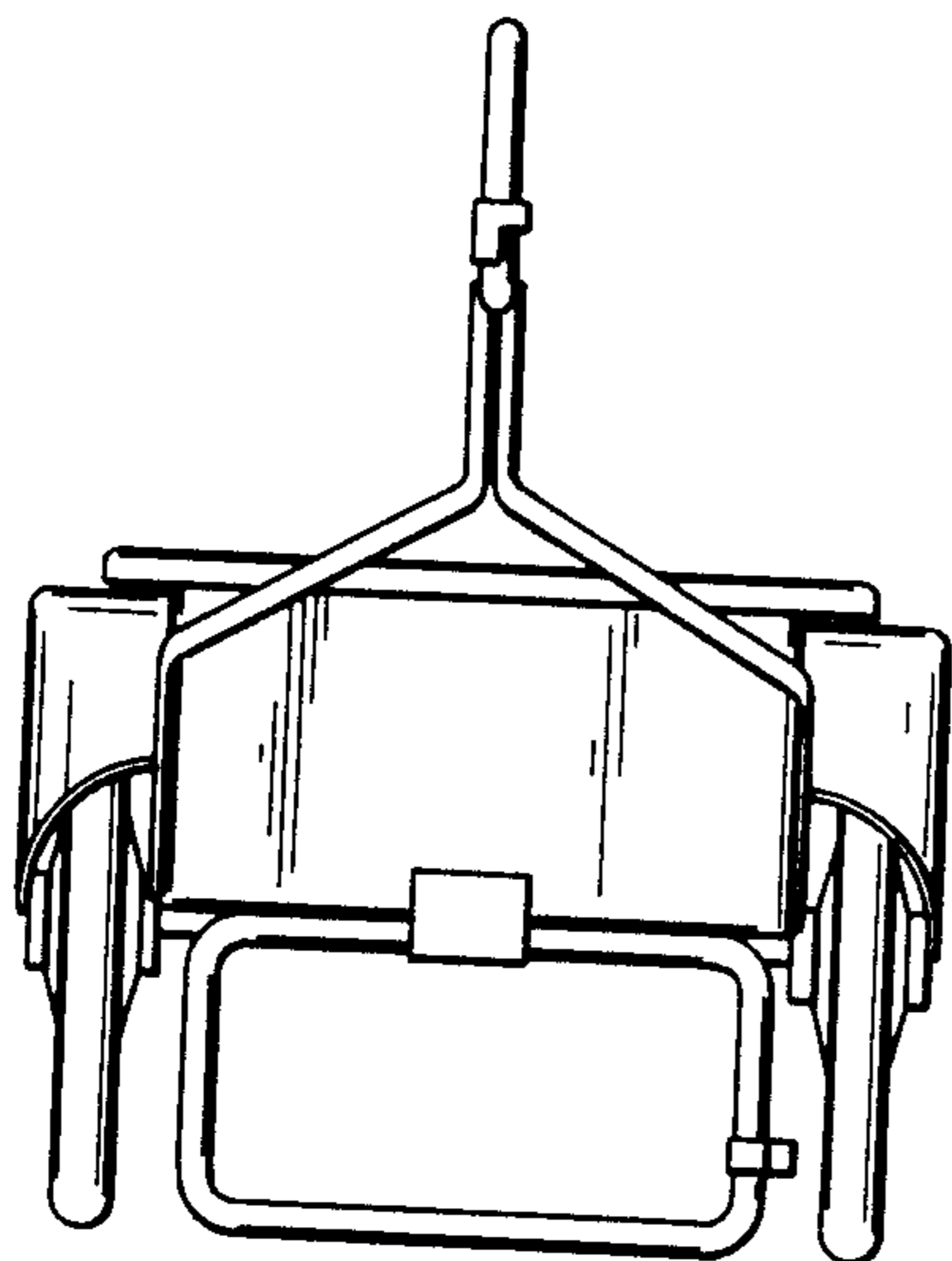

FIG. 2

FIG. 3

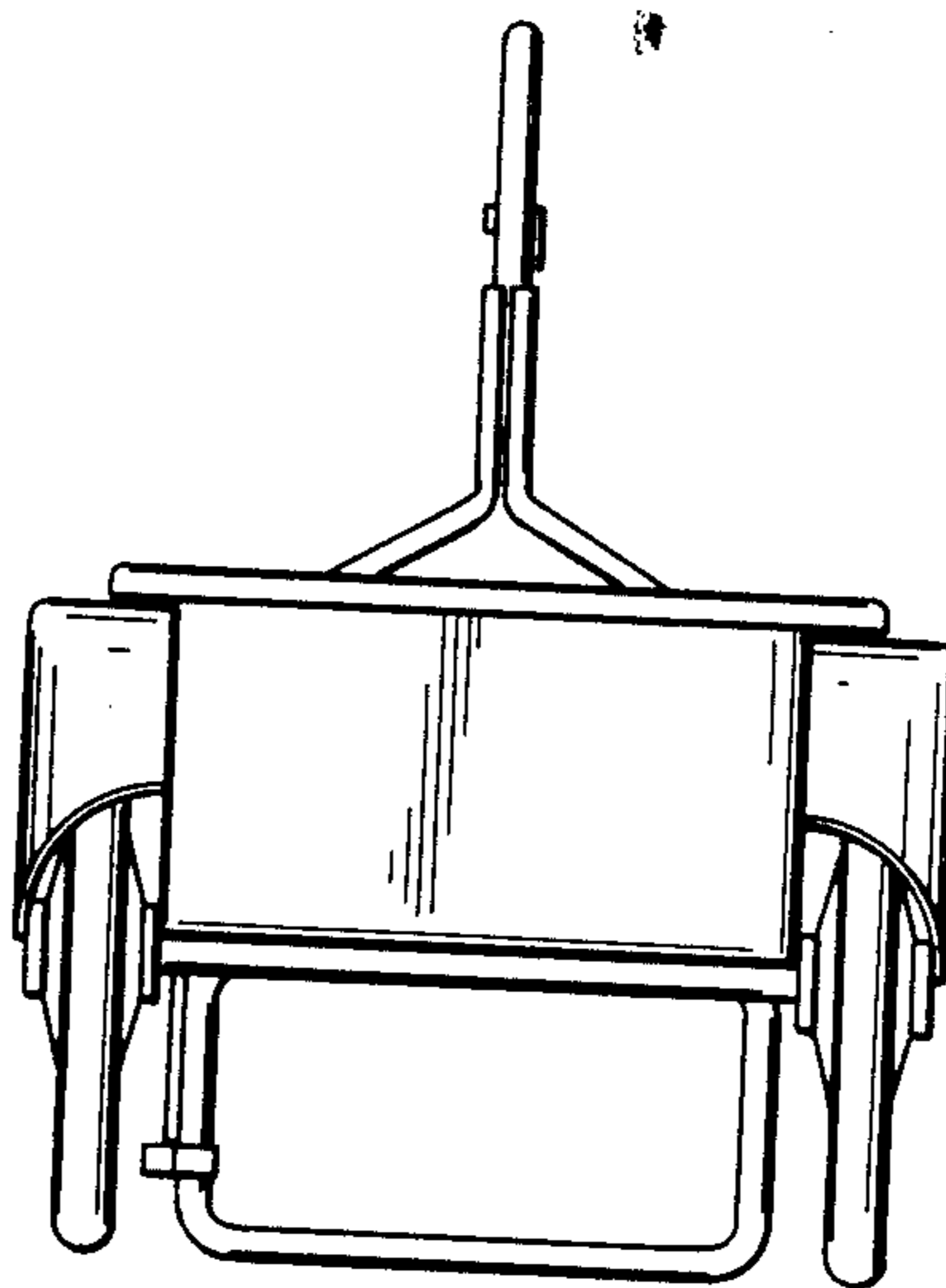

FIG. 4

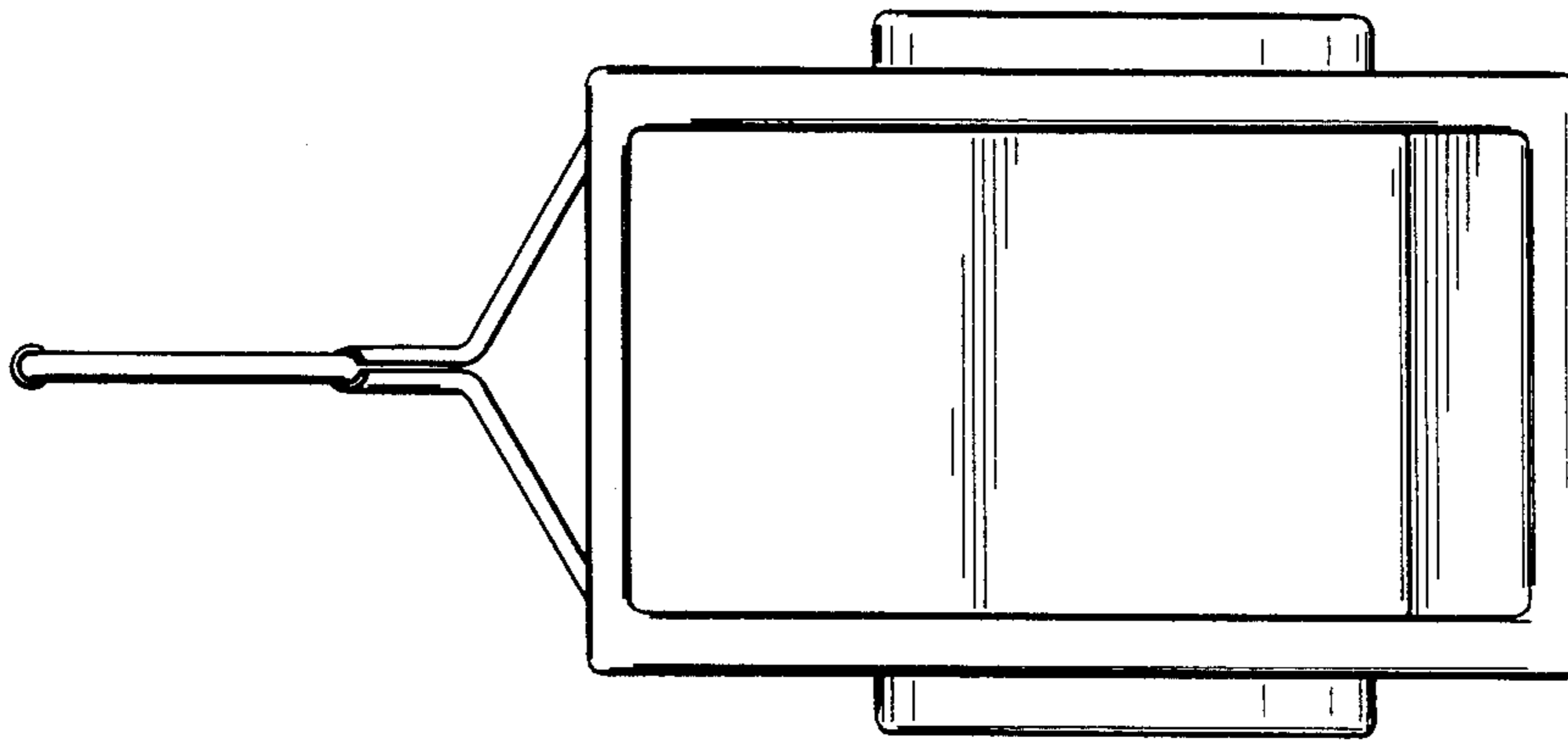

FIG. 5

