

[54] **AMPHIBIOUS AIRPLANE**

[76] **Inventor:** Carl I. Hansen, Box 106, Melvin Village, N.H. 03850

[**] **Term:** 7 Years

[21] **Appl. No.:** 720,264

[22] **Filed:** Sept. 3, 1976

[51] **Int. Cl.** **D12-14**
[52] **U.S. Cl.** **D12/75**
[58] **Field of Search** **D12/75, 78; 244/36, 244/105, 106**

[56]

References Cited

U.S. PATENT DOCUMENTS

| | | | |
|------------|--------|---------------|-----------|
| D. 137,891 | 5/1944 | Kelly | 244/36 X |
| 1,928,317 | 9/1933 | Rippen | 244/105 X |
| 3,869,102 | 3/1975 | Carroll | 244/36 |

Primary Examiner—Alan P. Douglas
Attorney, Agent, or Firm—Abbott Spear

[57]

CLAIM

The ornamental design for an amphibious airplane, as shown.

DESCRIPTION

FIG. 1 is a front perspective view of an Amphibious Airplane showing my new design; FIG. 2 is a side view thereof; FIG. 3 is a front elevation thereof; FIG. 4 is a rear elevation thereof; and FIG. 5 is a bottom plan view of the airplane.

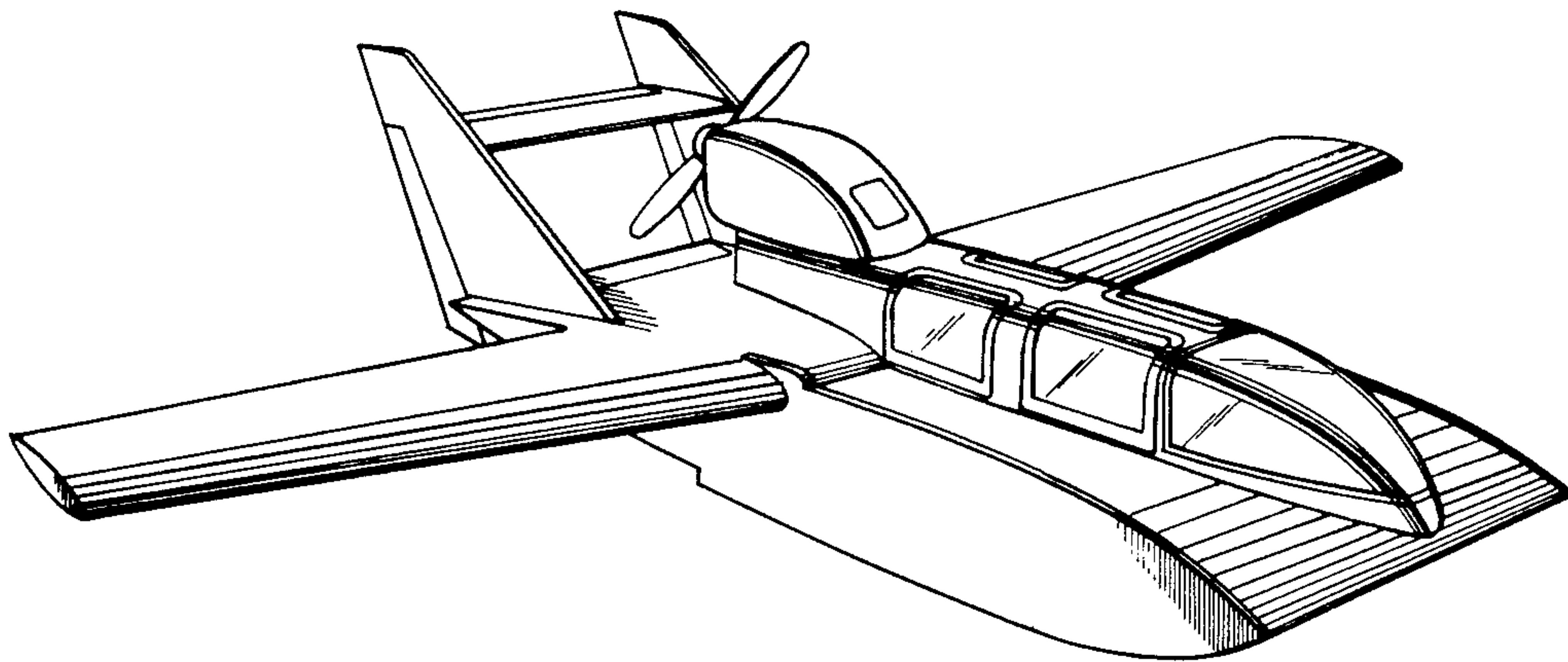

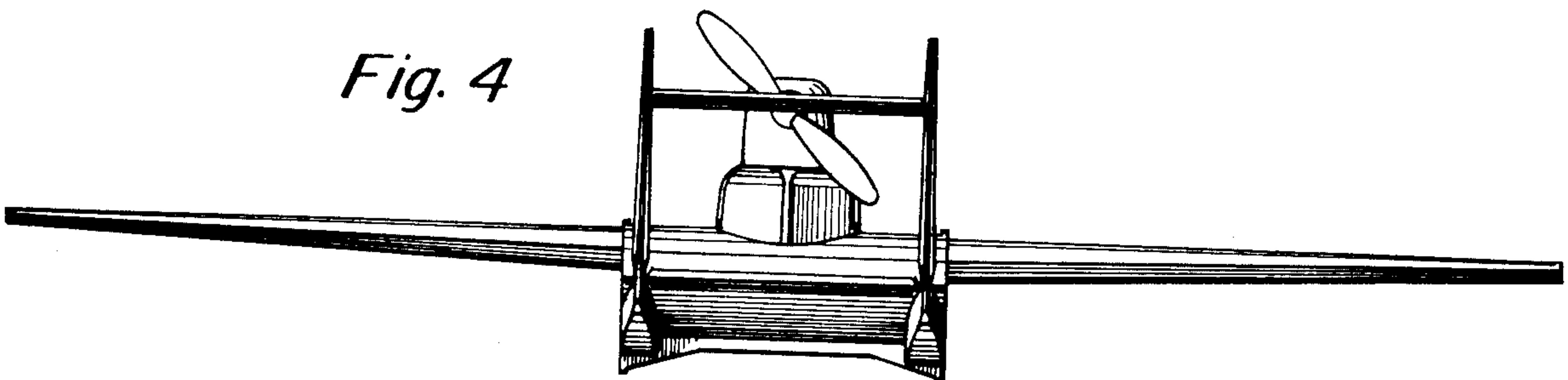
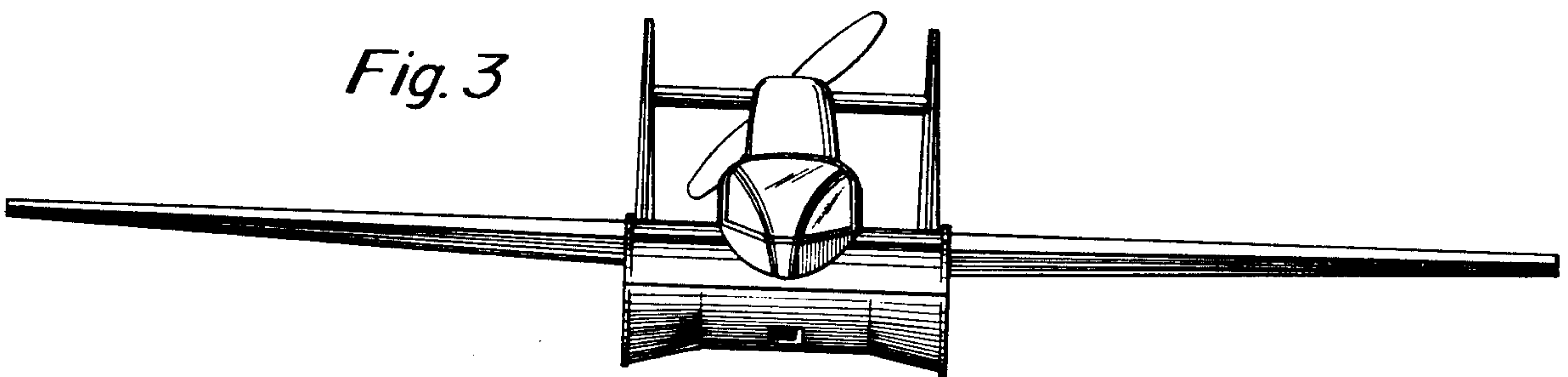
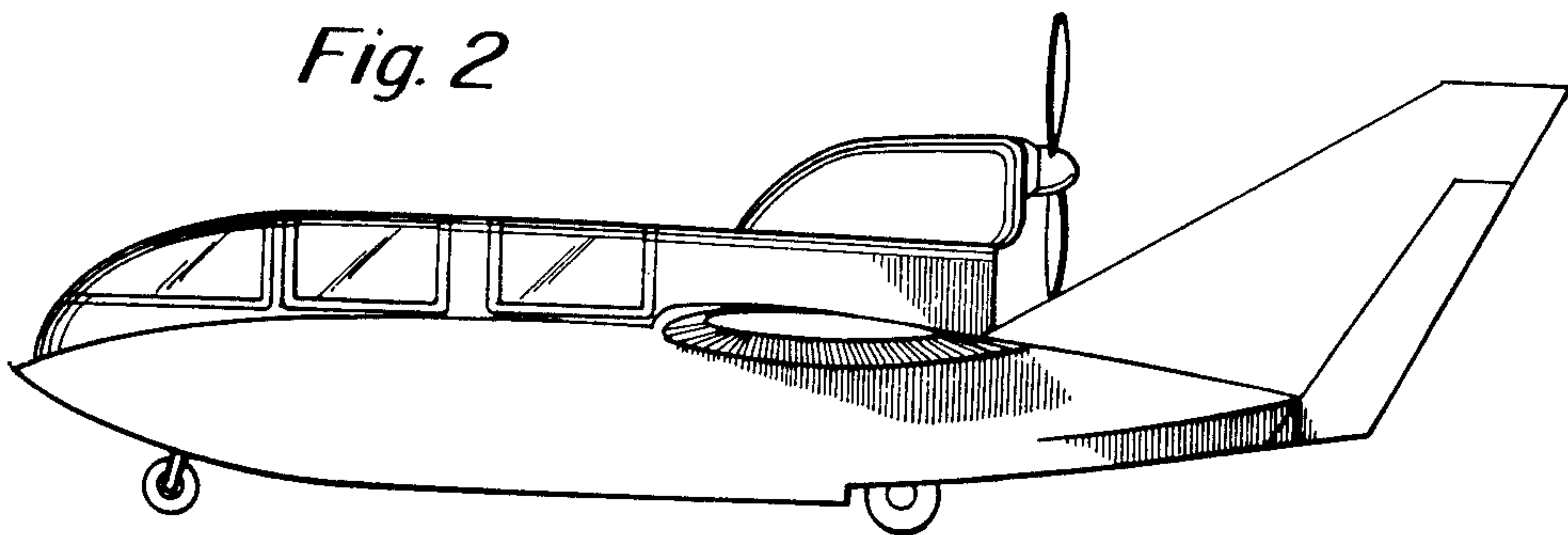
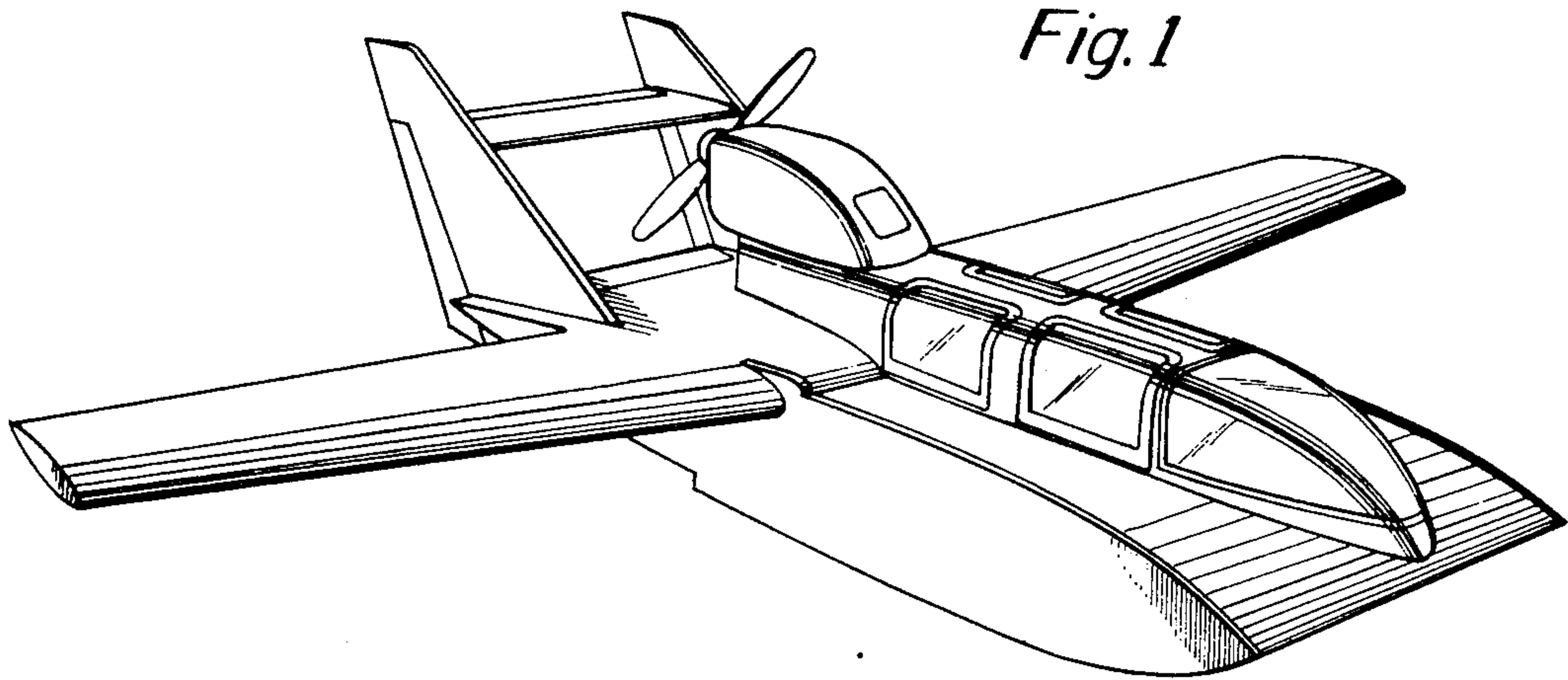

Fig. 5

