

[54] BOOK BINDING MACHINE

[75] Inventors: James G. Balmer, Bloomfield Hills; Peter E. Linder, Southfield, both of Mich.

[73] Assignee: Velo-Bind, Inc., Sunnyvale, Calif.

[\*\*] Term: 14 Years

[21] Appl. No.: 626,287

[22] Filed: Oct. 28, 1975

[51] Int. Cl. .... D18-04

[52] U.S. Cl. .... D64/11 R

[58] Field of Search ..... D19/72; D64/11 R; D15/145-146; 270/53, 58; 281/21 R, 21 A; 83/590; 11/1 R-11 AC; D8/47

[56] References Cited

U.S. PATENT DOCUMENTS

3,060,780	10/1962	Stuckens .....	11/1 AC
3,879,785	4/1975	Giulie .....	11/1 MB
3,967,336	7/1976	Cutter .....	11/1 AC

Primary Examiner—Joel Stearman  
Assistant Examiner—George P. Word  
Attorney, Agent, or Firm—Julian Caplan

[57] CLAIM

The ornamental design for a book binding machine, as shown and described.

DESCRIPTION

FIG. 1 is a top plan view of a book binding machine showing our new design.

FIG. 2 is a front elevational view thereof.

FIG. 3 is a side elevational view from the right of FIG. 2; the opposite side is similar.

FIG. 4 is a rear elevational view thereof.

FIG. 5 is a fragmentary cross-sectional view taken substantially along the line 5-5 of FIG. 1.

FIG. 6 is a bottom plan view.

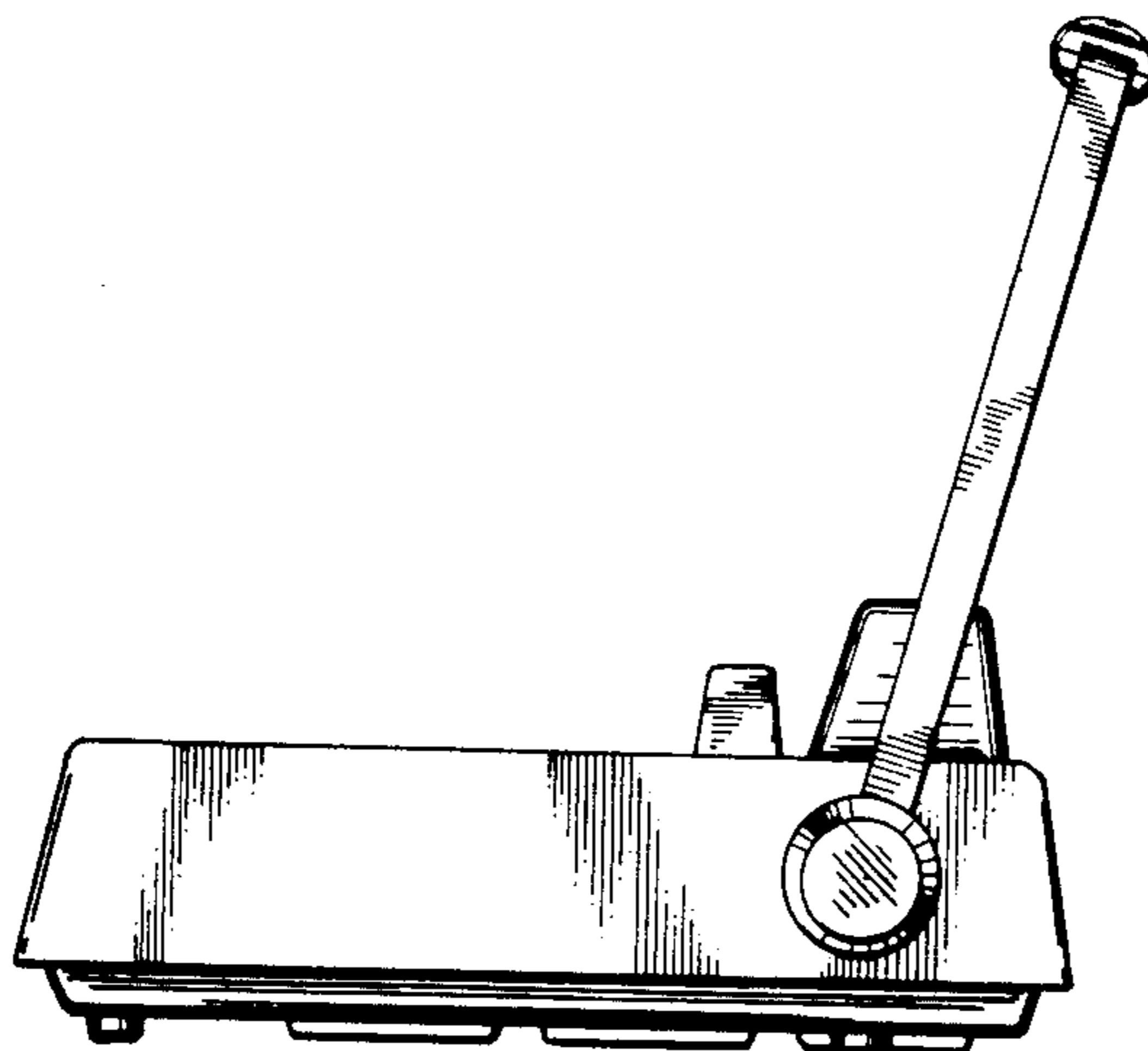
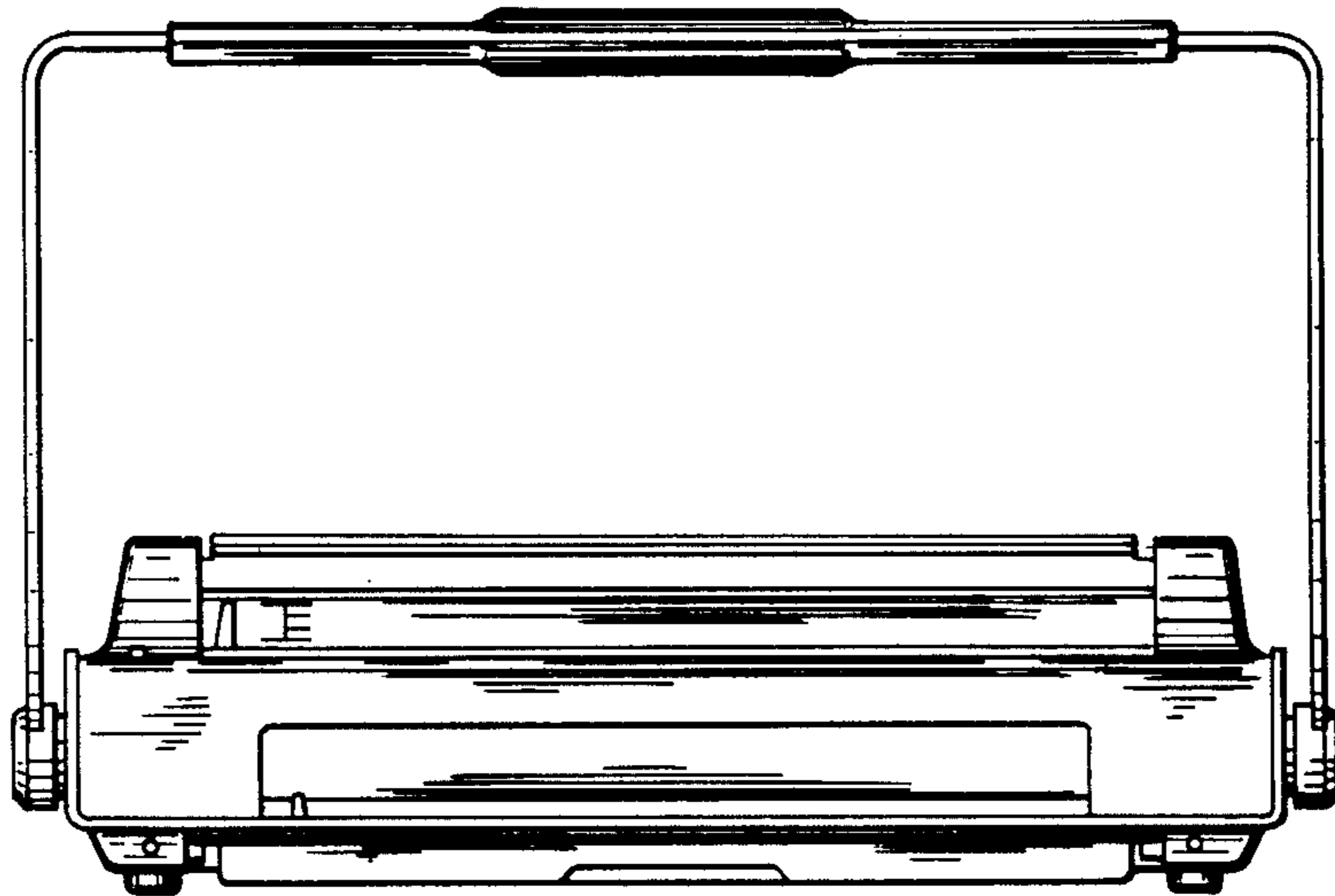

*Fig. 1*

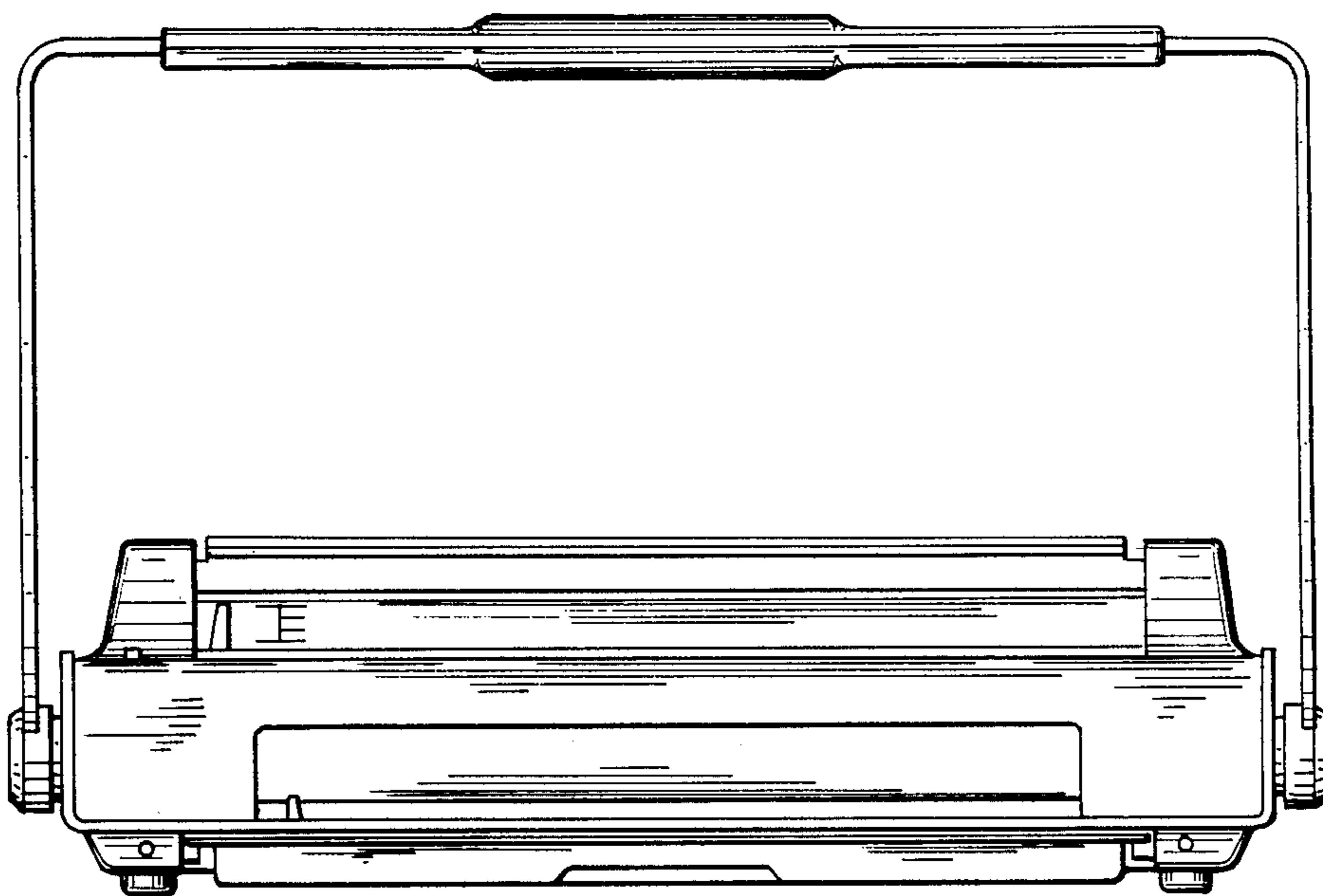
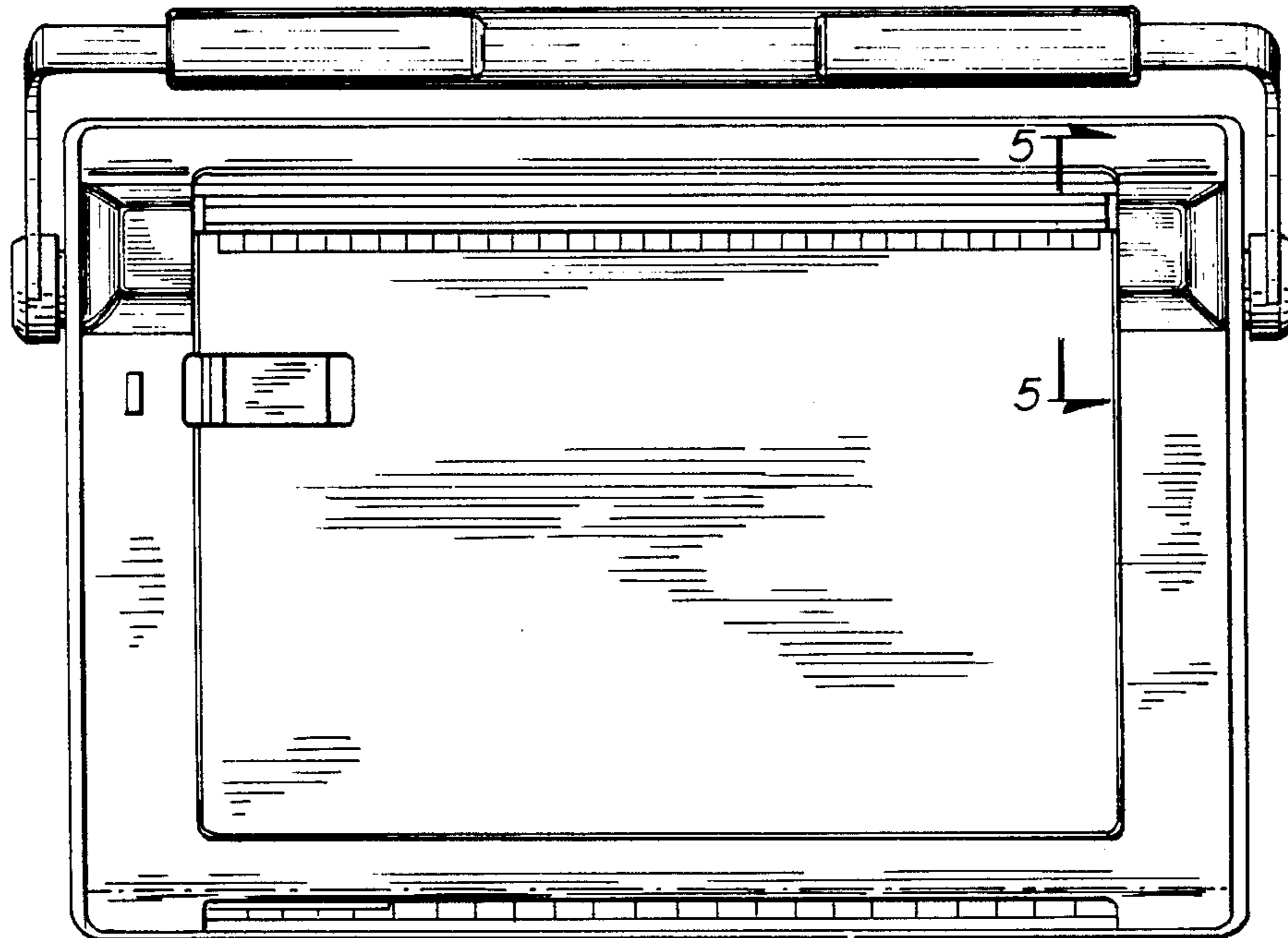

*Fig. 2*

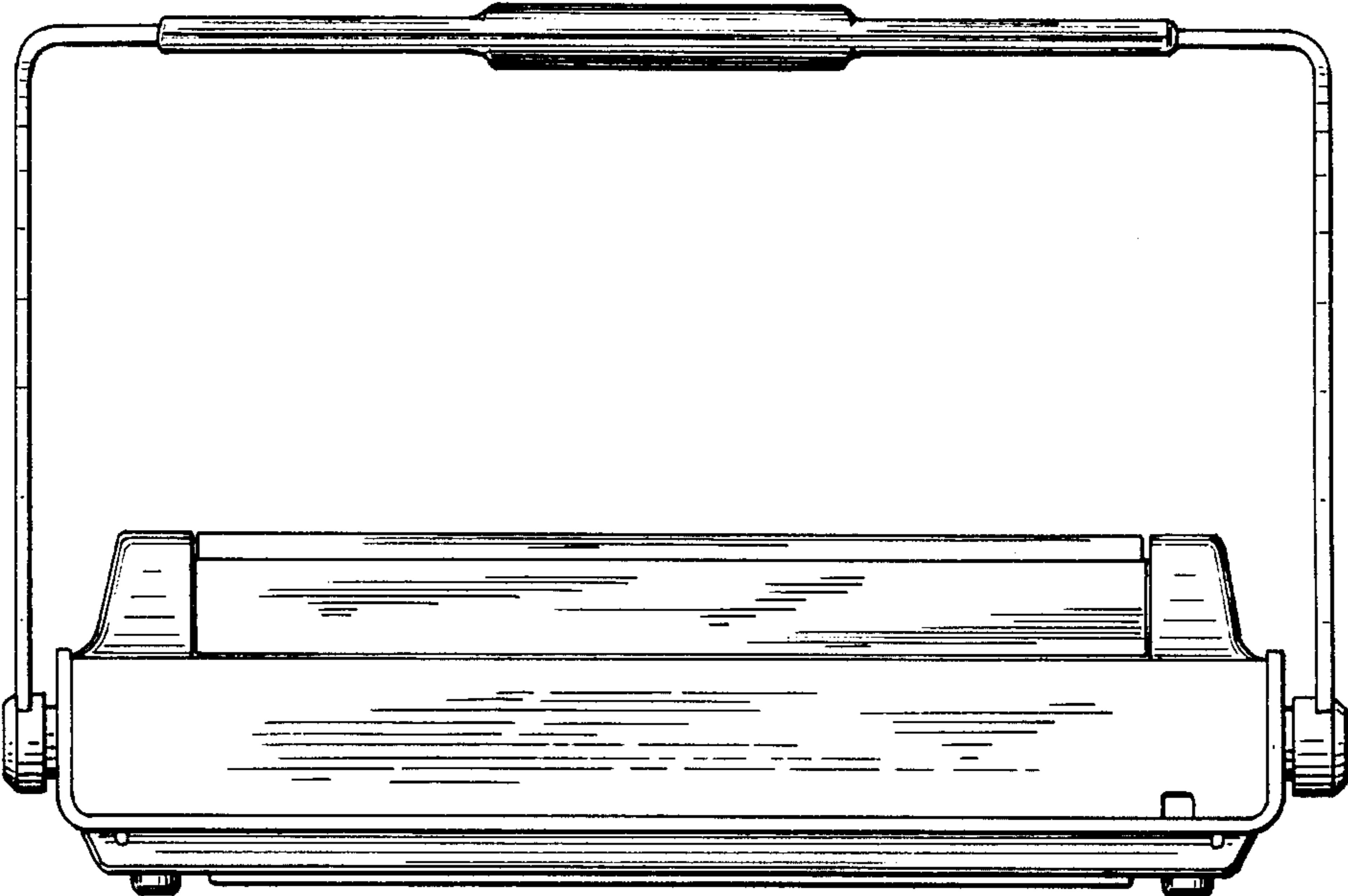

*Fig. 4*

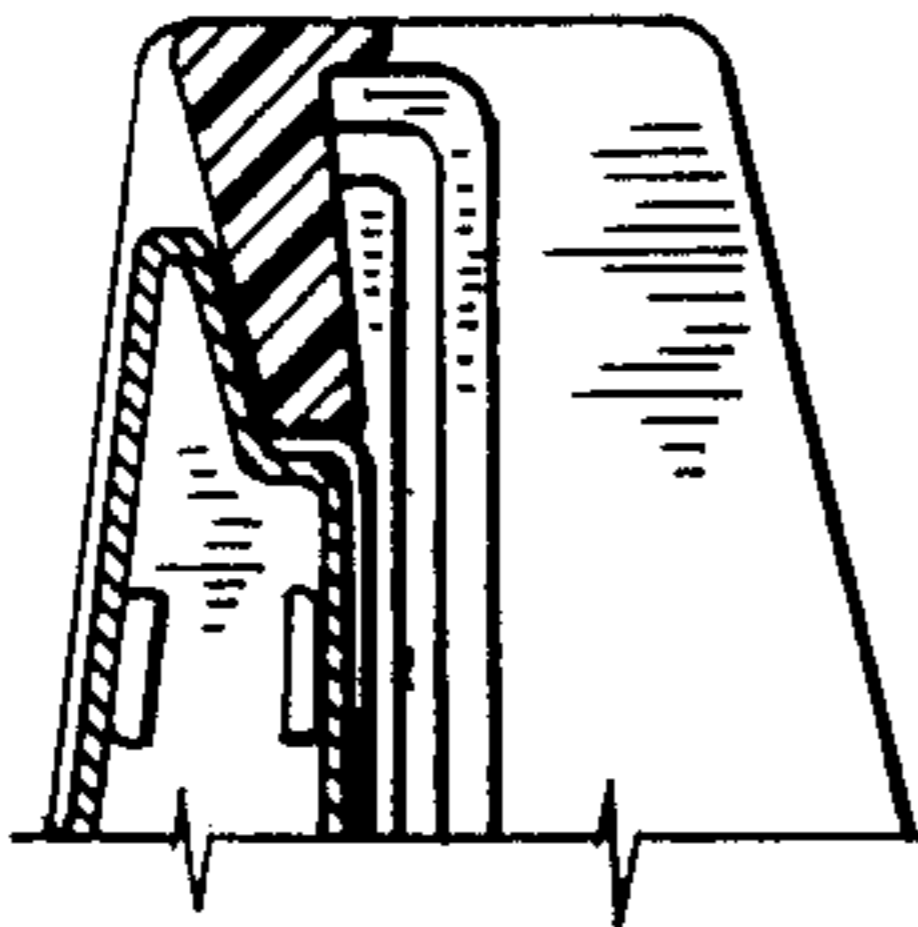

*Fig. 5*

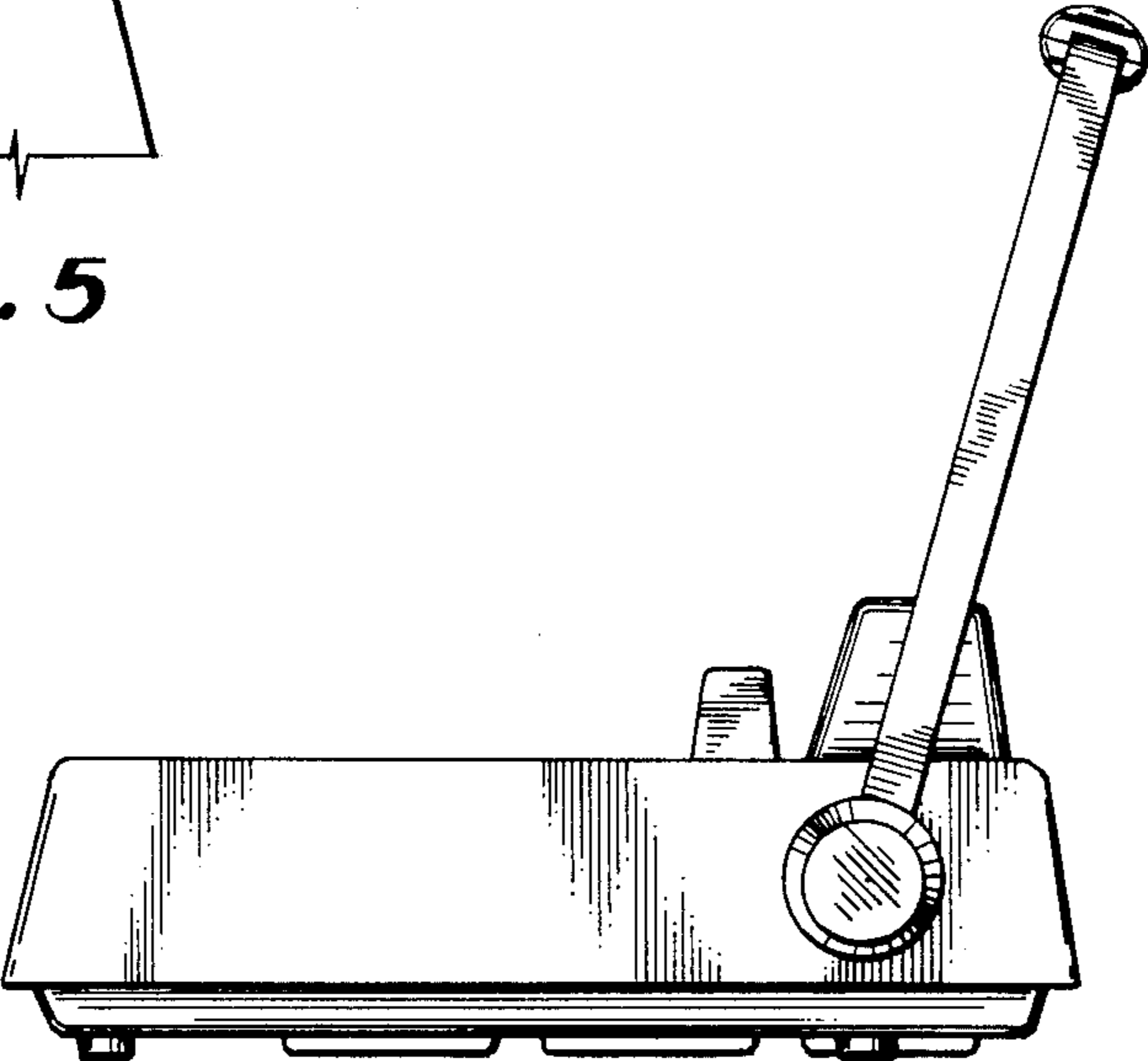

*Fig. 3*

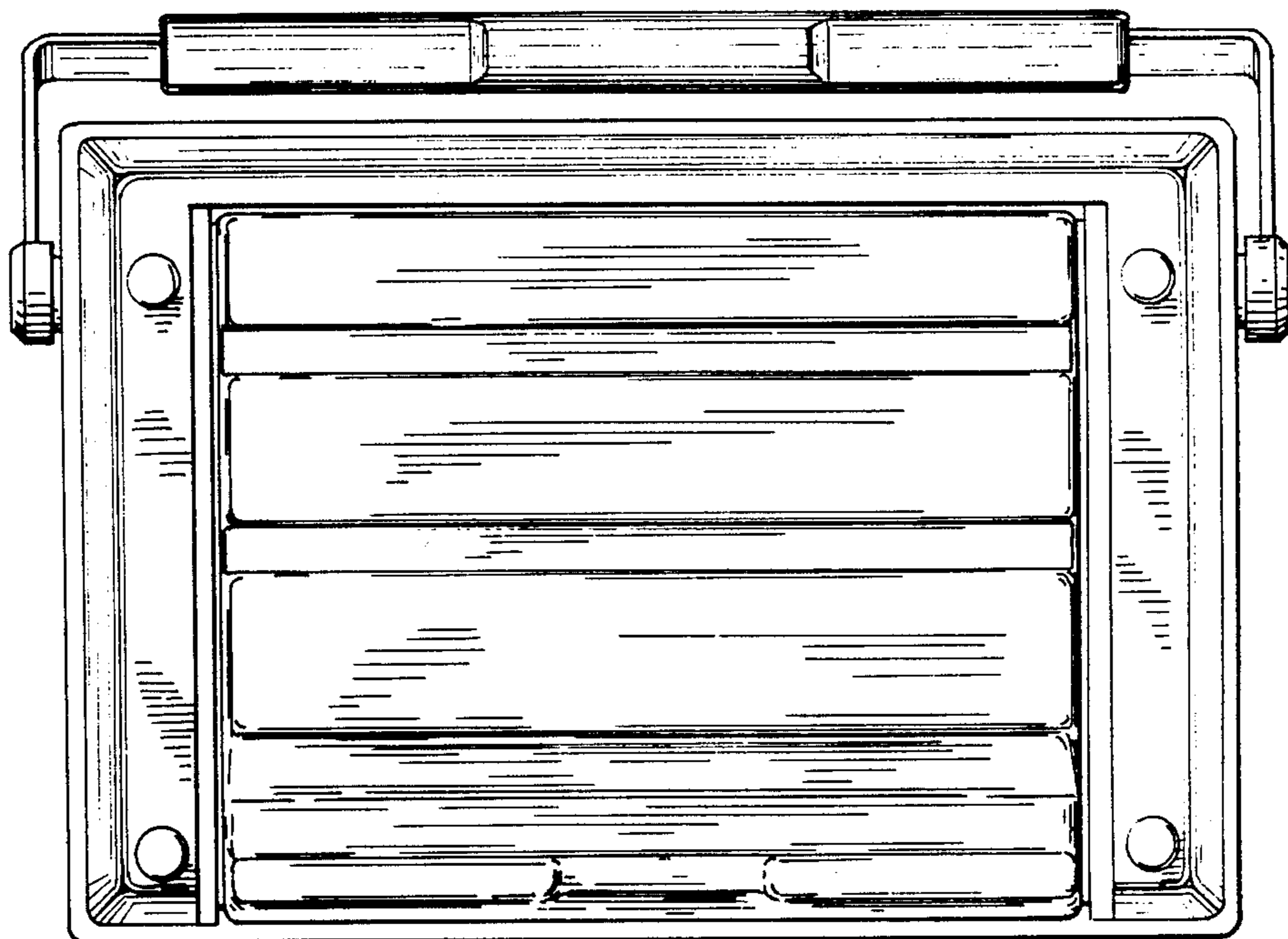

*Fig.6*