

[54] AIR BRAKE
[76] Inventor: Edward H. Clapp, 4117 Druid Hills,
Dallas, Tex. 75224
[**] Term: 14 Years
[21] Appl. No.: 678,176
[22] Filed: Apr. 19, 1976
[51] Int. Cl. D12-16
[52] U.S. Cl. D12/179
[58] Field of Search D12/179, 180; 188/170;
92/63, 64, 130

[56] References Cited
U.S. PATENT DOCUMENTS
3,101,133 8/1963 House et al. 188/170

3,613,515 10/1971 Swander, Jr. et al. 188/170
3,842,716 10/1974 Swander, Jr. 92/64

Primary Examiner—Wallace R. Burke
Assistant Examiner—James M. Gandy
Attorney, Agent, or Firm—D. Carl Richards

[57] CLAIM

The ornamental design for an air brake, as shown.

DESCRIPTION

FIG. 1 is a front elevational view of an air brake showing my new design;
FIG. 2 is a rear elevational view thereof;
FIG. 3 is a top plan view thereof;
FIG. 4 is a bottom plan view thereof;
FIG. 5 is a right side elevational view thereof; and
FIG. 6 is a left side elevational view thereof.

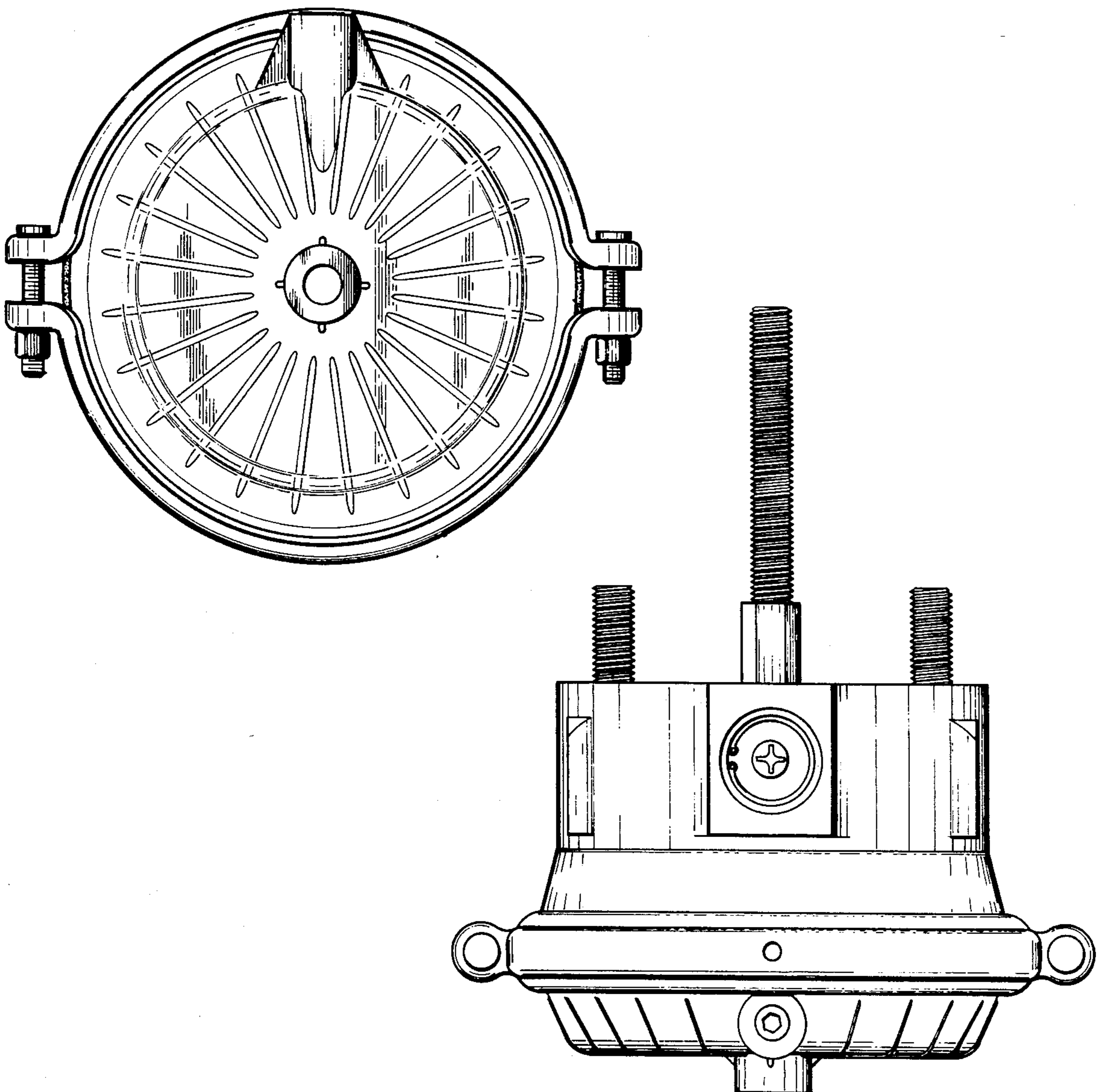

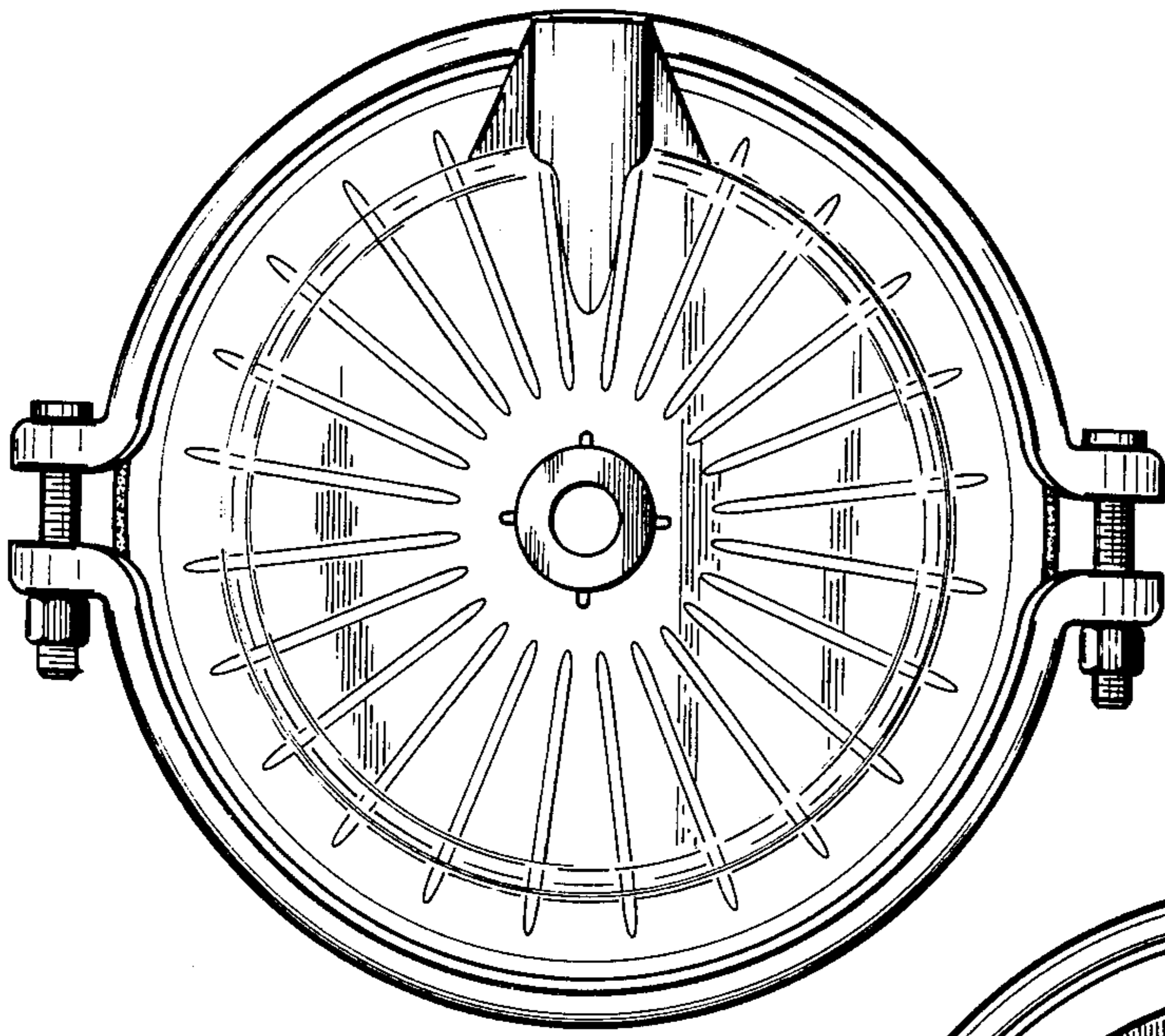

FIG. 1

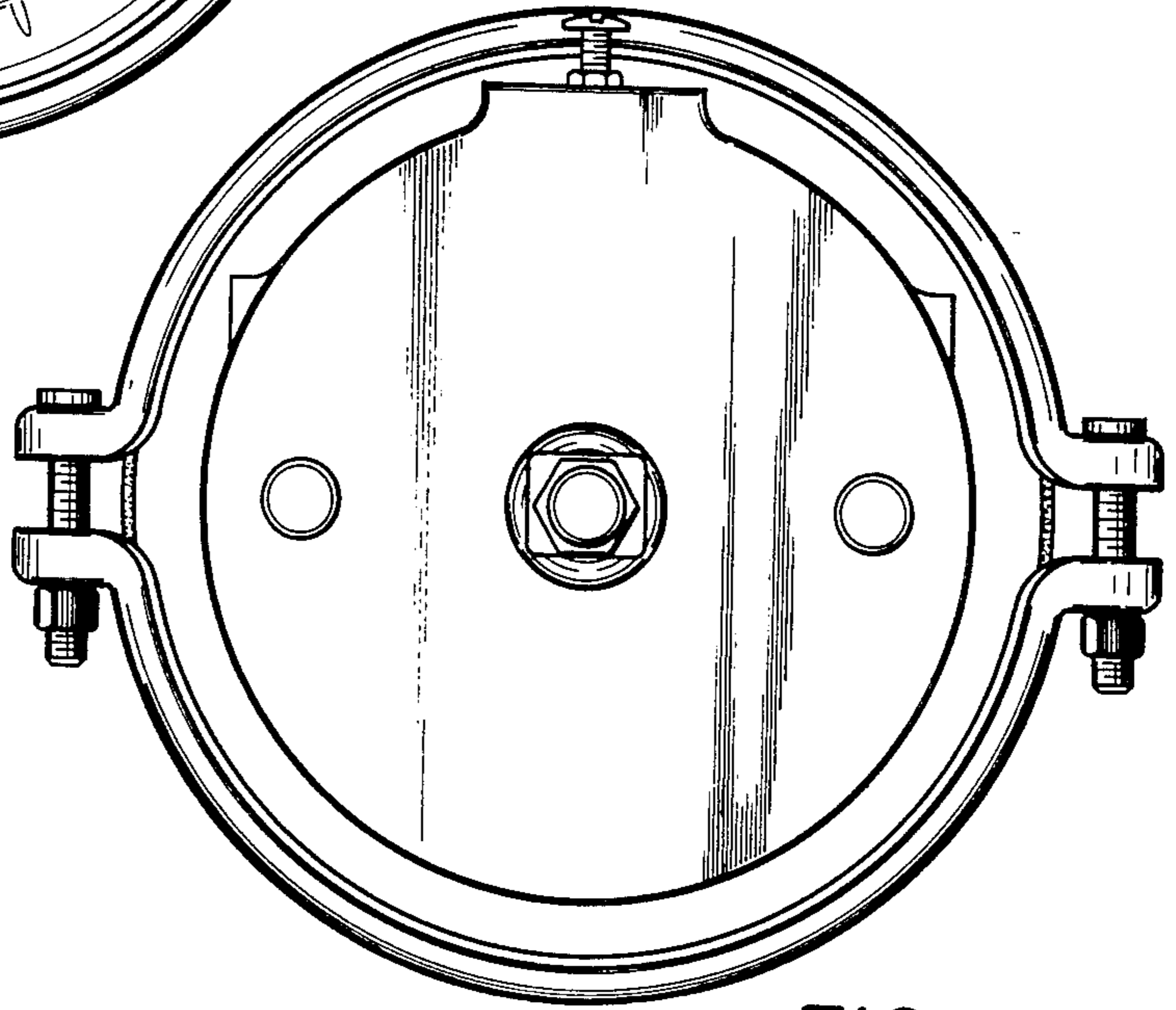

FIG. 2

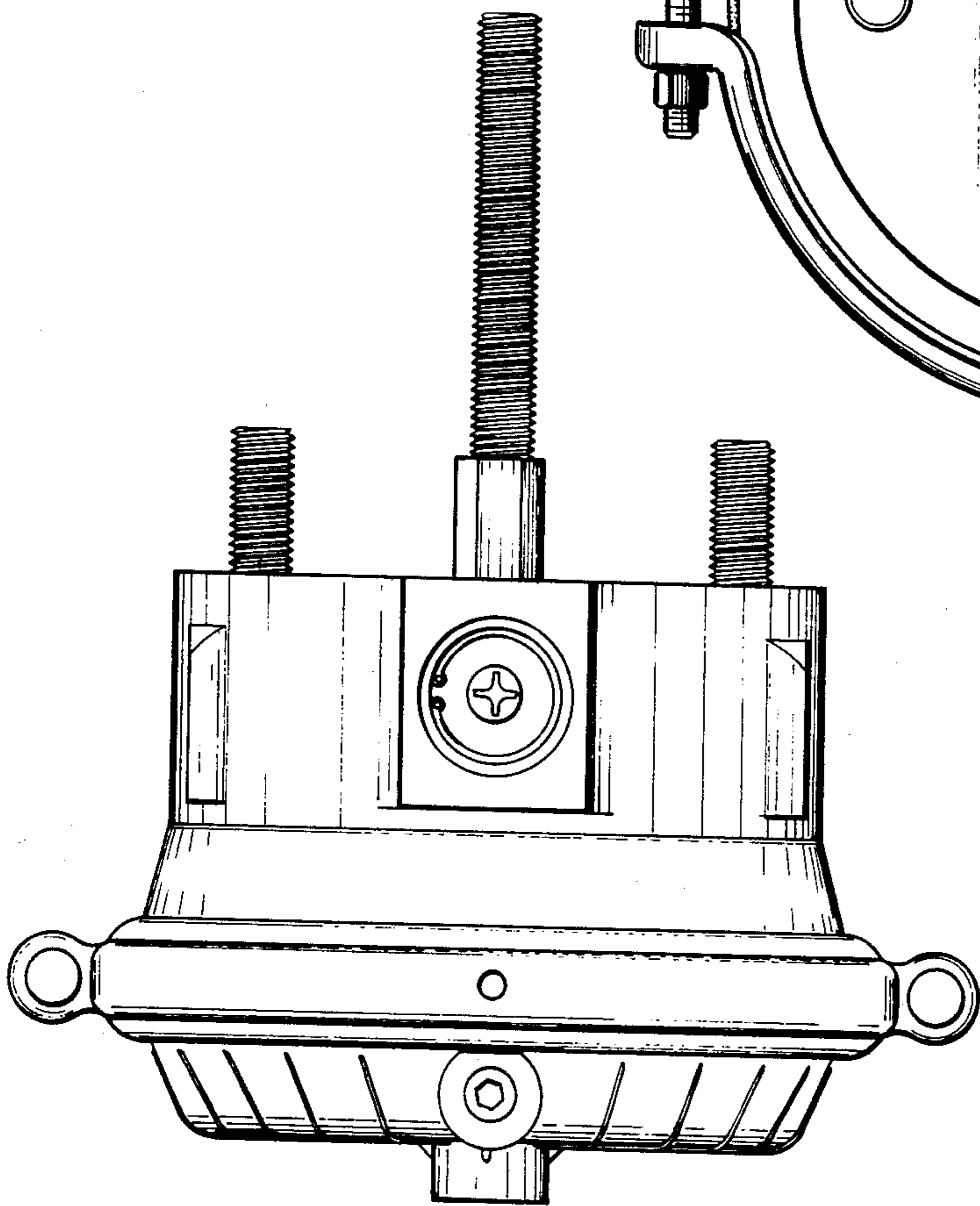

FIG. 3

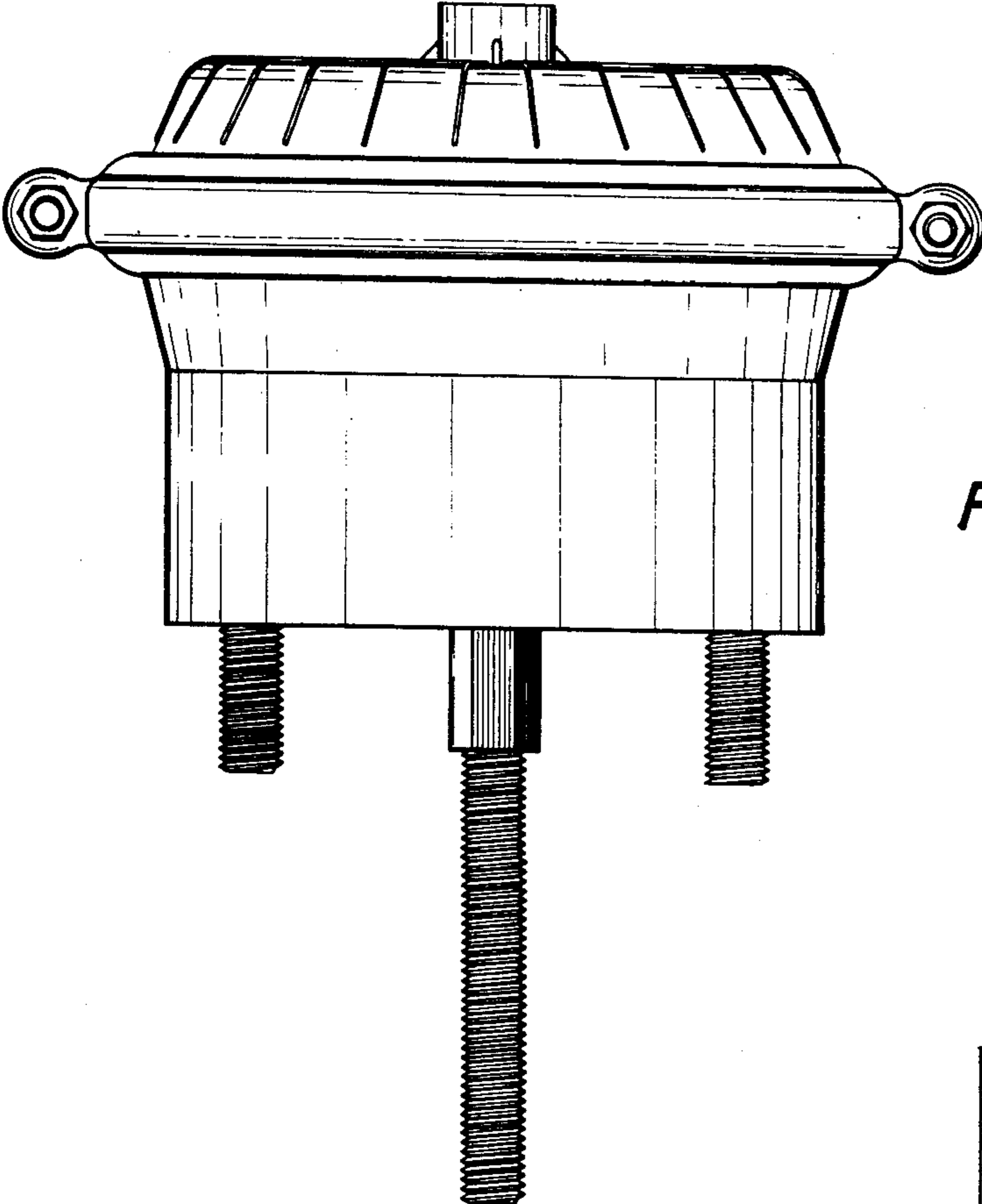

FIG. 4

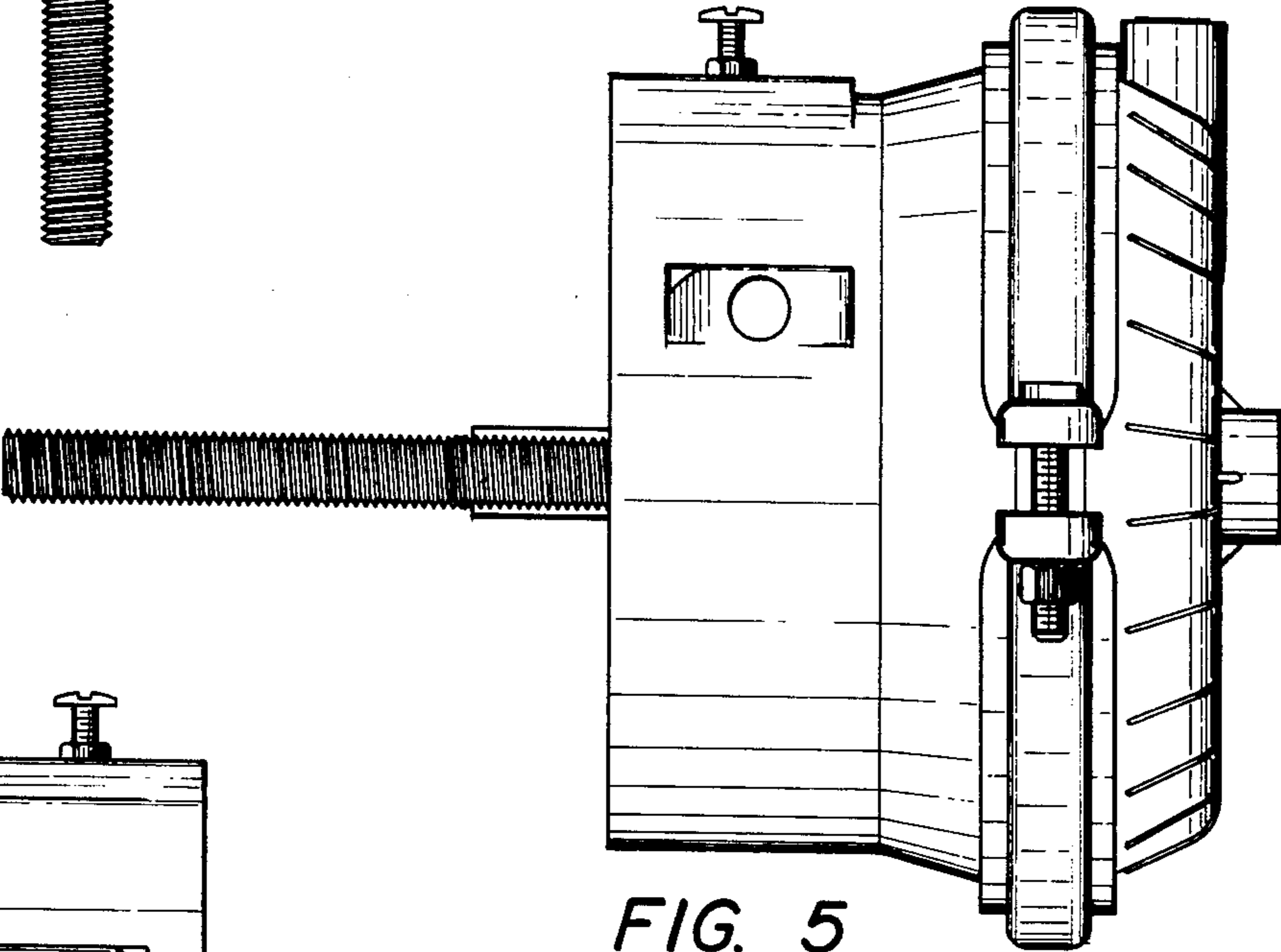

FIG. 5

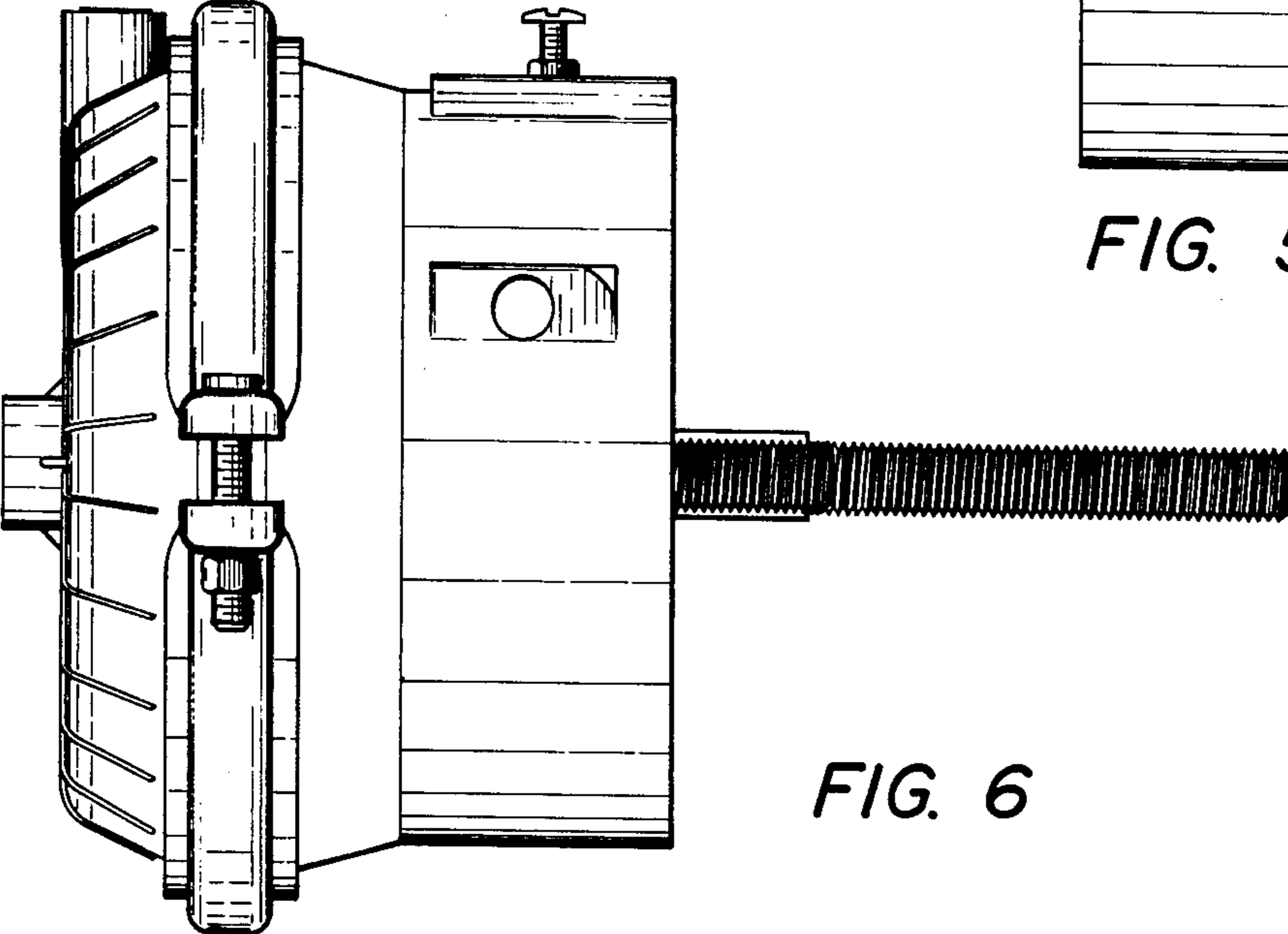

FIG. 6