

[54] COMBINED GOLF CAR AND REMOVABLE CANOPY THEREFOR

[75] Inventor: William G. Davidson, Elm Grove, Wis.

[73] Assignee: AMF Incorporated, White Plains, N.Y.

[**] Term: 14 Years

[21] Appl. No.: 645,797

[22] Filed: Dec. 31, 1975

[51] Int. Cl. D12-14

[52] U.S. Cl. D12/16

[58] Field of Search D12/16; 280/DIG. 5; 296/28 R; 180/89 R

[56] References Cited

U.S. PATENT DOCUMENTS

D. 205,504 8/1966 Gale D12/16

OTHER PUBLICATIONS

Gran Cushman Brochure, rec'd. Jan. 24, 1971, rear cover, Golf Car & Canopy, top of page.

The Trophy by Cushman, rec'd. Jan. 24, 1971, pp. 1 & 2, Golf Car & Canopy, bottom of page.

Caroche by Club Car, rec'd. Jan. 24, 1971, p. 2, Golf Car & Canopy, top of page.

Primary Examiner—Wallace R. Burke

Assistant Examiner—James M. Gandy

Attorney, Agent, or Firm—George W. Price

[57] CLAIM

The ornamental design for a combined golf car and removable canopy therefor, as shown.

DESCRIPTION

FIG. 1 is a perspective view of a combined golf car and removable canopy therefor showing my new design; FIG. 2 is an enlarged perspective view thereof with the canopy removed for convenience of illustration; FIG. 3 is a side elevational view of FIG. 2; FIG. 4 is a top plan view of FIG. 2; FIG. 5 is a rear elevational view of FIG. 2; FIG. 6 is a top plan view of the removable canopy with the golf car omitted for clarity of illustration; FIG. 7 is a side elevational view of FIG. 6; FIG. 8 is a bottom plan view of FIG. 6; FIG. 9 is a front elevational view of FIG. 6; and FIG. 10 is a rear elevational view of FIG. 6.

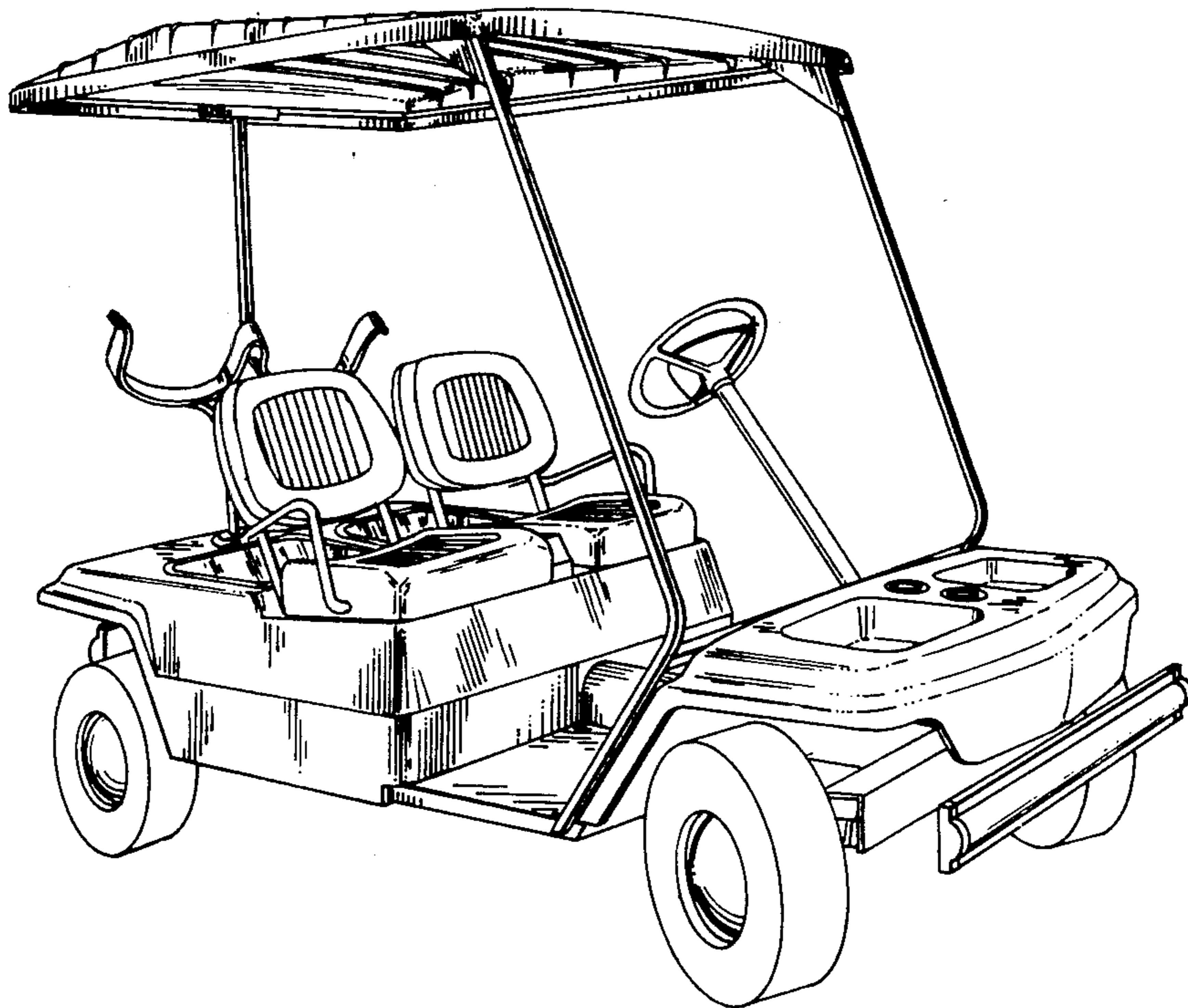

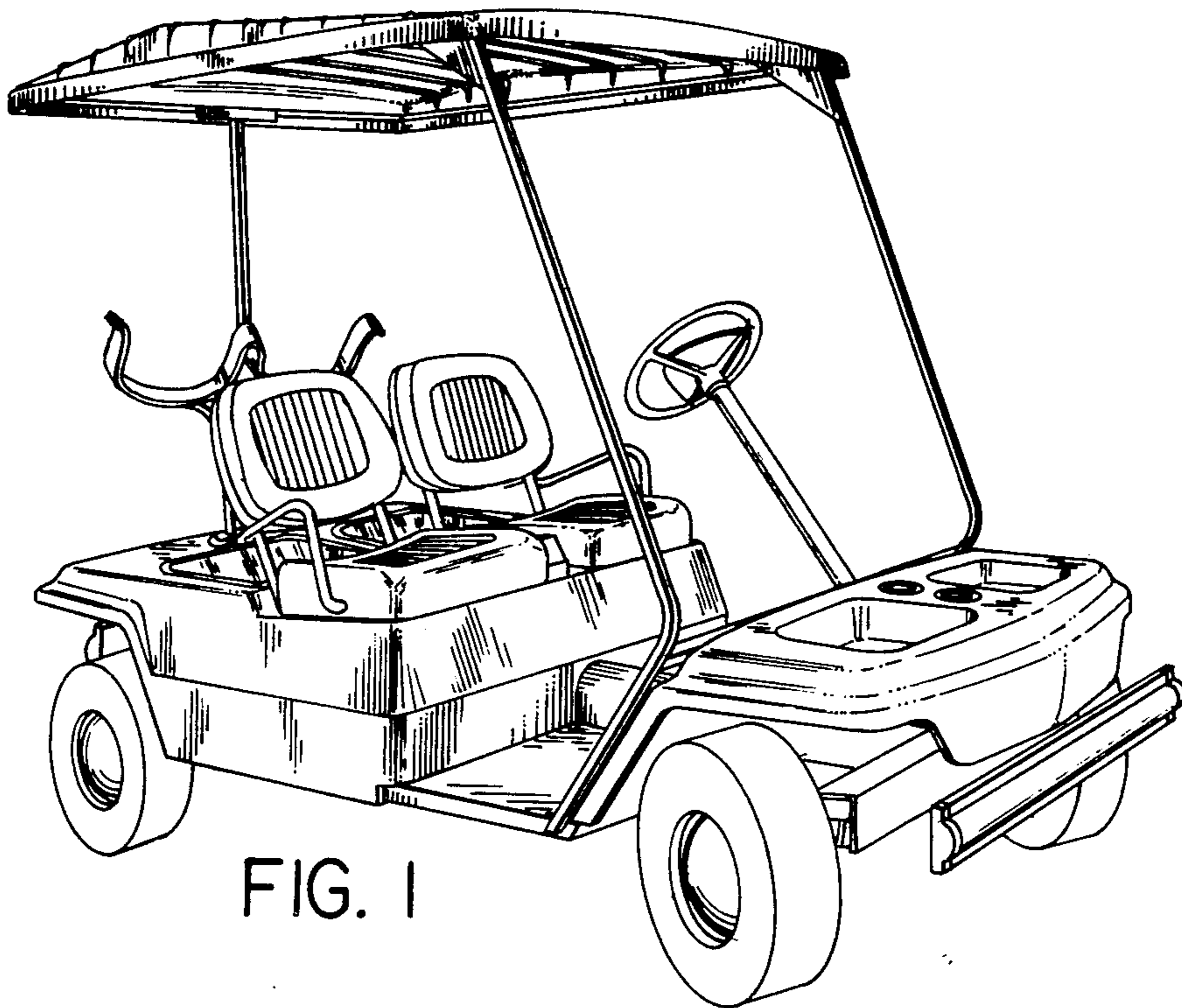

FIG. 1



FIG. 9



FIG. 6



FIG. 10



FIG. 7

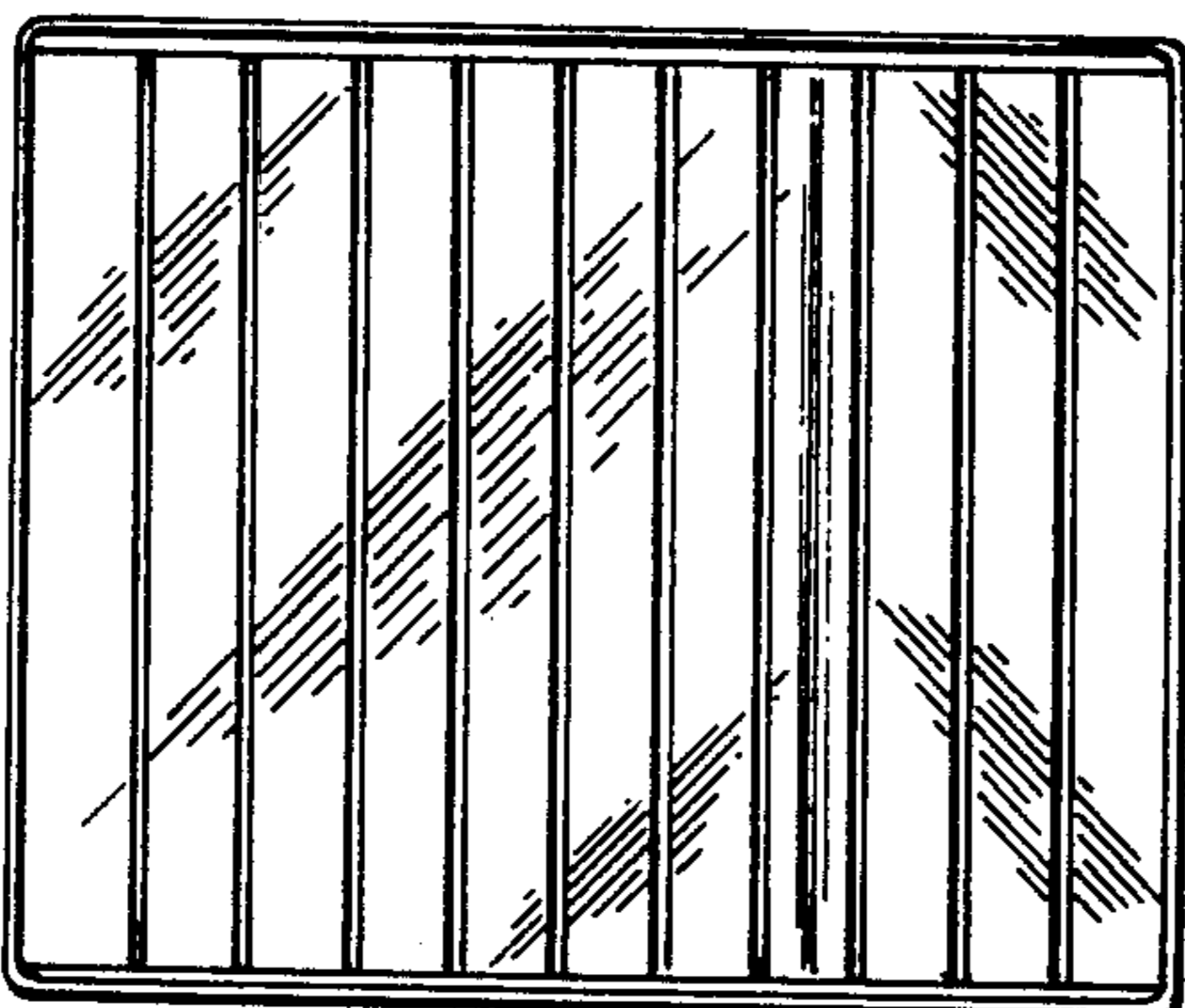

FIG. 8

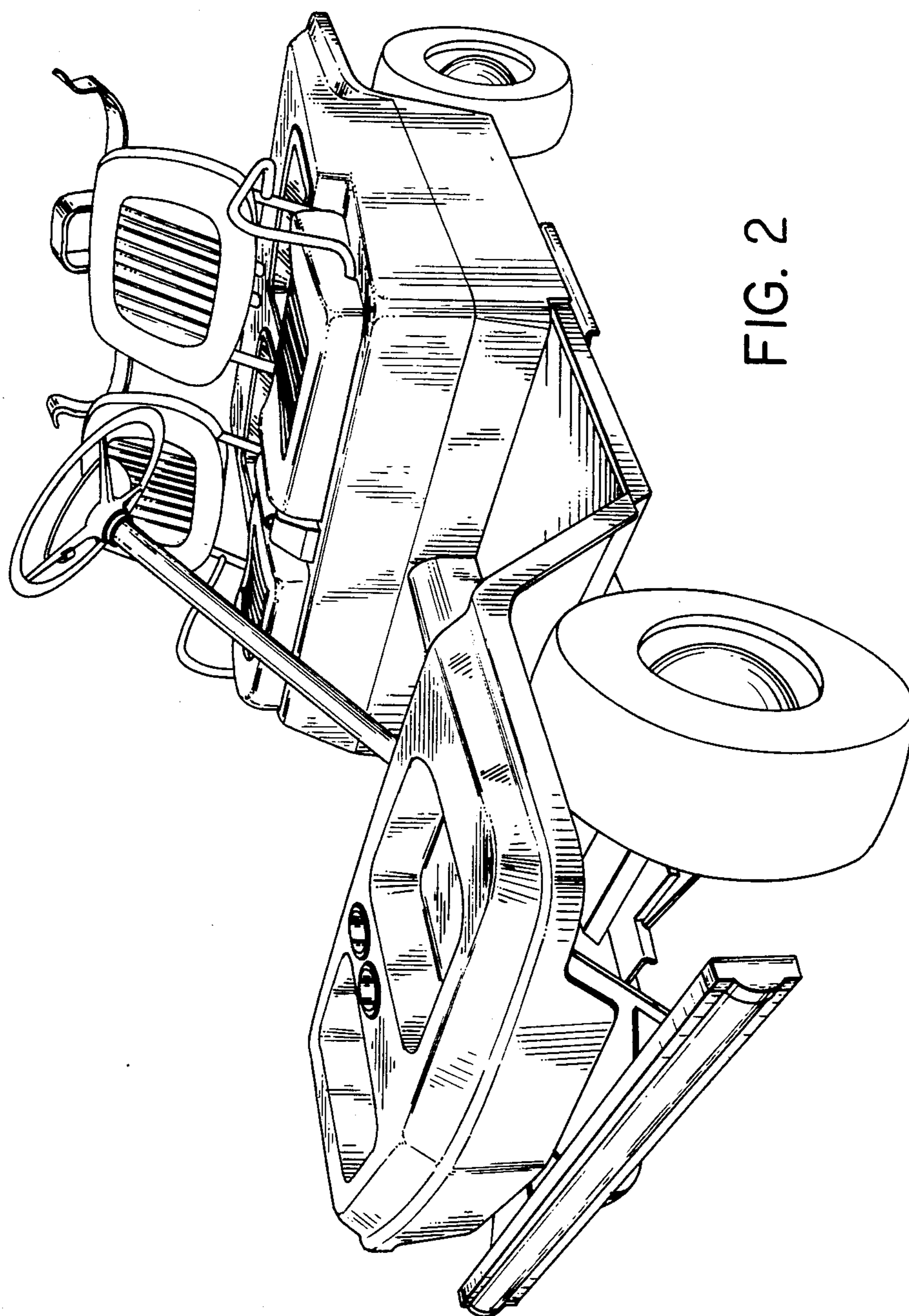

FIG. 2

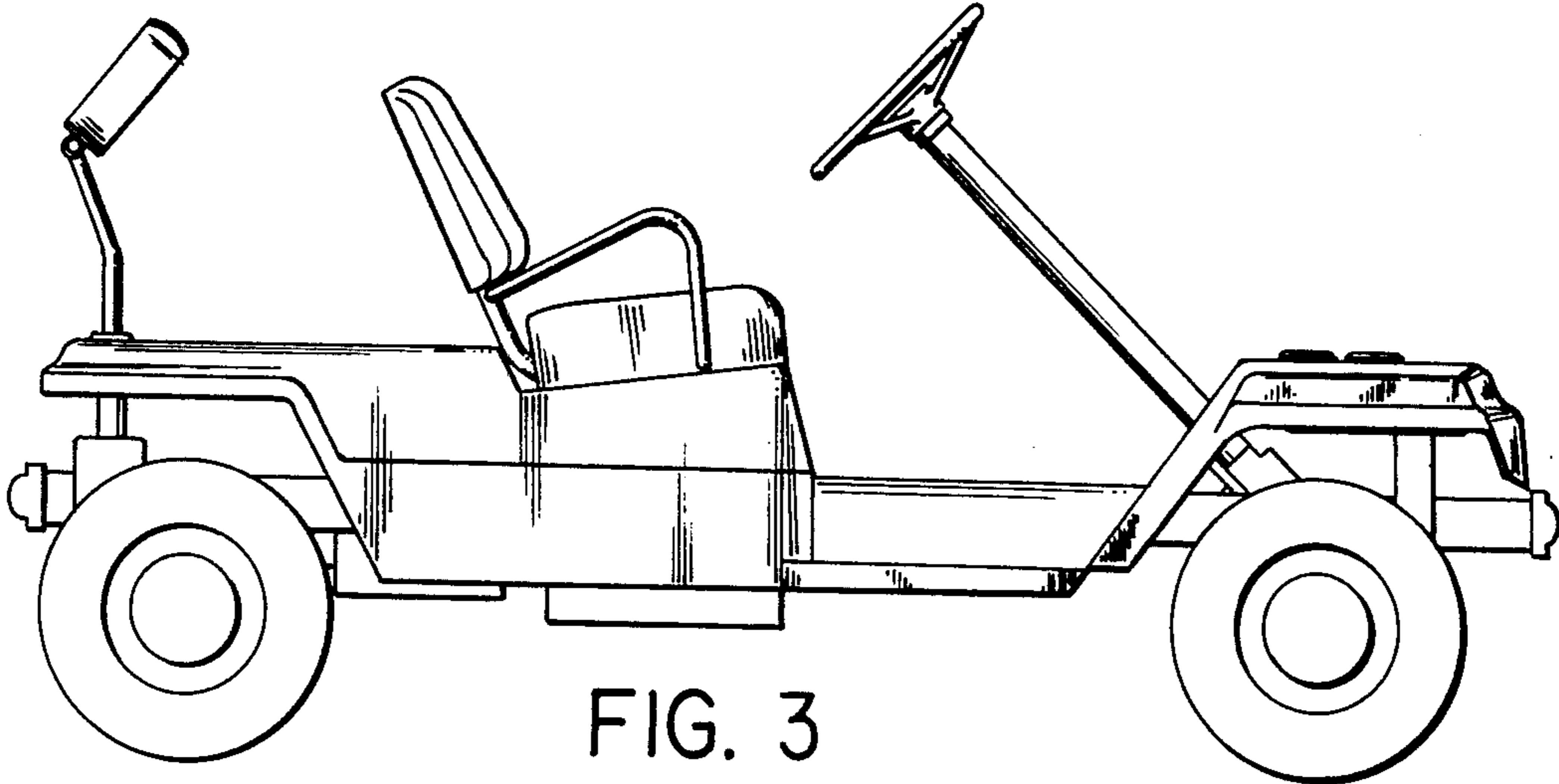

FIG. 3

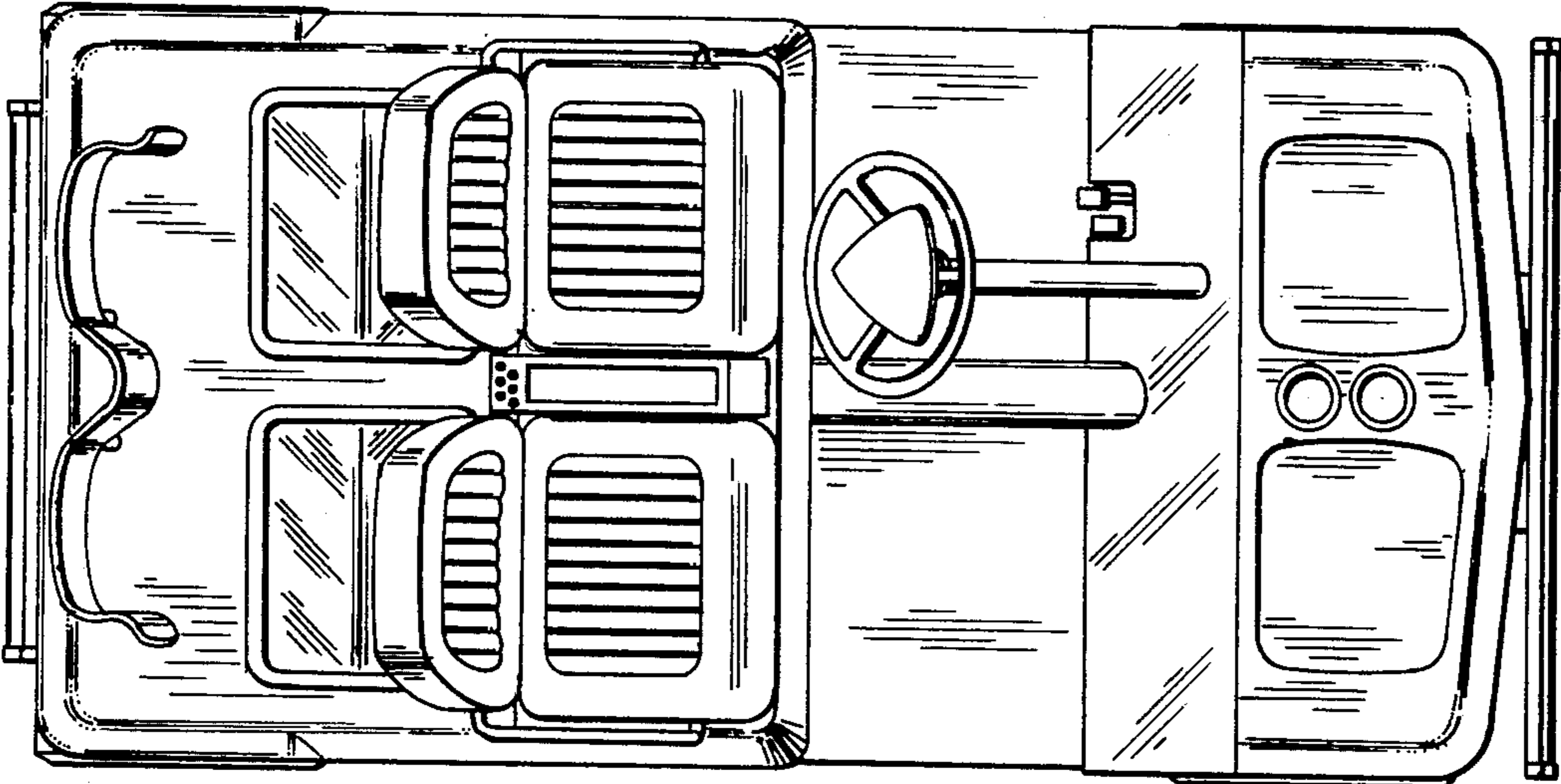

FIG. 4

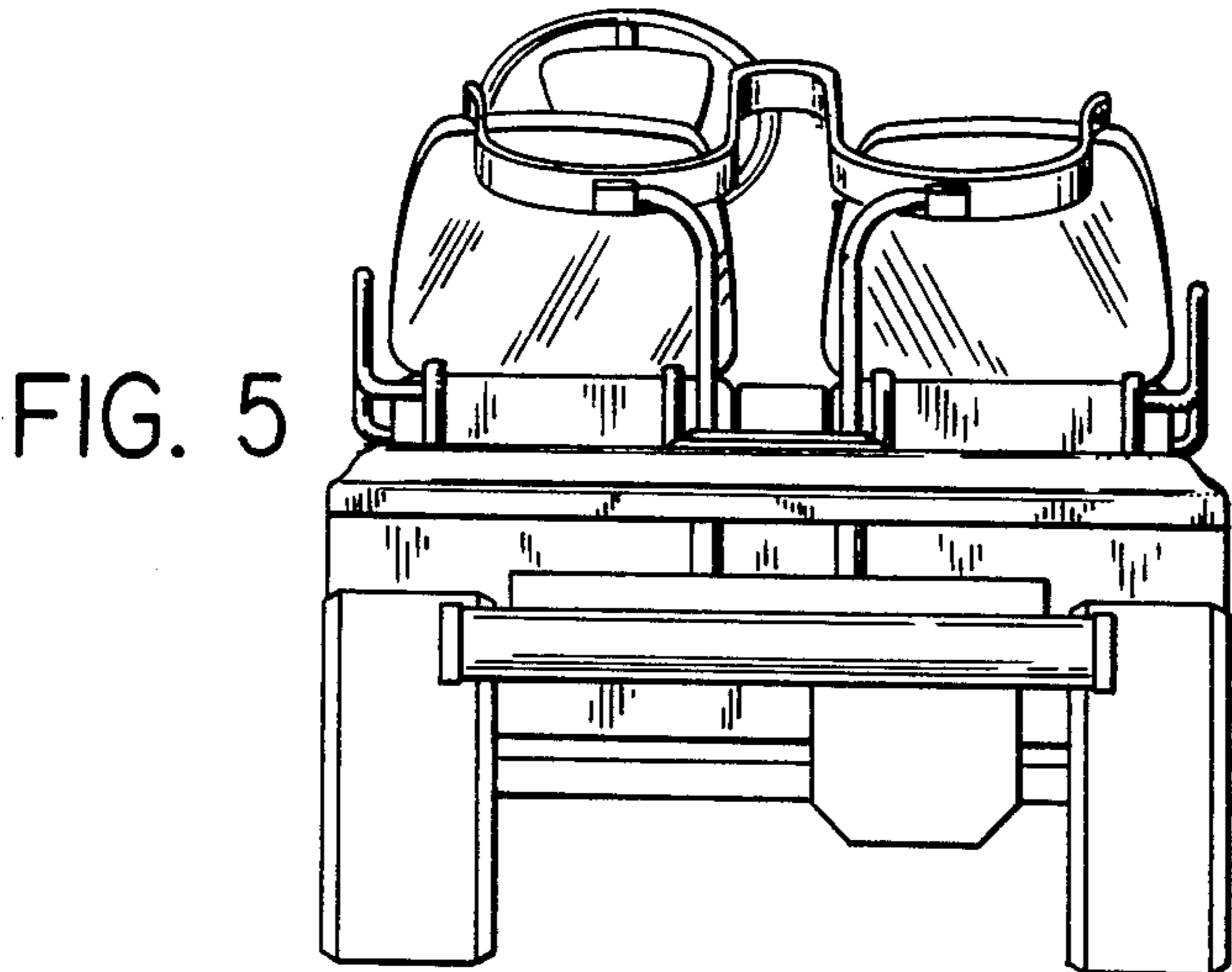

FIG. 5