

[54] ADHESIVE DISPENSER

[75] Inventor: Charles H. Scholl, Vermilion, Ohio

[73] Assignee: Nordson Corporation, Amherst, Ohio

[**] Term: 14 Years

[21] Appl. No.: 565,933

[22] Filed: Apr. 7, 1975

[51] Int. Cl. D8-05

[52] U.S. Cl. D8/30

[58] Field of Search D8/30; 222/146 HE

[56] References Cited

U.S. PATENT DOCUMENTS

3,543,968	12/1970	Reighard	222/146
3,744,921	7/1973	Weller et al.	401/2
3,877,610	4/1975	Dickey	222/146 HE
D. 221,728	9/1971	Rosen et al.	D8/30
D. 226,750	4/1973	Grossman	D8/30
D. 232,619	9/1974	Crum	D8/30

OTHER PUBLICATIONS

Adhesive Machinery Corporation brochure, rec'd Apr. 20, 1973, hot melt gun on p. 3.

Primary Examiner—Alan P. Douglas
Attorney, Agent, or Firm—Thomas L. Moorhead

[57] CLAIM

The ornamental design for an adhesive dispenser, substantially as shown and described.

DESCRIPTION

FIG. 1 is a perspective view taken from the left front side of a first embodiment of an adhesive gun showing my new design;

FIG. 2 is a perspective view of the right side of that first embodiment shown in FIG. 1;

FIG. 3 is a top view of that first embodiment shown in FIG. 2;

FIG. 4 is a frontal view of that first embodiment shown in FIG. 1;

FIG. 5 is a bottom view of that first embodiment shown in FIG. 1;

FIG. 6 is a rear view of that first embodiment shown in FIG. 1;

FIG. 7 is a perspective view taken from the right front side of a second embodiment of an adhesive gun showing my new design with a portion in an alternate position;

FIG. 8 is a perspective view taken from the left front side of that second embodiment shown in FIG. 7;

FIG. 9 is an elevation view taken from the right side of that second embodiment shown in FIG. 7;

FIG. 10 is a bottom view of that second embodiment shown in FIG. 7;

FIG. 11 is an elevational view taken on the left side of that second embodiment shown in FIG. 7;

FIG. 12 is a rear view of that second embodiment shown in FIG. 7.

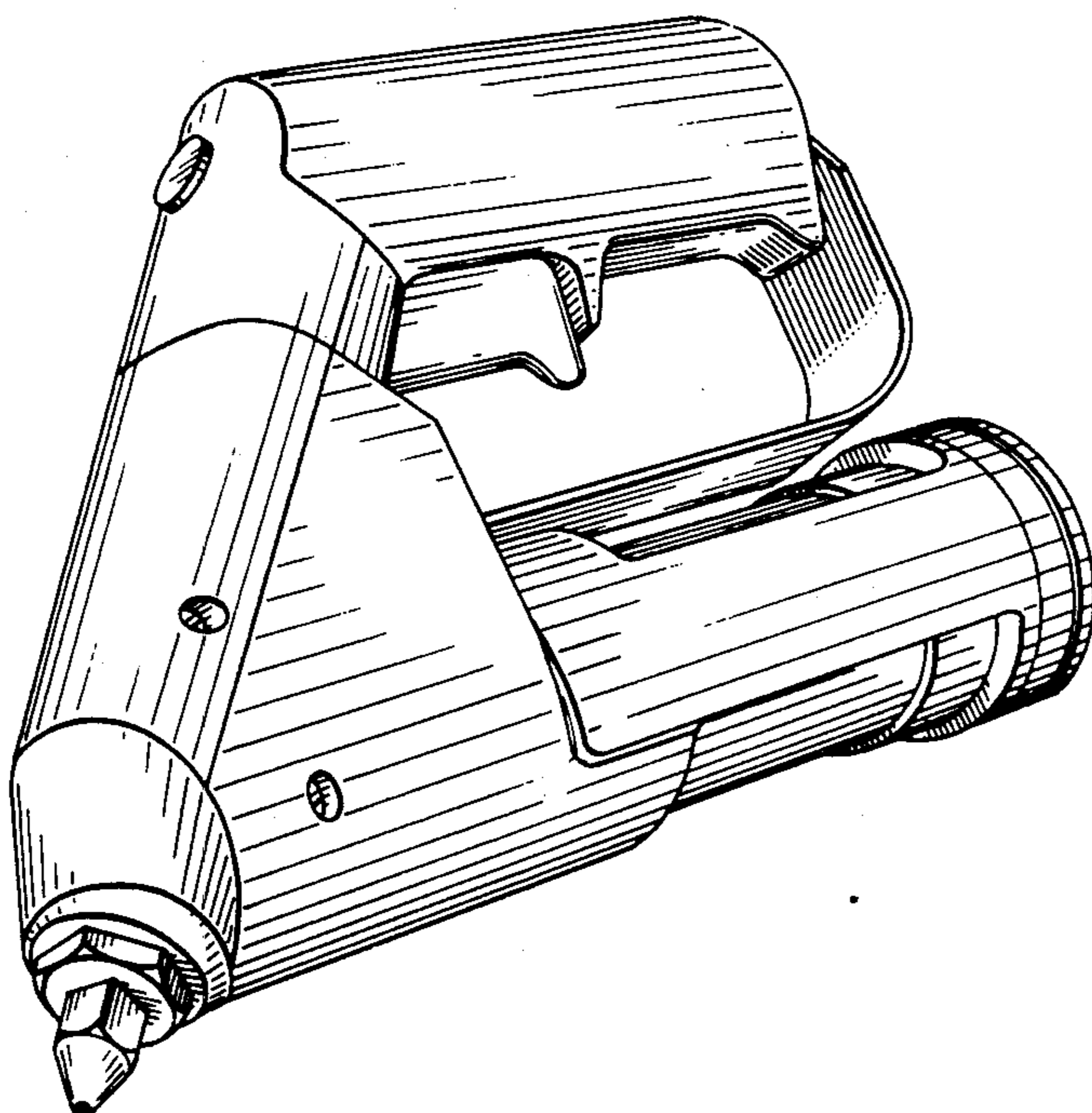

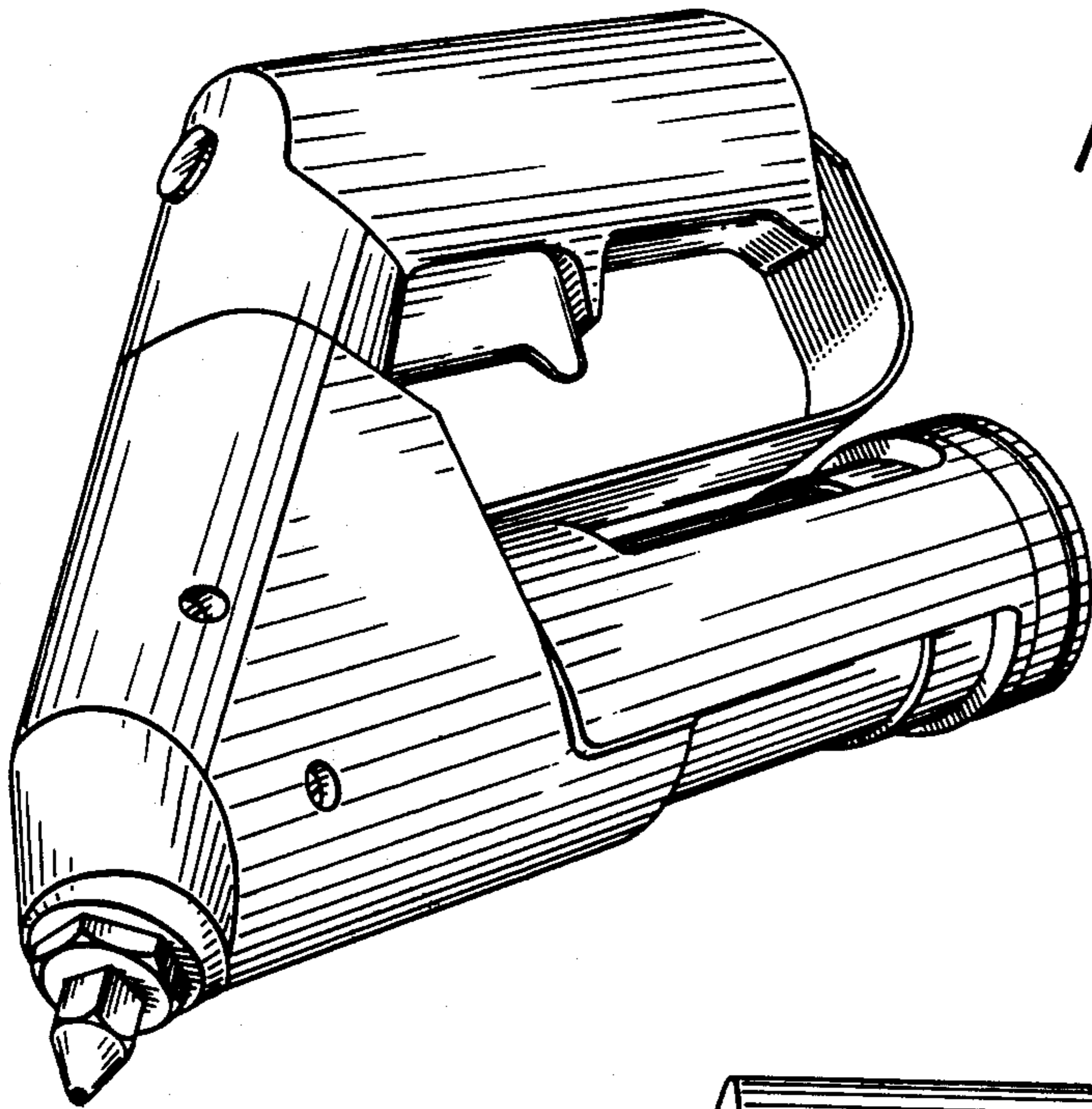

FIG. 1

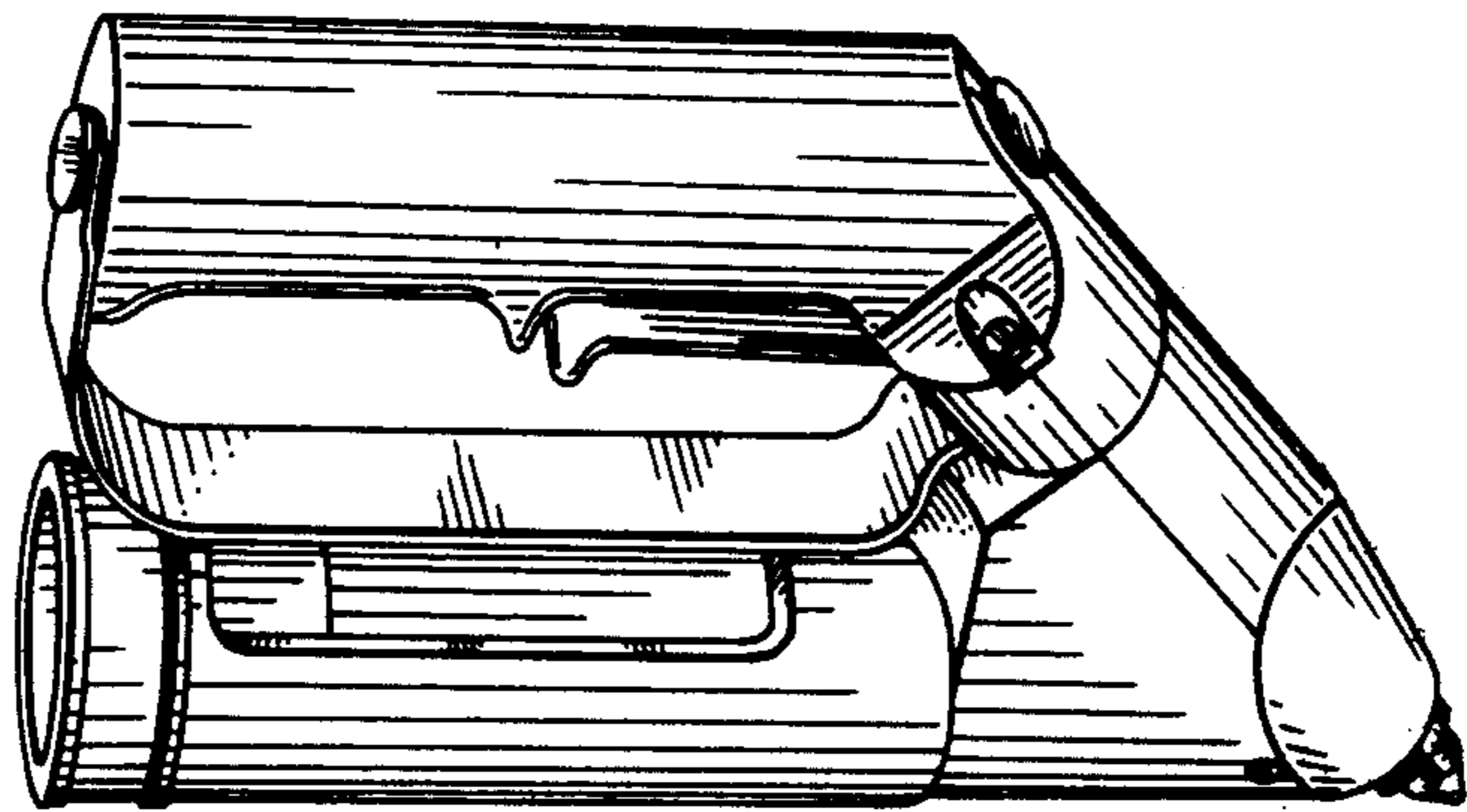

FIG. 2

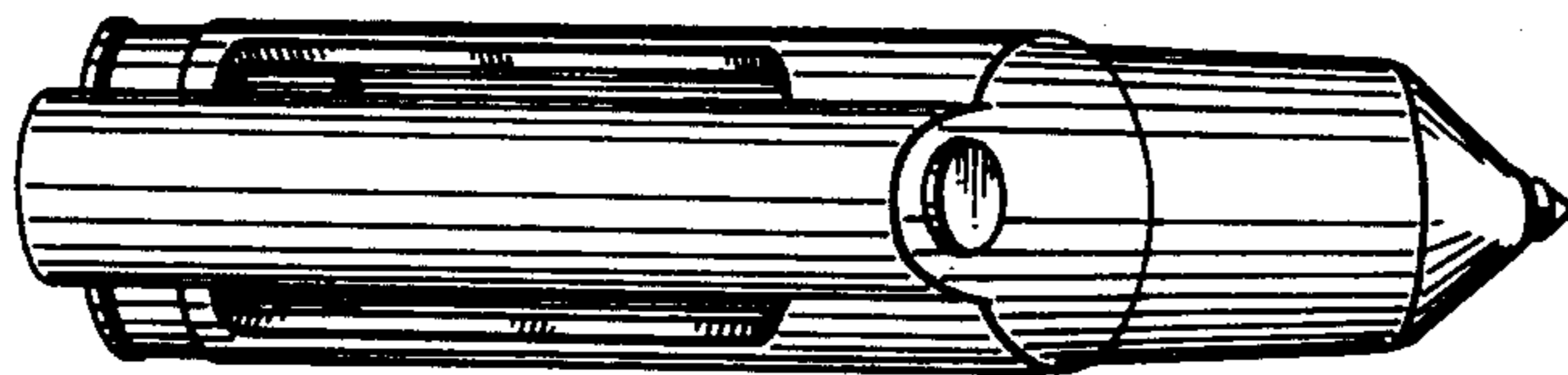

FIG. 3

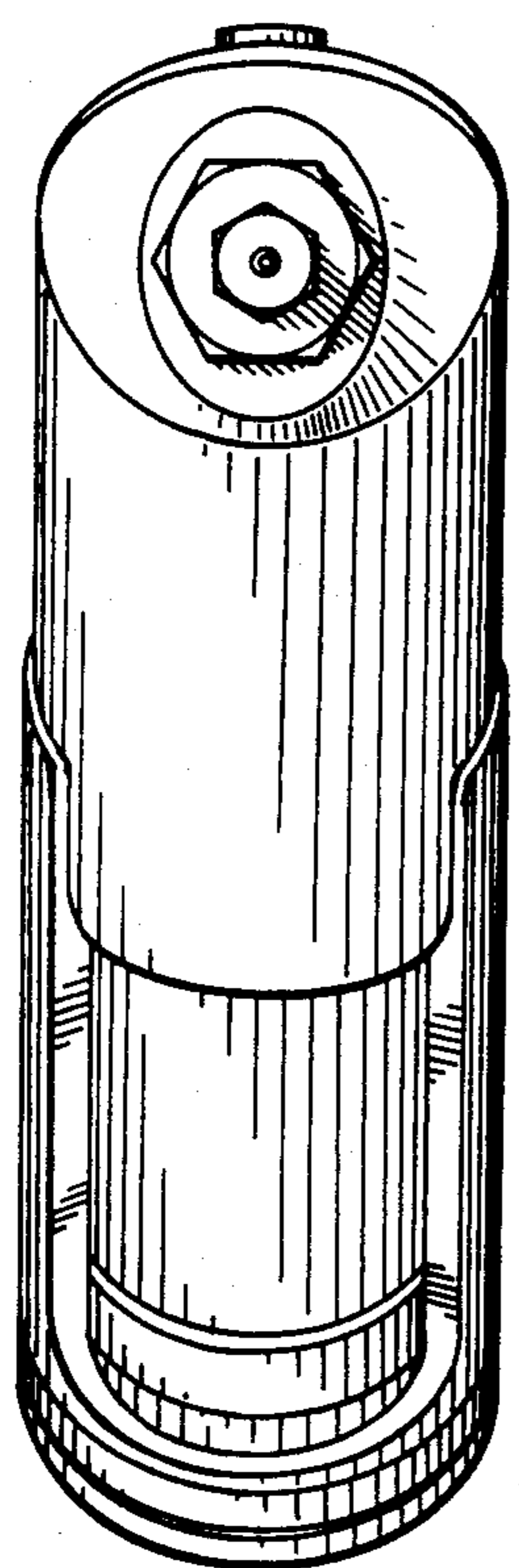

FIG. 4

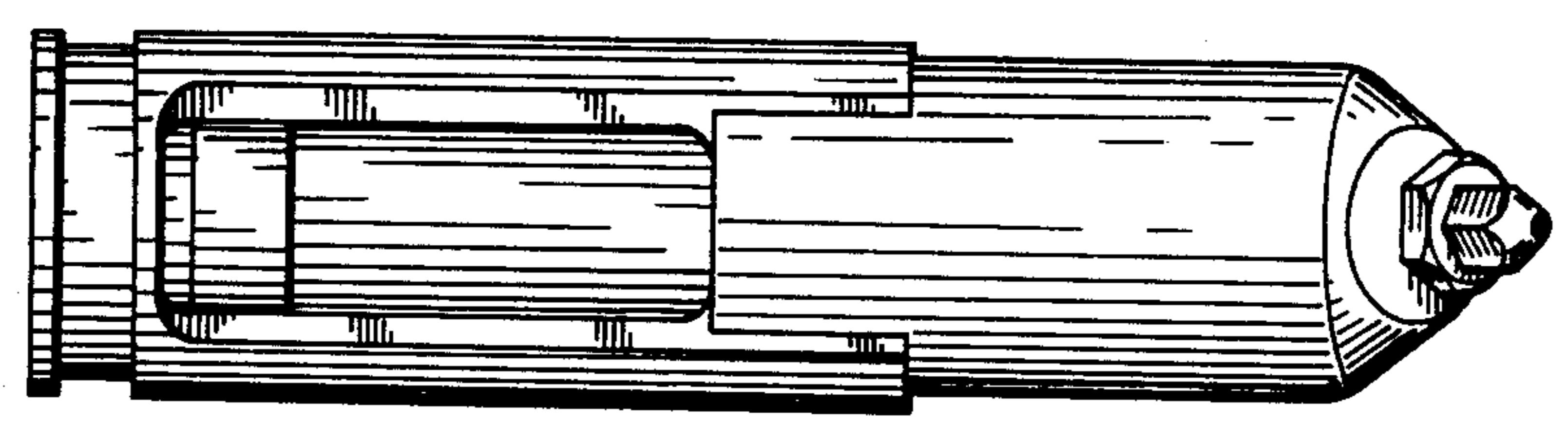

FIG. 5

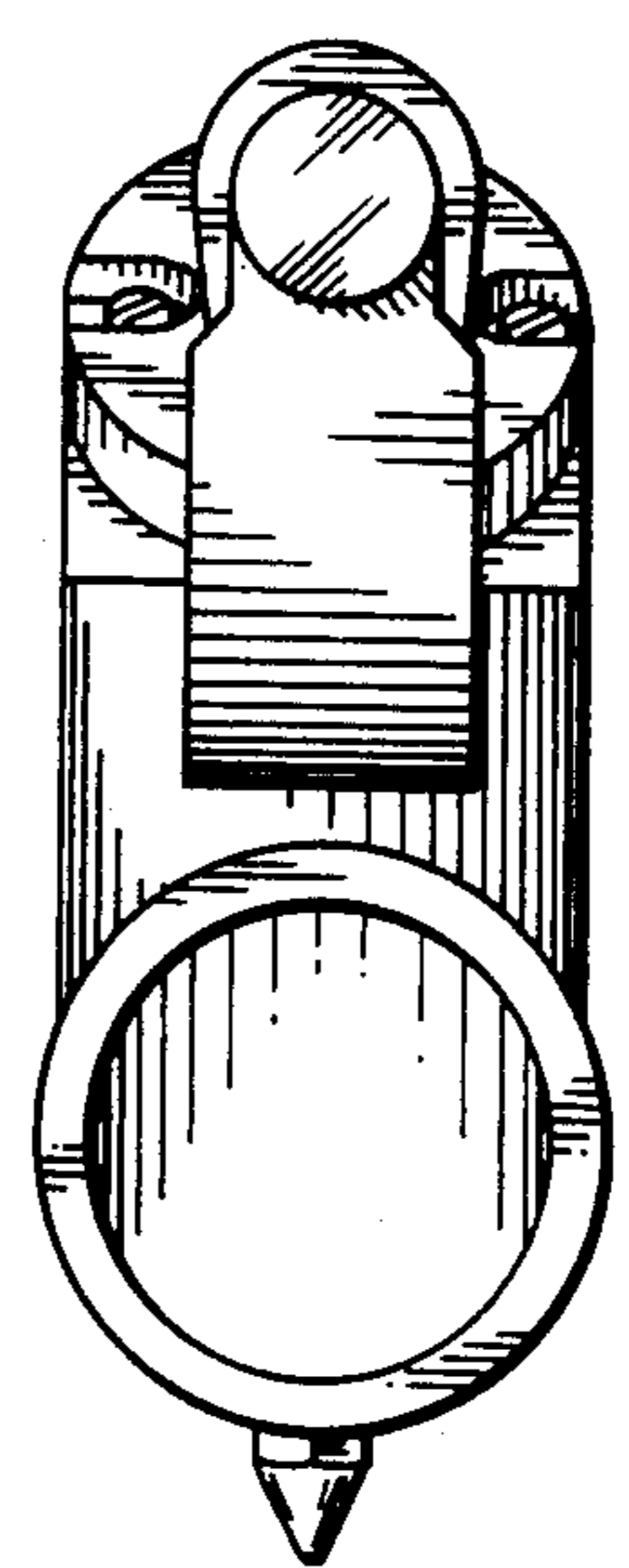

FIG. 6

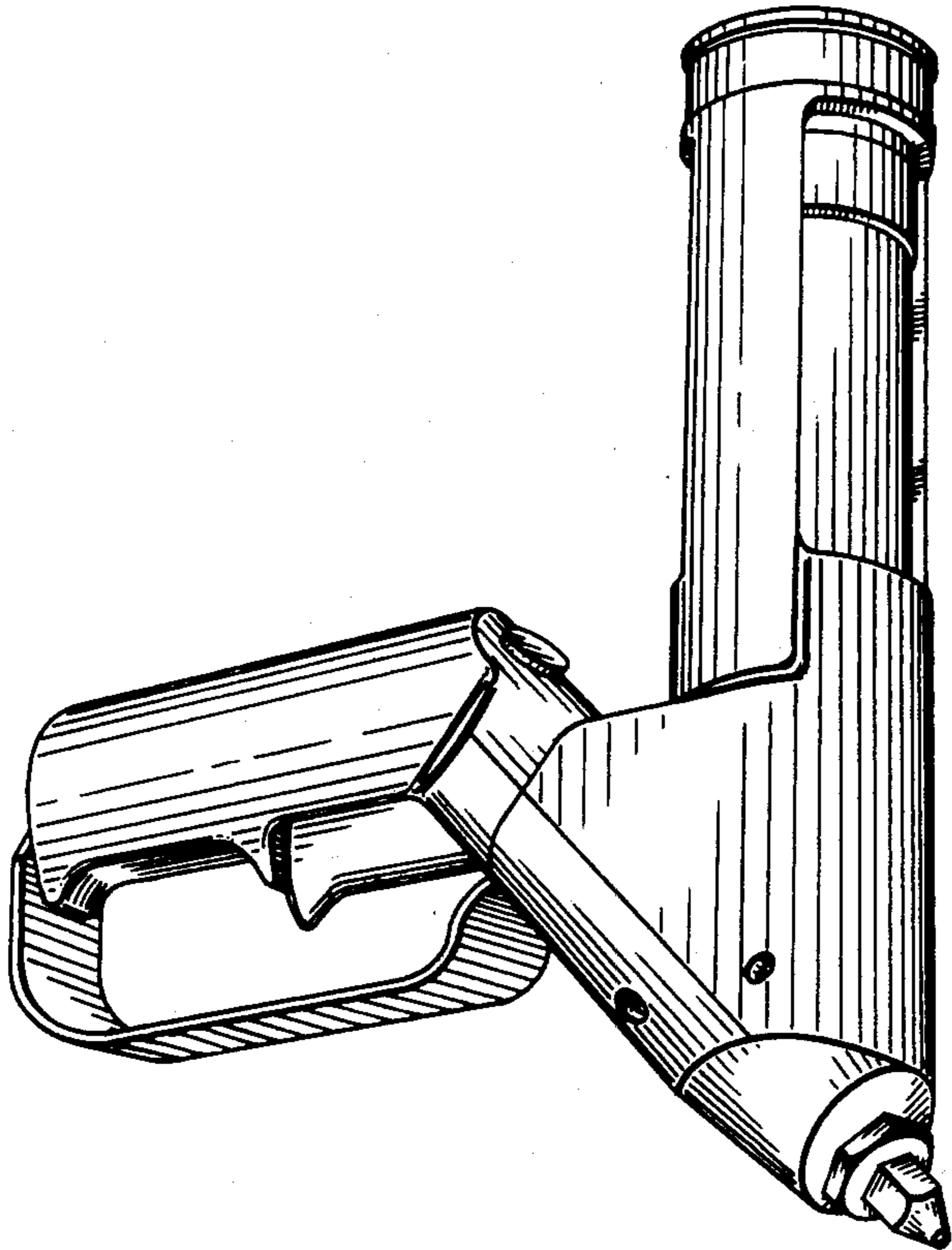

FIG. 7

FIG. 8

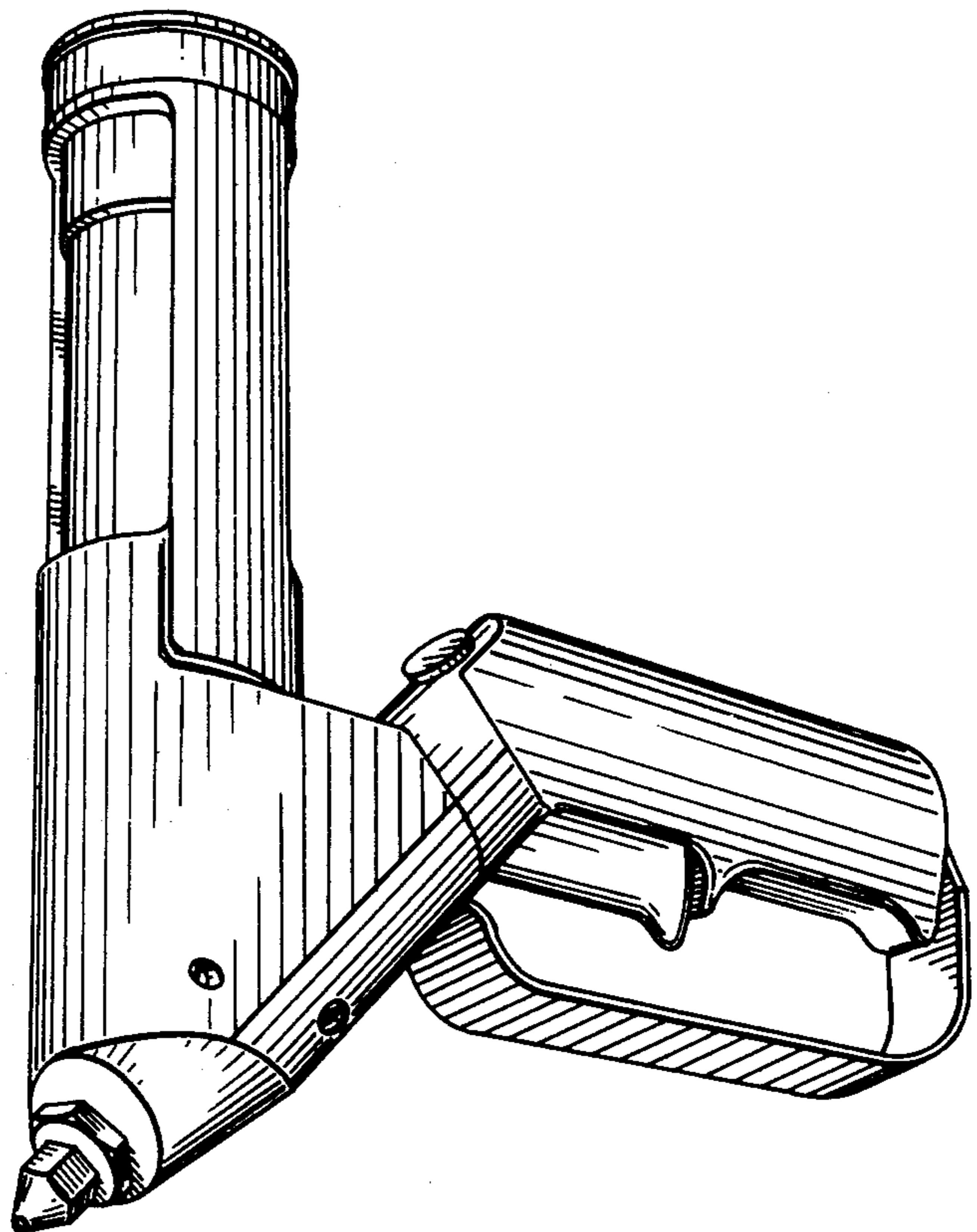

FIG. 9

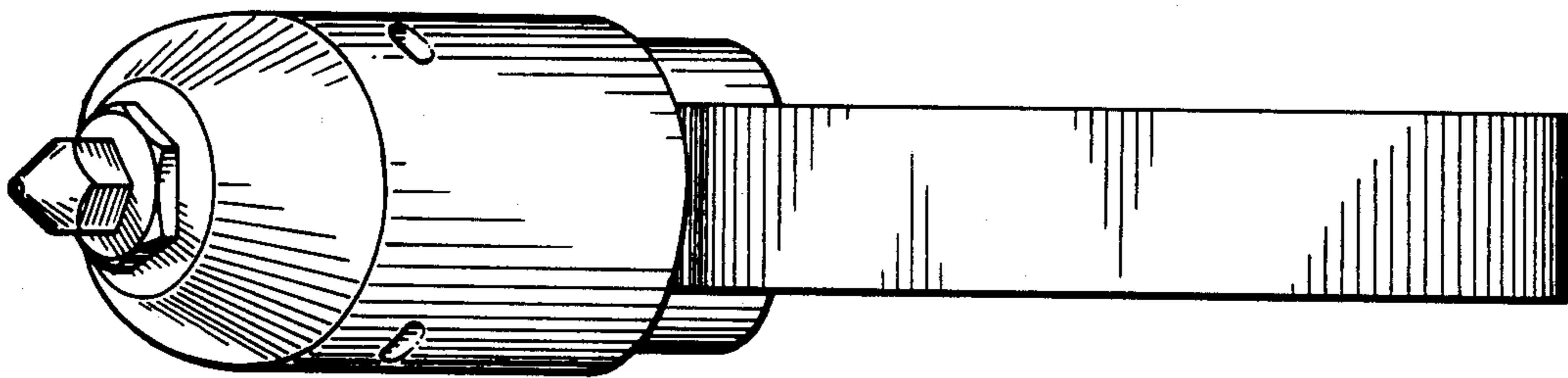
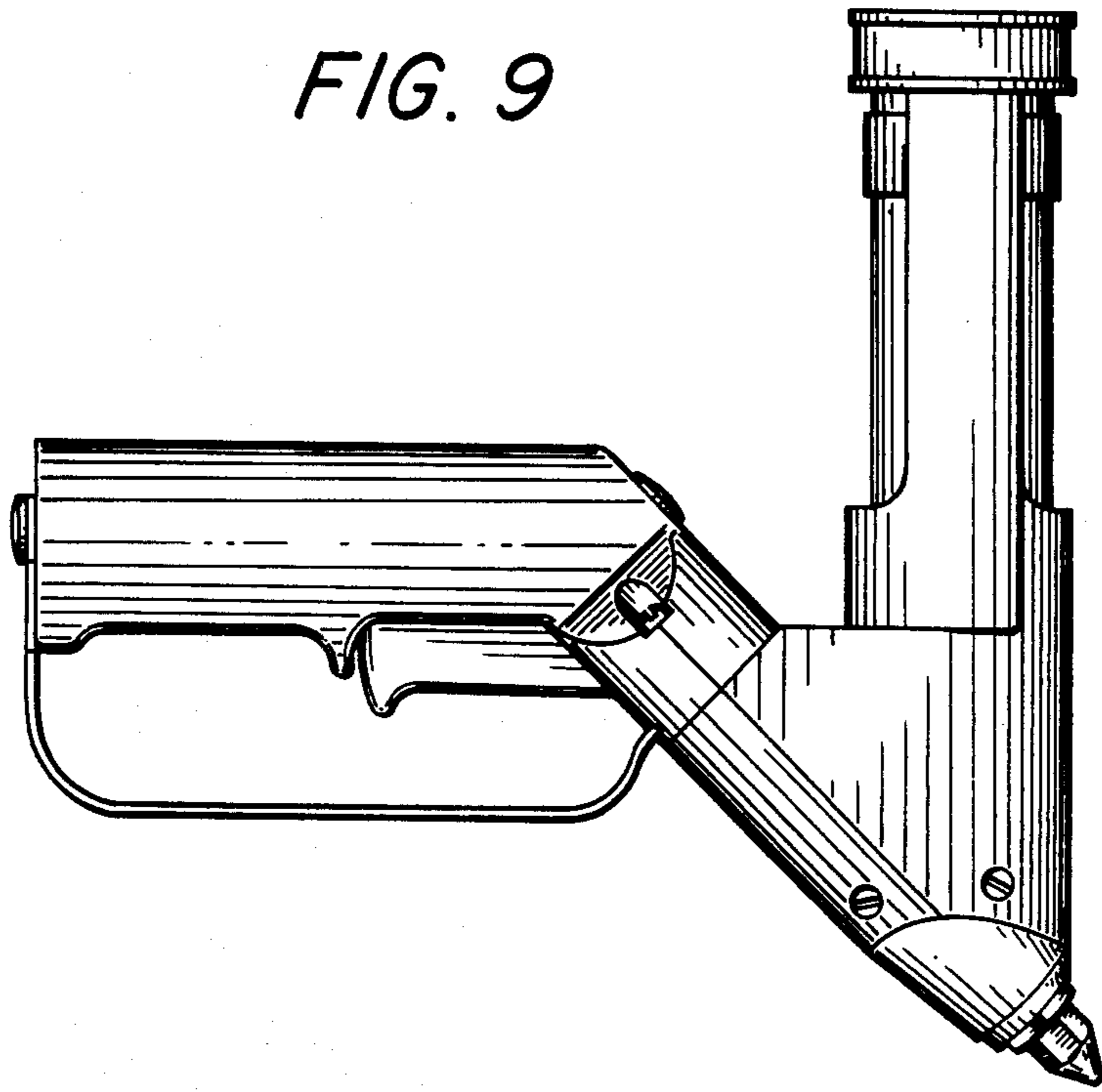

FIG. 10

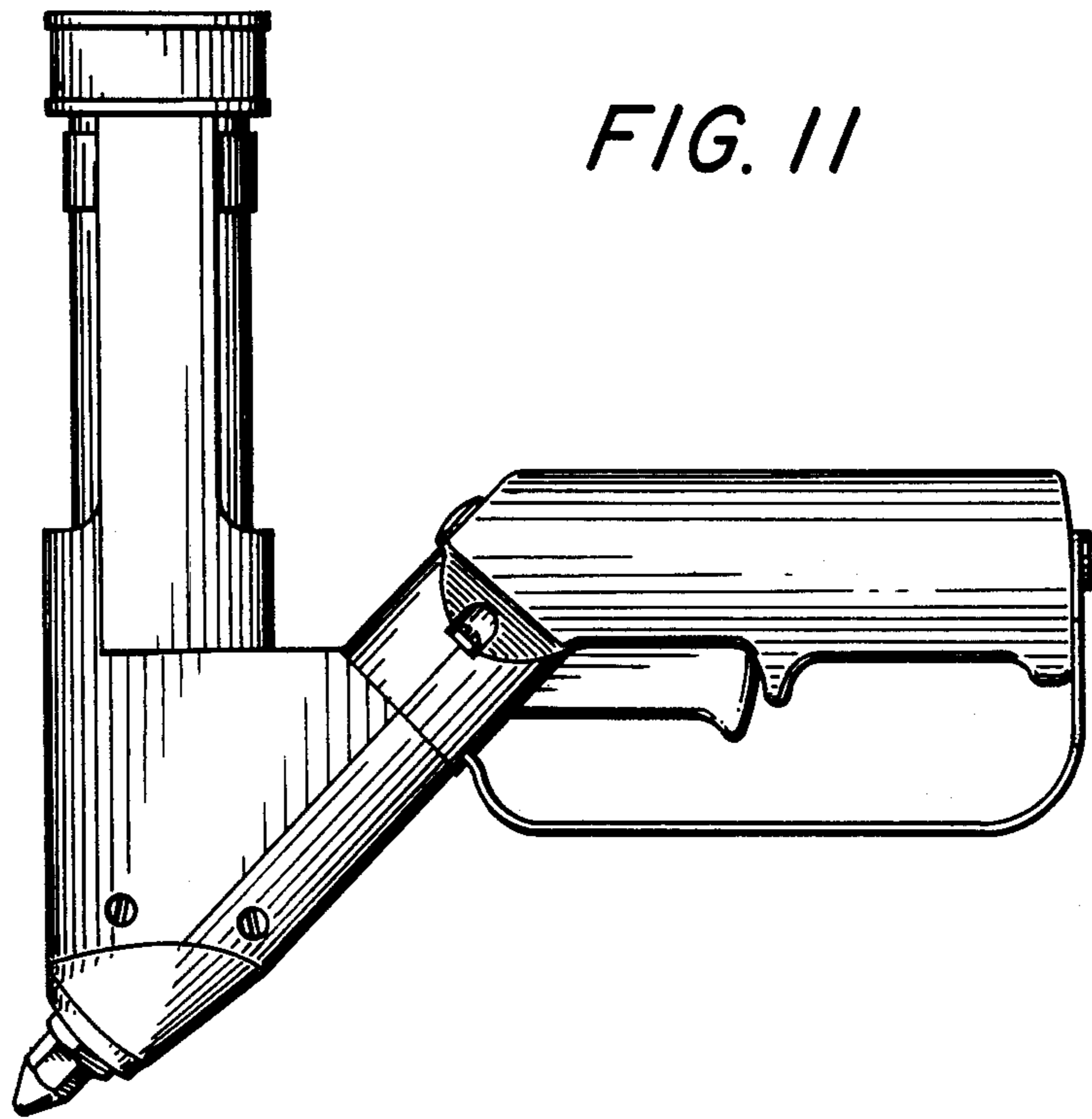

FIG. 11

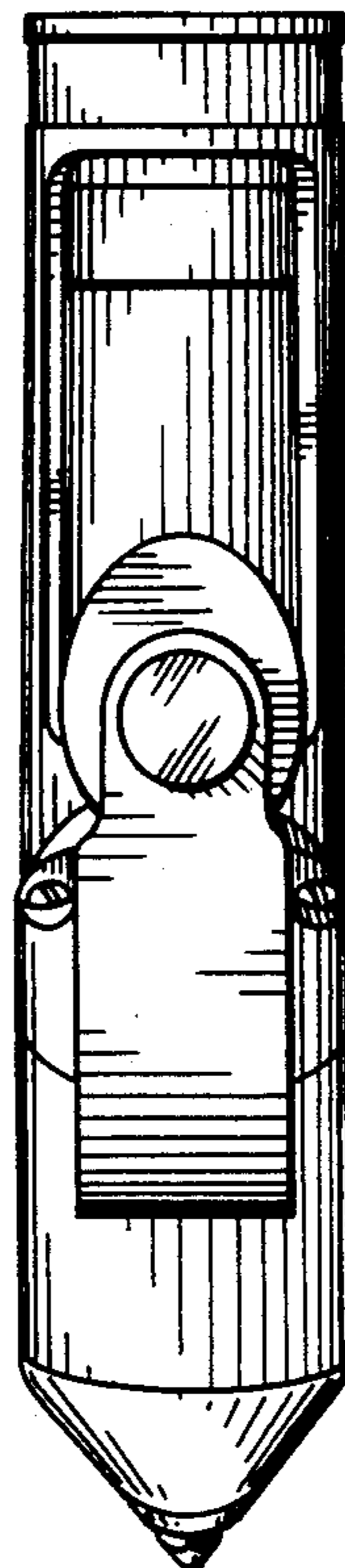

FIG. 12