

[54] **WHEELED PADDLE FOR USE IN FURNACE HEAT TREATING OF ARTICLES**

[75] Inventor: **John Kudla**, Colonia, N.J.

[73] Assignee: **Codi Corporation**, Fair Lawn, N.J.

[**] Term: **14 Years**

[21] Appl. No.: **665,517**

[22] Filed: **Mar. 10, 1976**

[51] Int. Cl. **D23-99**

[52] U.S. Cl. **D23/167**

[58] Field of Search 280/11.1 BT, 11.1 BR;
272/97; D23/167

[56] **References Cited**

U.S. PATENT DOCUMENTS

2,253,012	8/1941	Benner et al.	280/11.1 BT
3,622,172	11/1971	Goodwin	272/97 X
3,827,706	8/1974	Milliman	280/11.1 BT

Primary Examiner—Wallace R. Burke
Assistant Examiner—Larry Jones

Attorney, Agent, or Firm—Harvey W. Mortimer

[57] **CLAIM**

The ornamental design for a wheeled paddle for use in furnace heat treating of articles, as shown and described.

DESCRIPTION

FIG. 1 is a perspective view of a wheeled paddle for use in furnace heat treating of articles incorporating the invention;

FIG. 2 is an end view of a wheeled paddle for use in furnace heat treating of articles incorporating the invention;

FIG. 3 is a top view of a wheeled paddle for use in furnace heat treating of articles incorporating the invention;

FIG. 4 is a side view of a wheeled paddle for use in furnace heat treating of articles incorporating the invention the opposite side being the same;

FIG. 5 is a bottom view of a wheeled paddle for use in furnace heat treating of articles incorporating the invention.

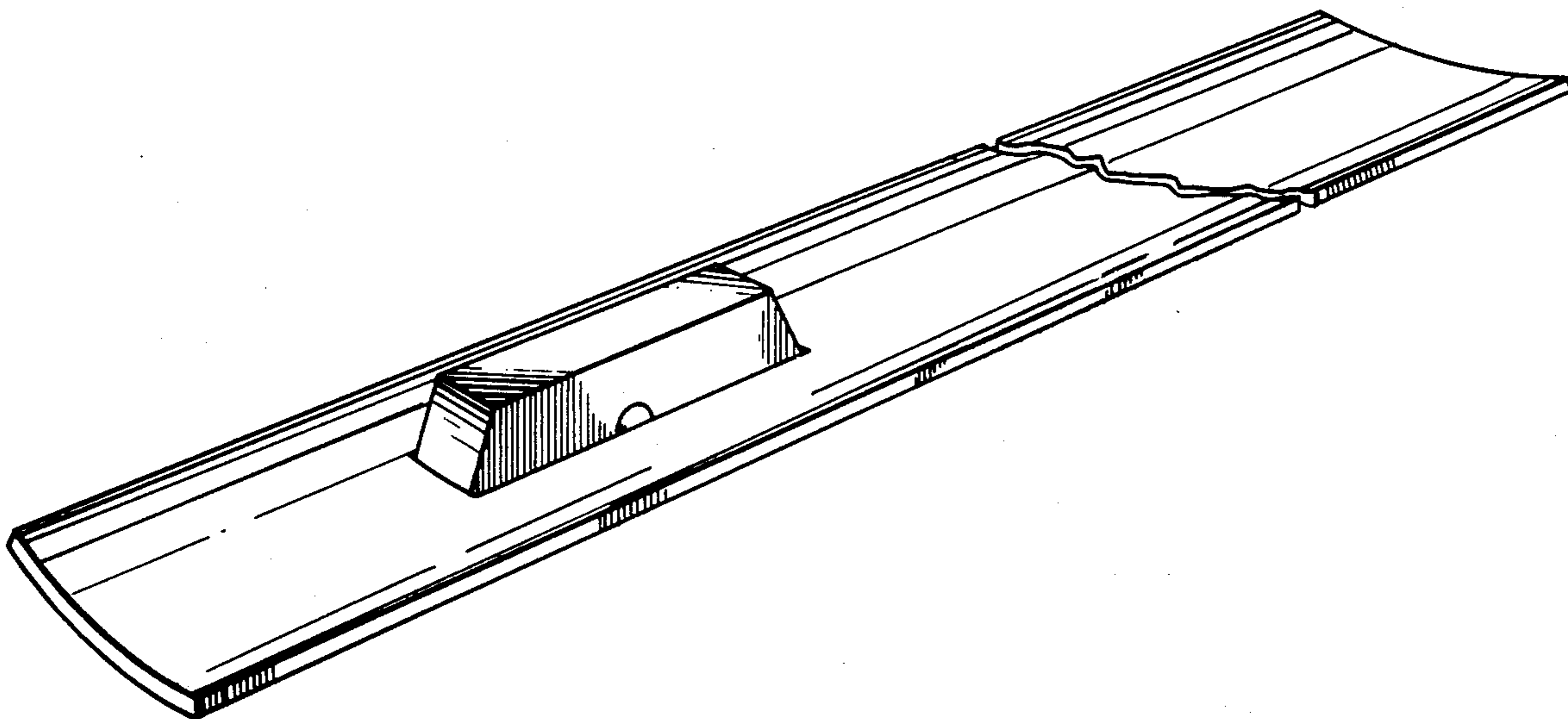

FIG. 1

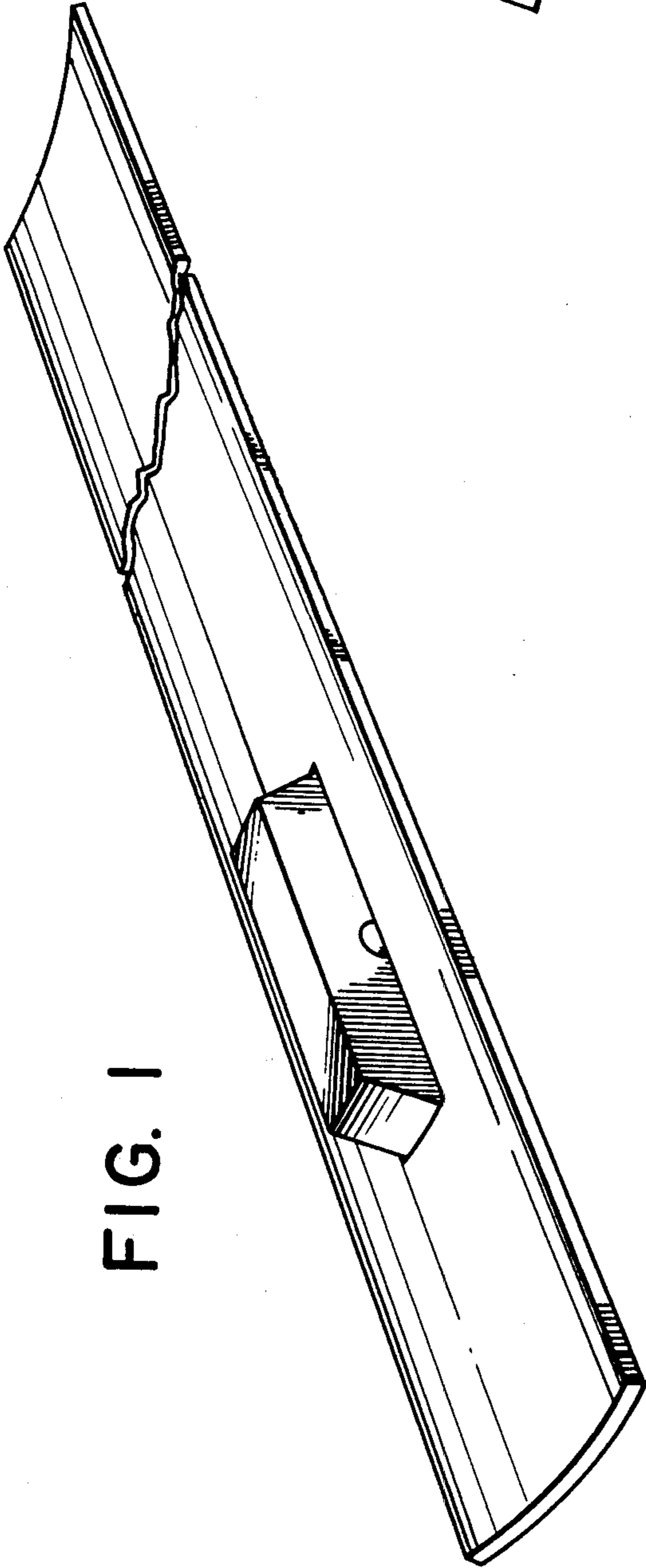

FIG. 2

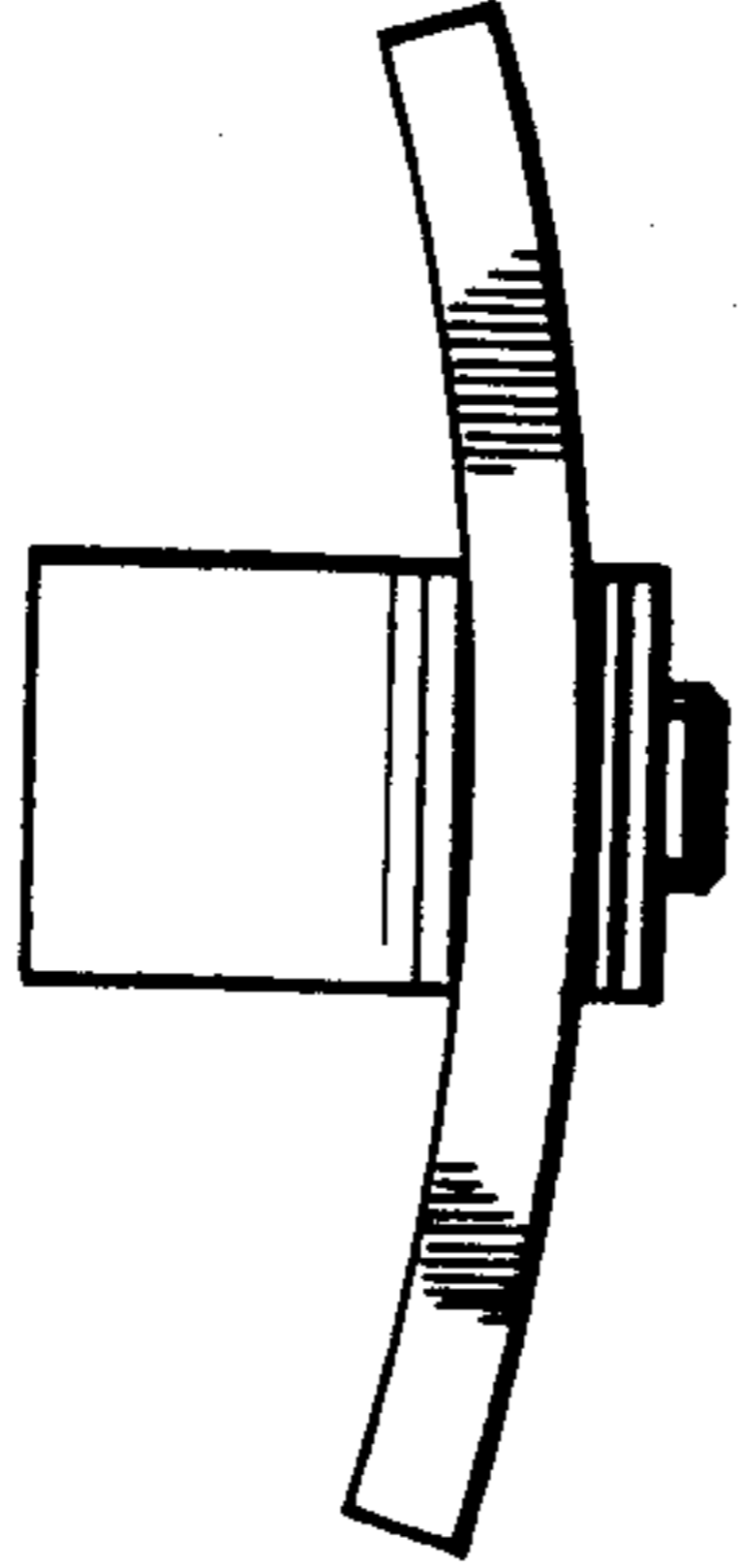

FIG. 3

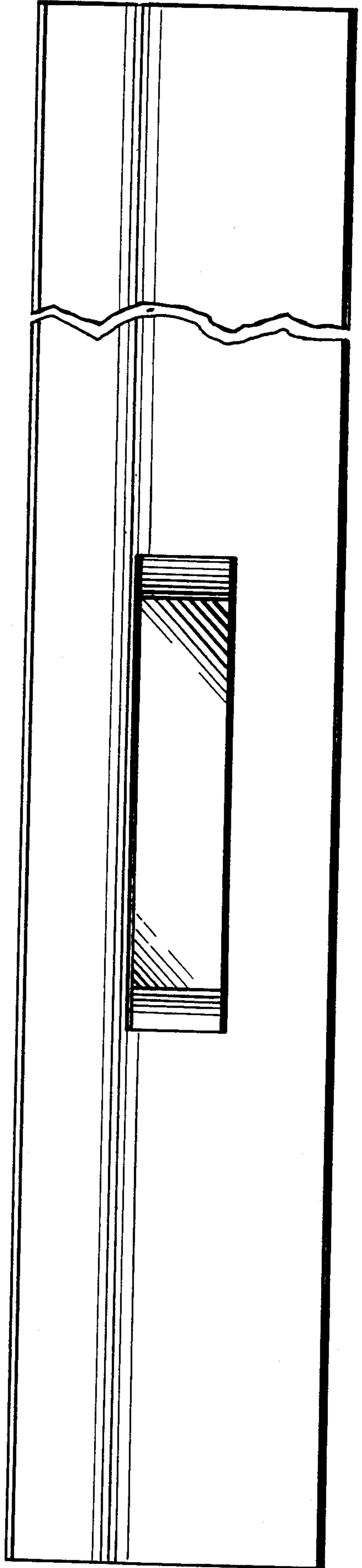

FIG. 4

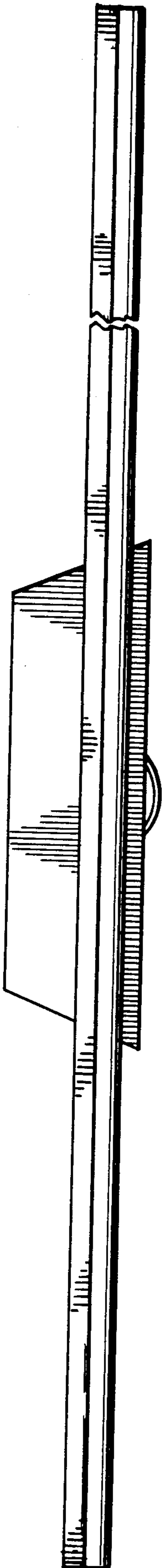

FIG. 5

