

[54] MOTOR GLIDER

[75] Inventors: Kiyoshi Sohda, Yokohama; Hisao Kitada, Yokosuka, both of Japan

[73] Assignee: Japan Aircraft Manufacturing Co., Ltd., Yokohama, Japan

[**] Term: 14 Years

[21] Appl. No.: 733,148

[22] Filed: Oct. 18, 1976

[51] Int. Cl. D12-07

[52] U.S. Cl. D12/71

[58] Field of Search D12/71

[56] References Cited

U.S. PATENT DOCUMENTS

D. 230,961 3/1974 Ryan et al. D12/71

OTHER PUBLICATIONS

The Aircraft of the World, 1965, p. 79, Scheibe SF-24, Motorspatz aircraft at lower left of page.

Primary Examiner—Alan P. Douglas
Attorney, Agent, or Firm—Sidney G. Faber

[57] CLAIM

The ornamental design for a motor-glider, as shown.

DESCRIPTION

FIG. 1 is a top plan view of a motor glider, showing our new design;

FIG. 2 is a front elevational view of the motor glider of FIG. 1;

FIG. 3 is a side elevational view of the motor glider of FIG. 1;

FIG. 4 is a bottom plan view of the motor glider of FIG. 1; and

FIG. 5 is a rear elevational view of the motor glider of FIG. 1.

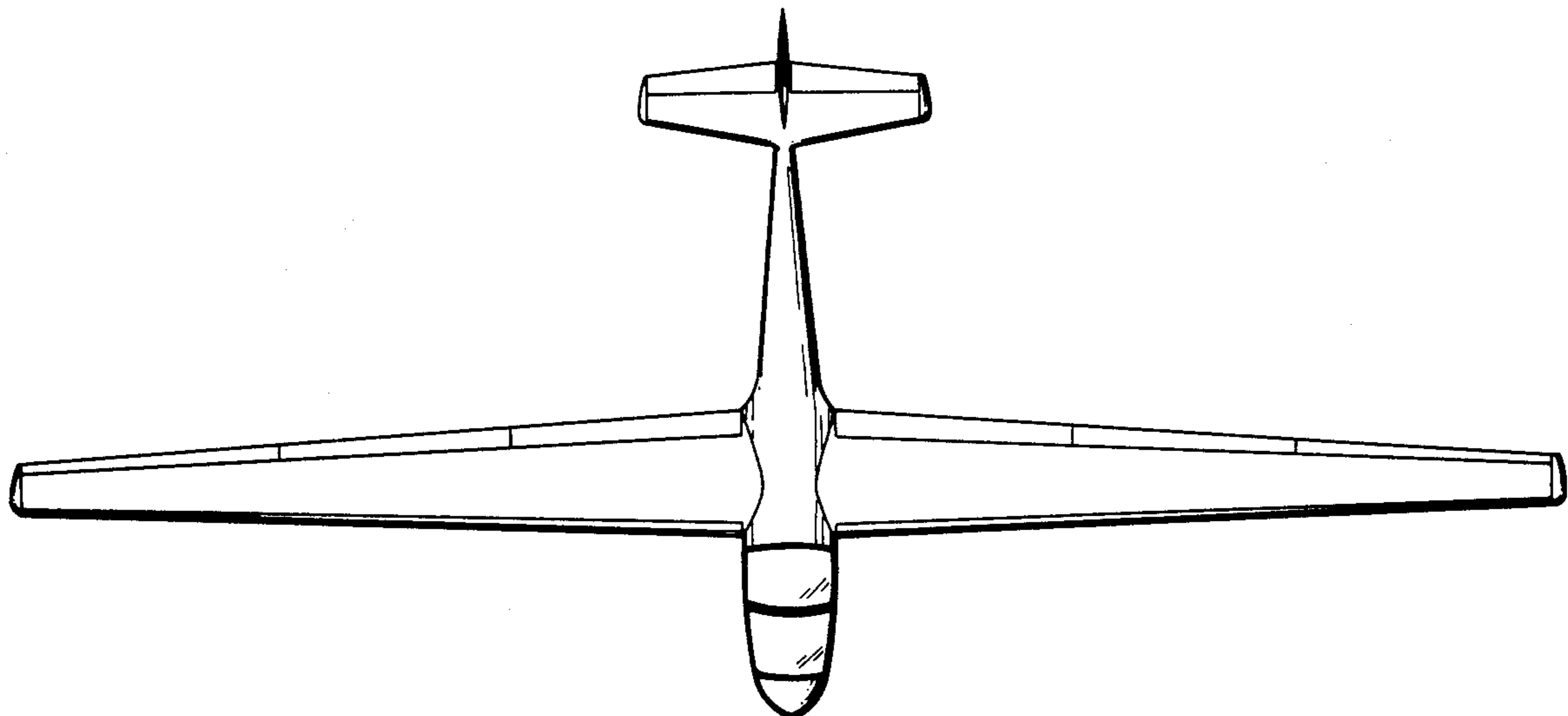
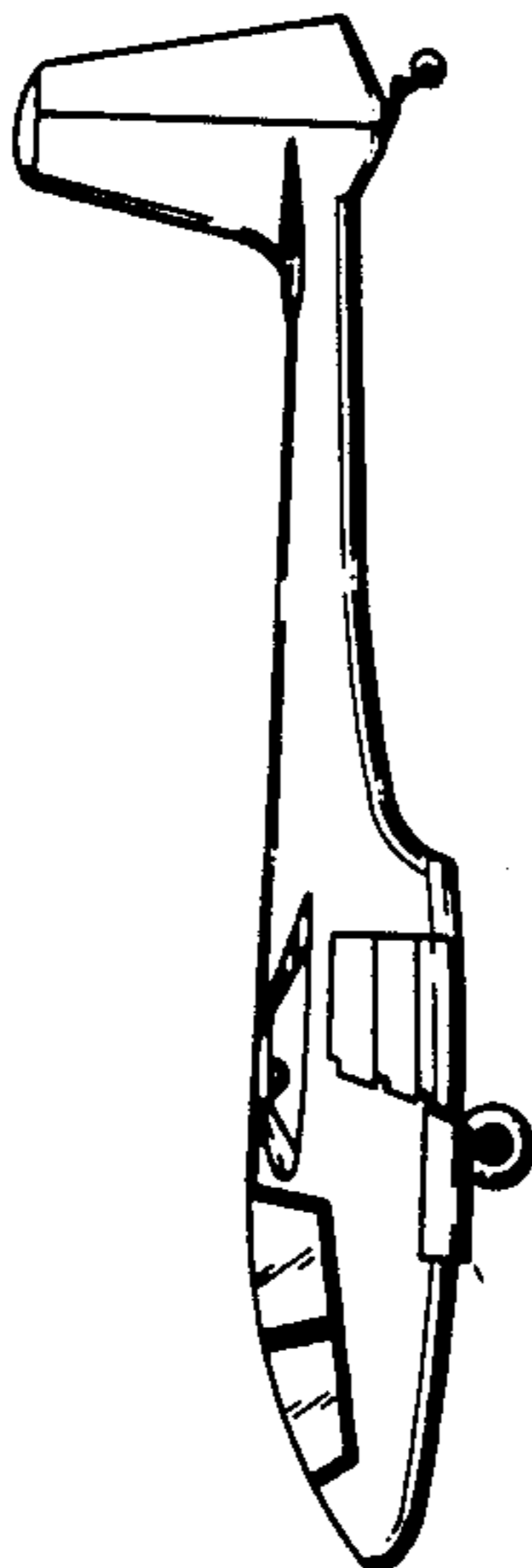

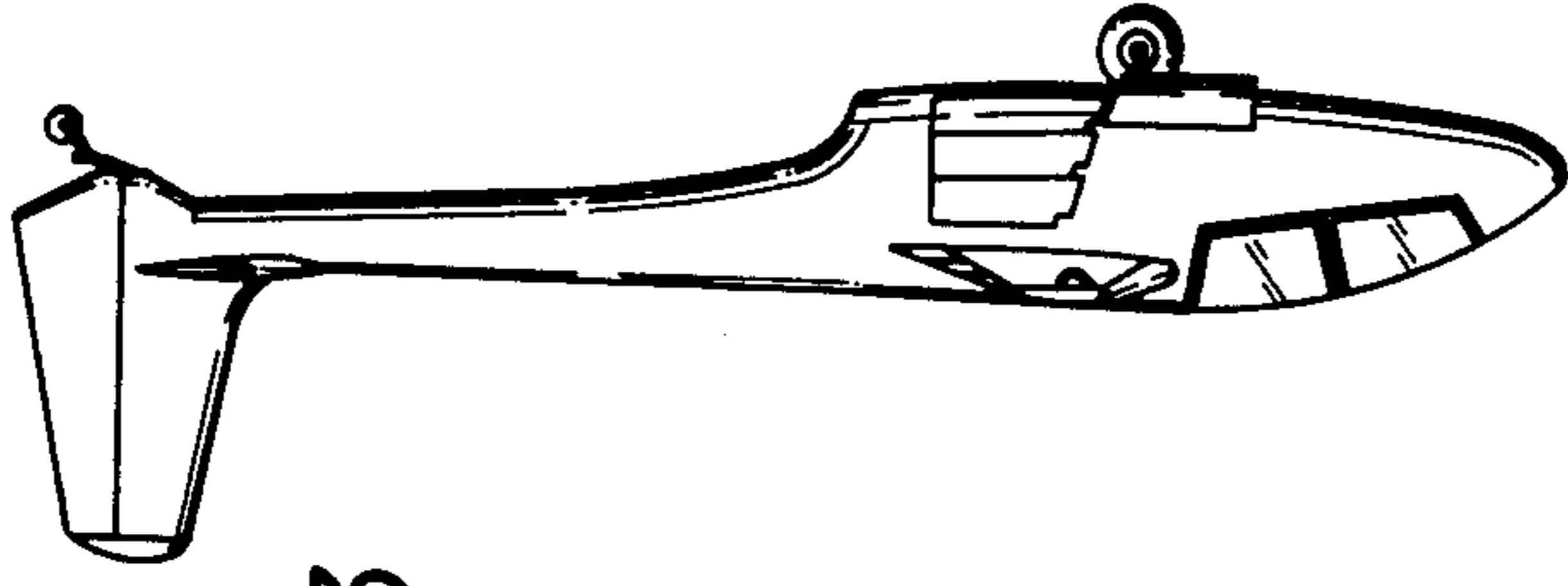

Fig. 3

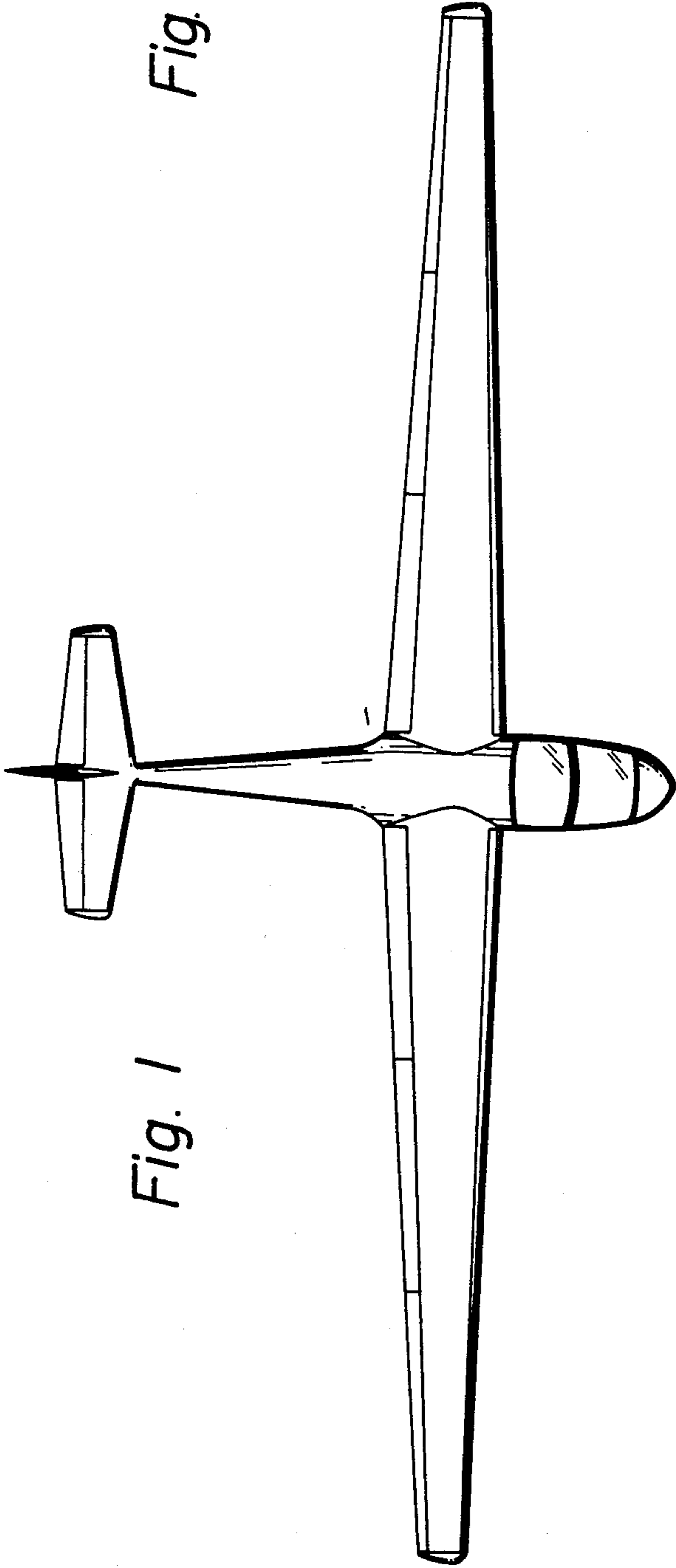

Fig. 1

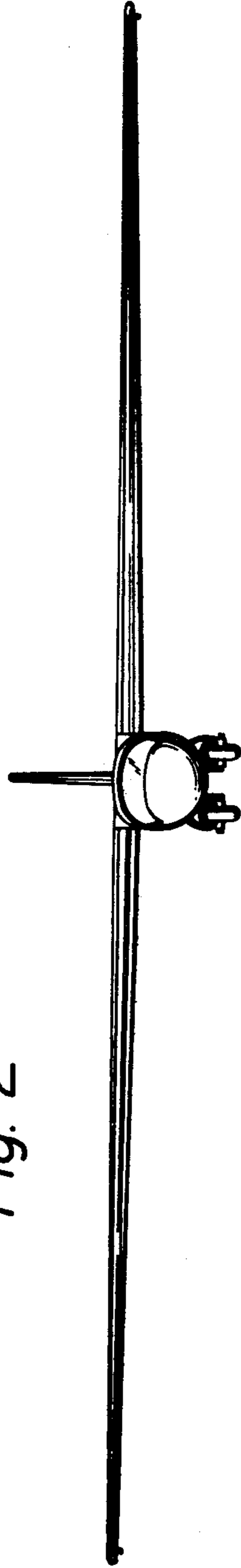

Fig. 2

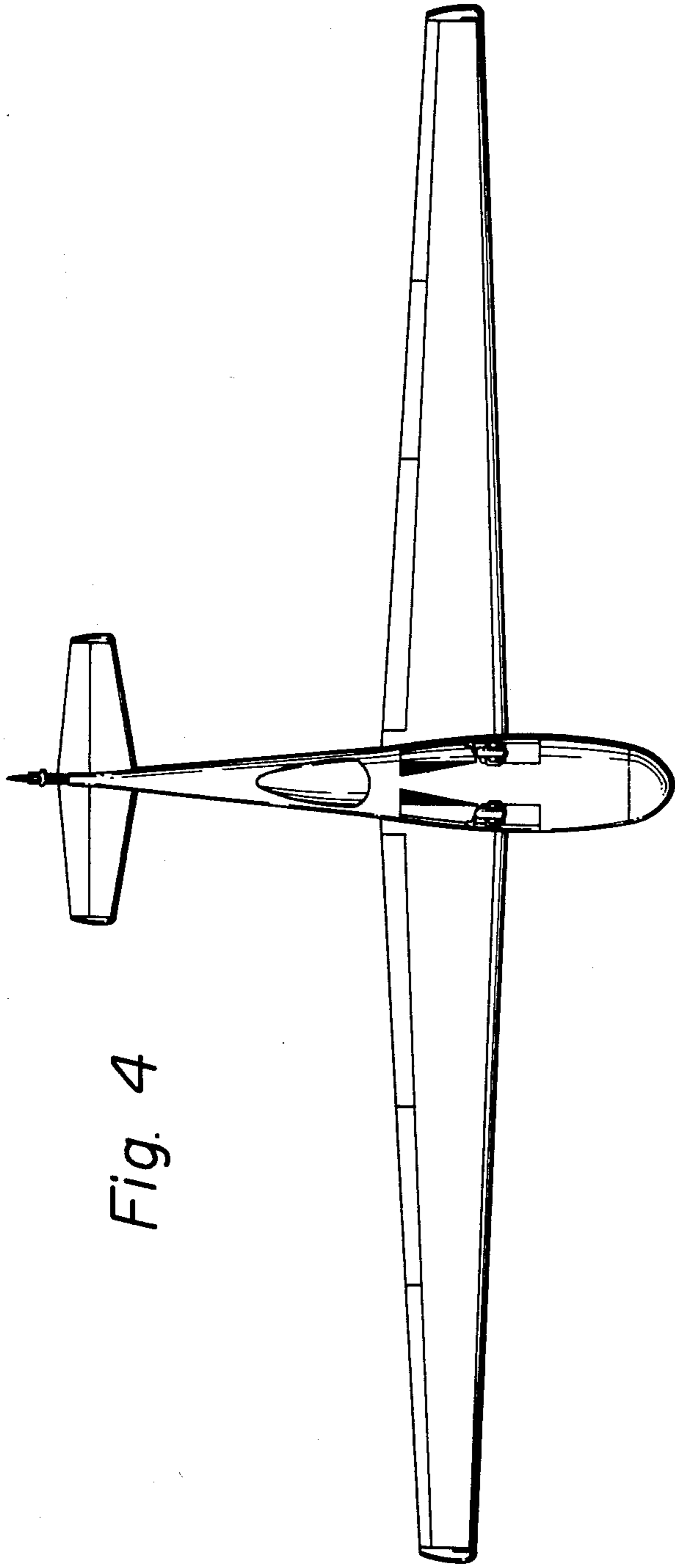

Fig. 4

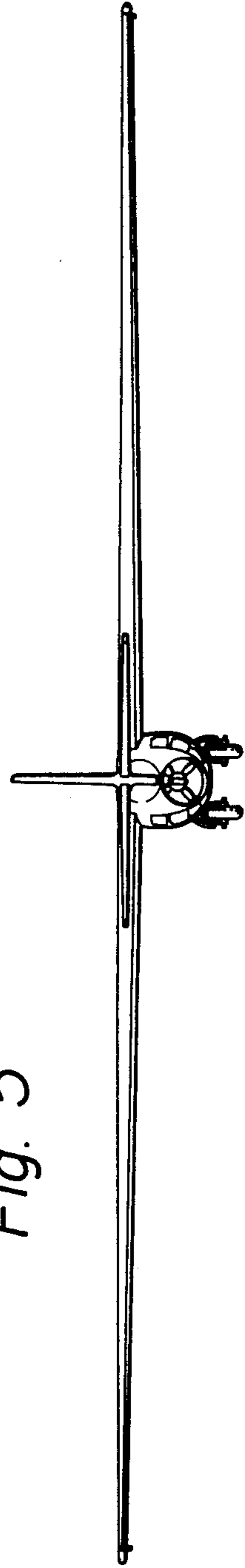

Fig. 5

UNITED STATES PATENT AND TRADEMARK OFFICE
CERTIFICATE OF CORRECTION

PATENT NO. : Des. 245,411
DATED : August 16, 1977
INVENTOR(S) : Sohda et al.

It is certified that error appears in the above-identified patent and that said Letters Patent are hereby corrected as shown below:

On the cover page insert:

--Priority: May 20, 1976
Japan
Sho. 51-18446 --.

Signed and Sealed this

Twenty-seventh Day of February 1979

[SEAL]

Attest:

RUTH C. MASON
Attesting Officer

DONALD W. BANNER
Commissioner of Patents and Trademarks