

[54] BOAT

[75] Inventors: James Bostic, Lansing, Mich.; Schuyler P. Brown, Jr., Treasure Island, Fla.; Emerson Purkapile, Chicago, Ill.

[73] Assignee: Bangor Punta Operations, Inc., Greenwich, Conn.

[**] Term: 14 Years

[21] Appl. No.: 600,039

[22] Filed: July 29, 1975

[51] Int. Cl. D12-06

[52] U.S. Cl. D12/62

[58] Field of Search D12/62

[56] References Cited

U.S. PATENT DOCUMENTS

D. 221,189 7/1971 Engh D12/62

OTHER PUBLICATIONS

Scat-Craft Marine, Inc., boat catalog, rec'd. Feb. 25, 1972, p. 2, SST-165 boat on page.

Glastron Boat Co., catalog No. G-7112, rec'd. Feb. 25, 1972, p. 12, CV-21 boat at bottom of page.

Primary Examiner—Alan P. Douglas
Attorney, Agent, or Firm—Patrick J. Walsh

[57] CLAIM

The ornamental design for a boat, substantially as shown and described.

DESCRIPTION

FIG. 1 is a perspective view showing the boat design; FIG. 2 is another perspective view of the boat; FIG. 3 is a perspective view of the starboard side of the boat; FIG. 4 is a perspective view of the port side of the boat; FIG. 5 is a perspective view of the stern of the boat; FIG. 6 is a perspective view of the bow of the boat; FIG. 7 is a perspective view of the top of the boat; FIG. 8 is a perspective view of the bottom of the boat; FIG. 9 is a perspective view of the stern portion of the boat with the portion of the stern below the rub rail being the same on the other side of the boat. FIG. 10 is an elevation view showing the stern profile from the starboard side of the boat.

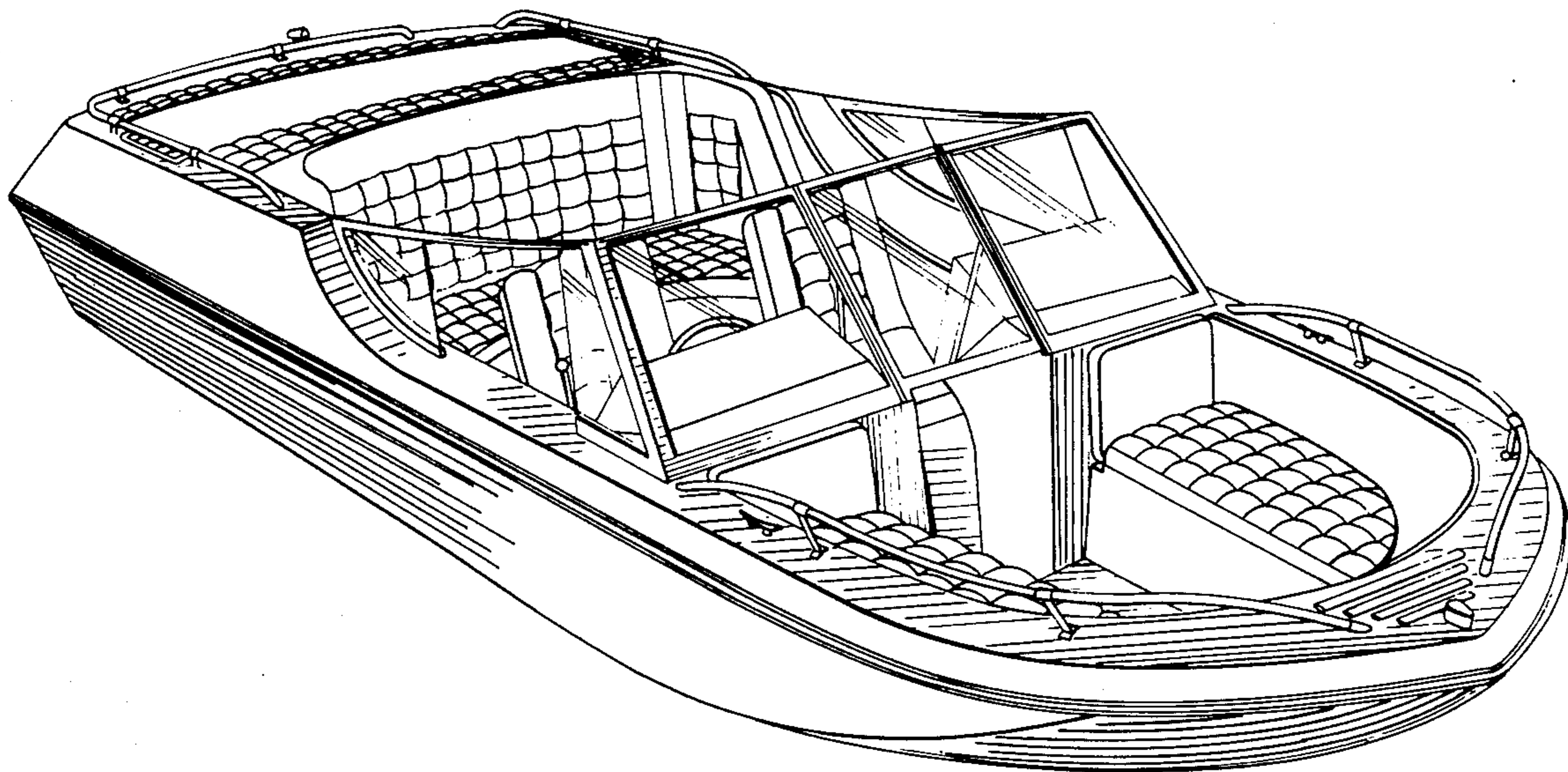

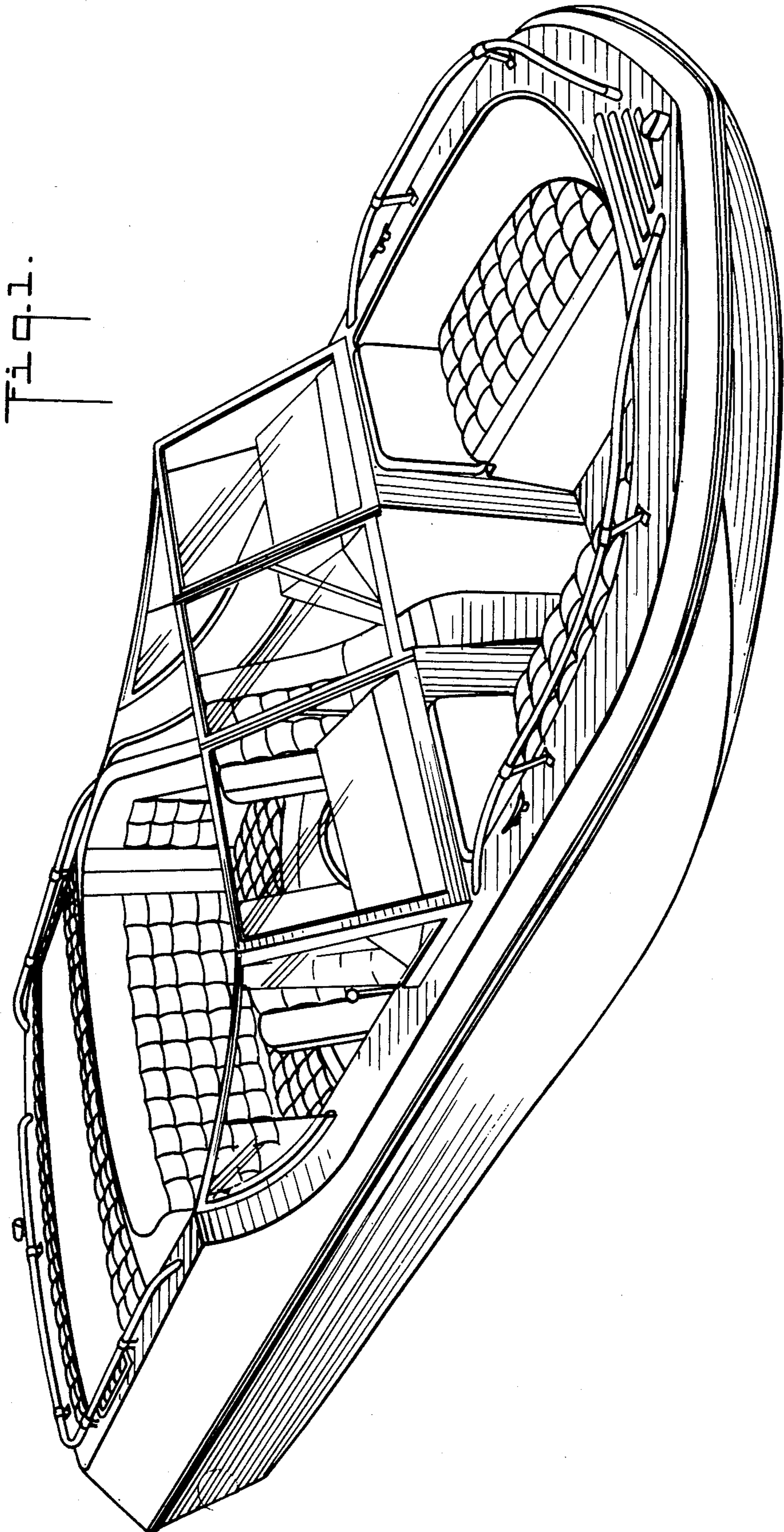

Fig. 2.

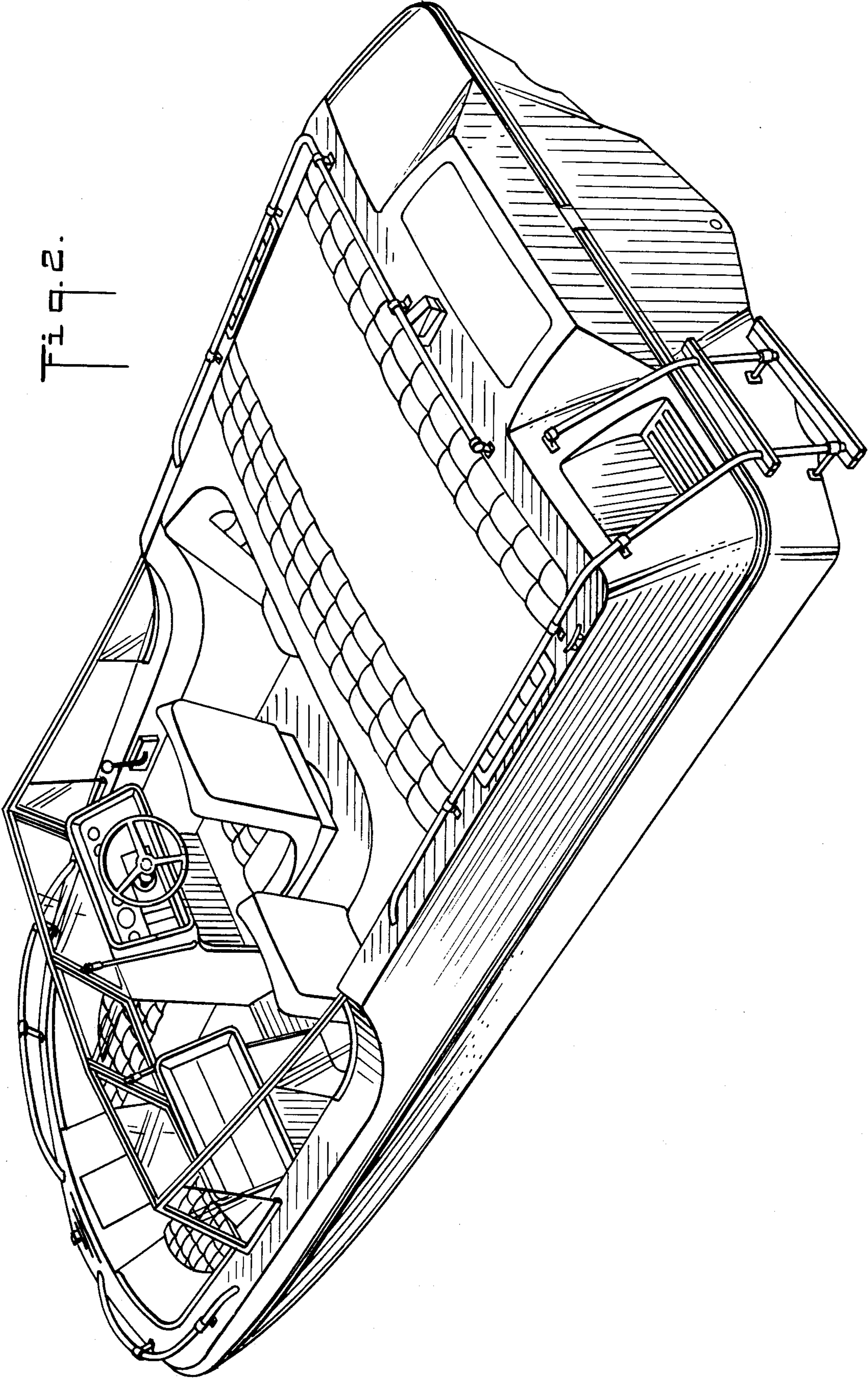

Fig. 3.

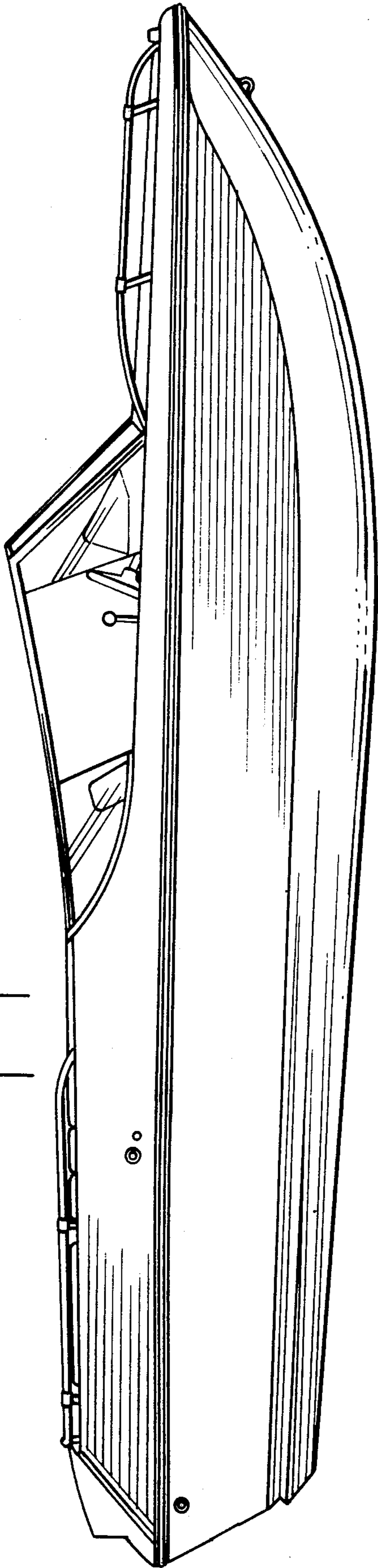
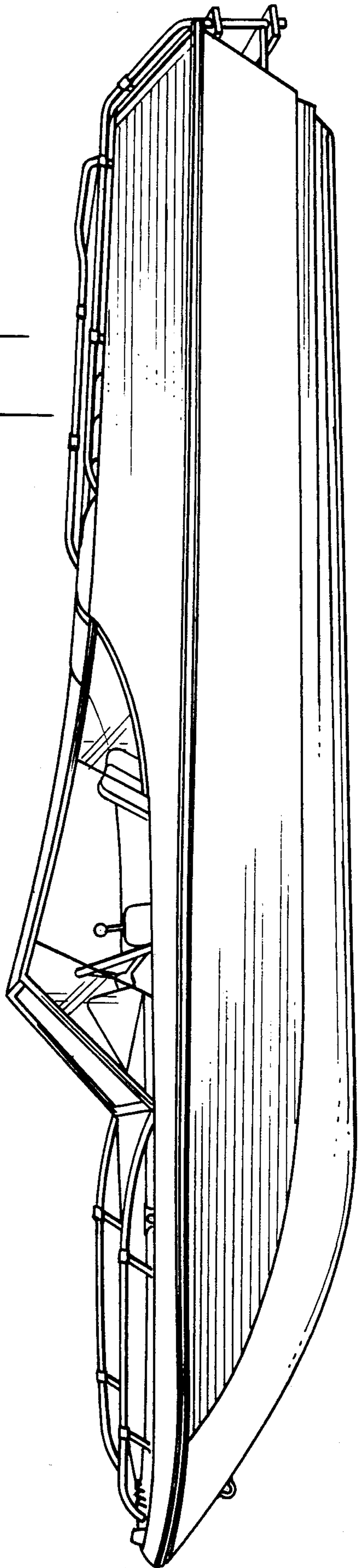

Fig. 4.



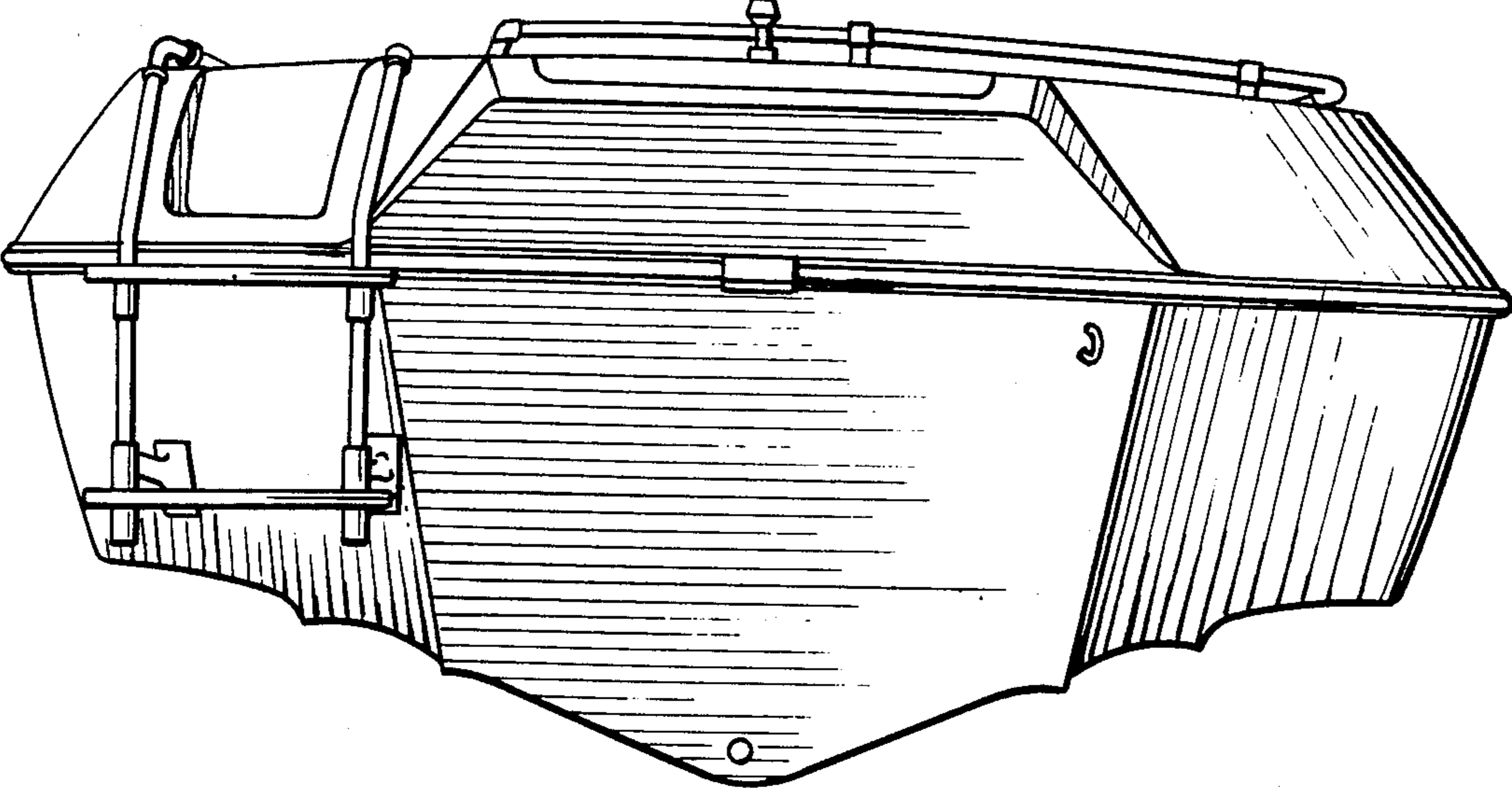
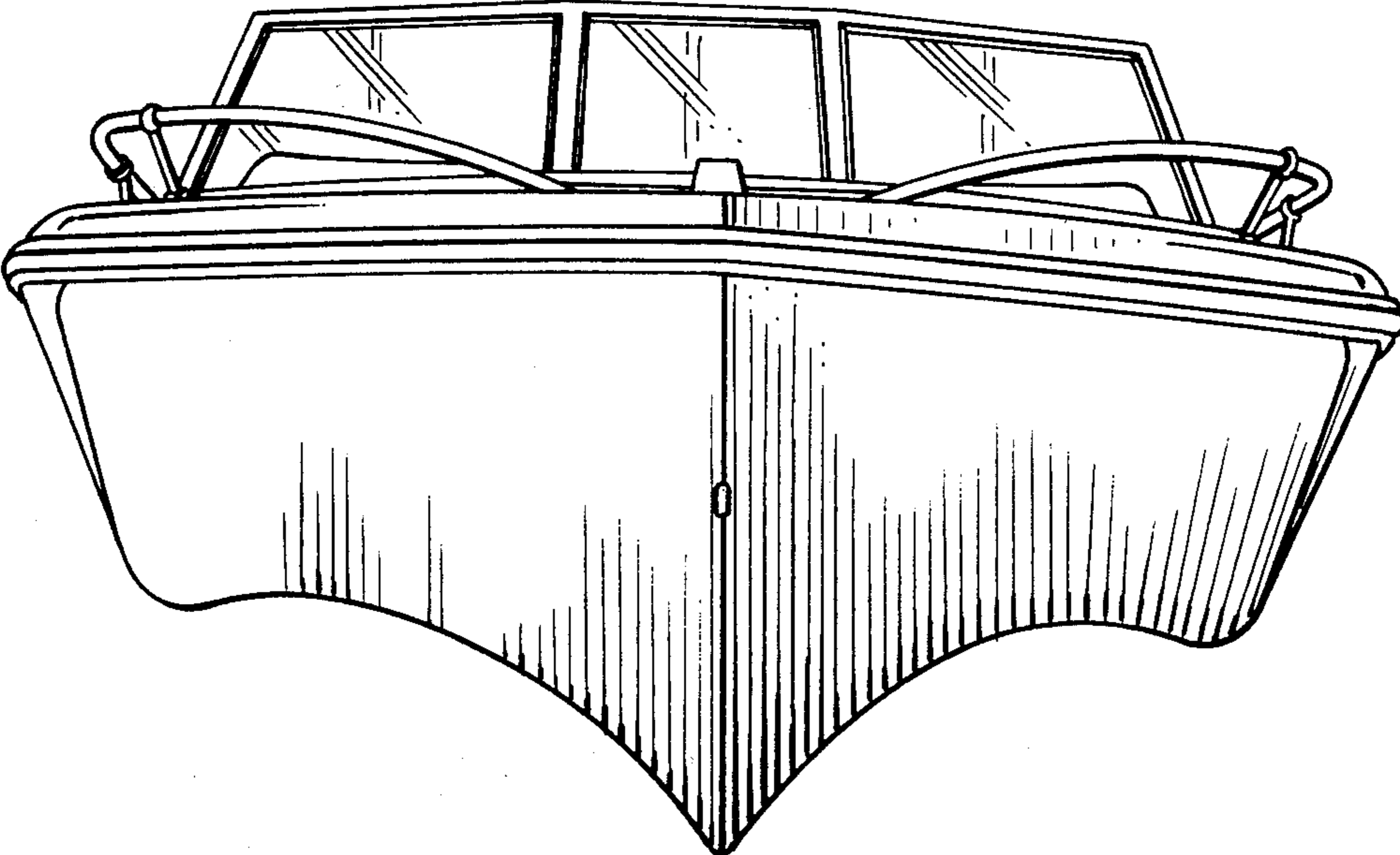

Fig. 5.

Fig. 6.



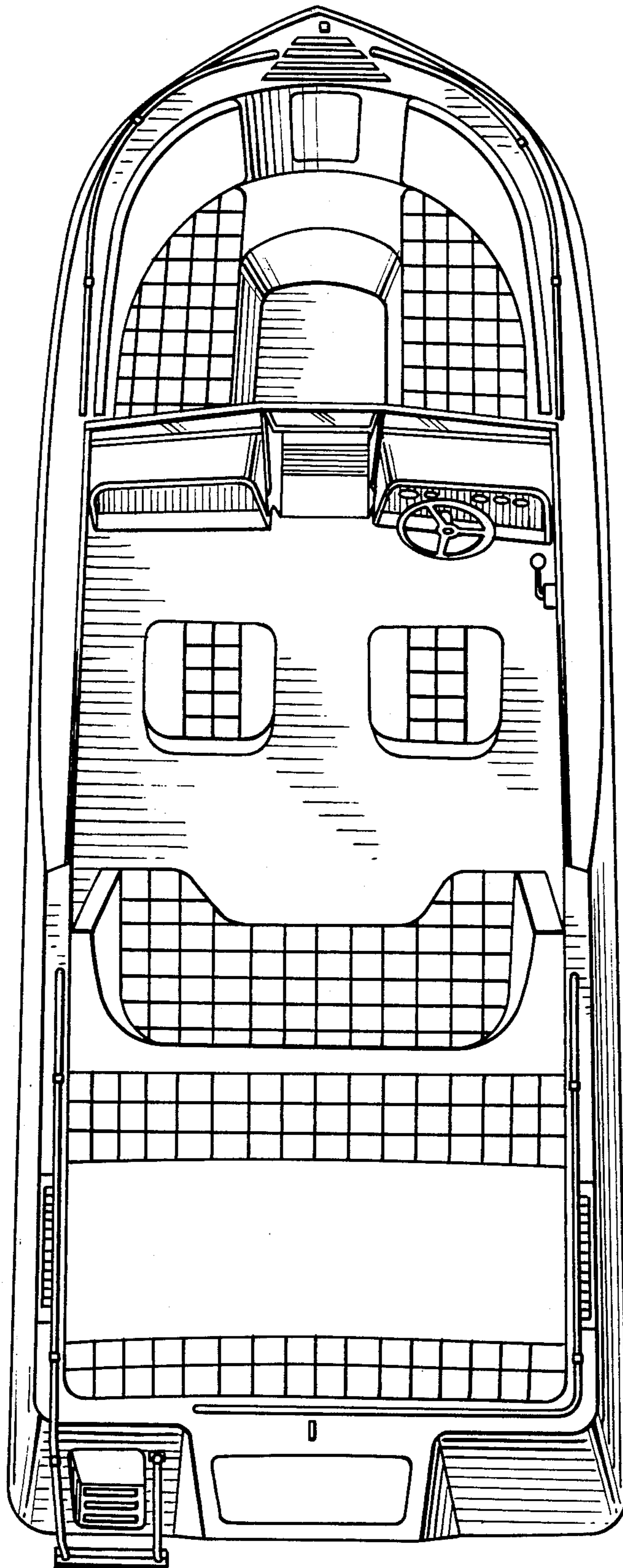

Fig. 2.

Fig. 8.

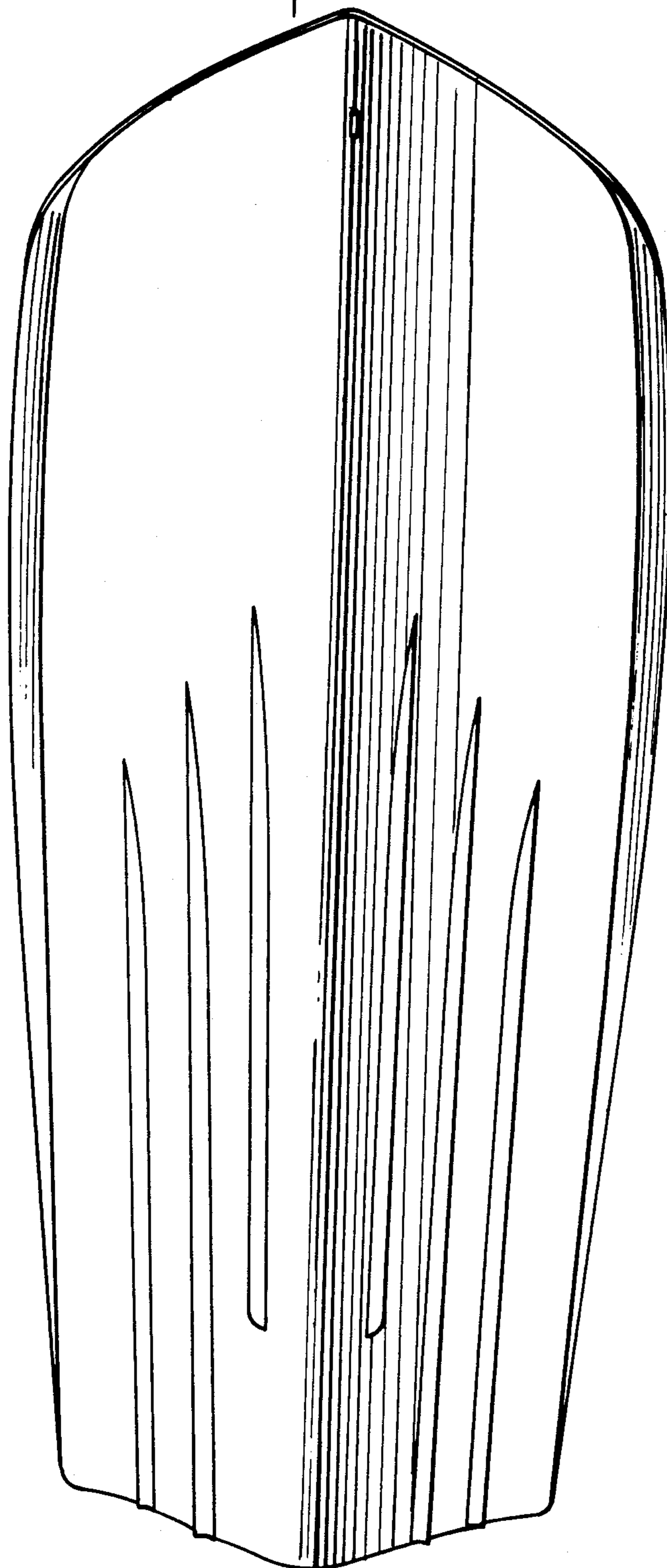

Fig. 9.

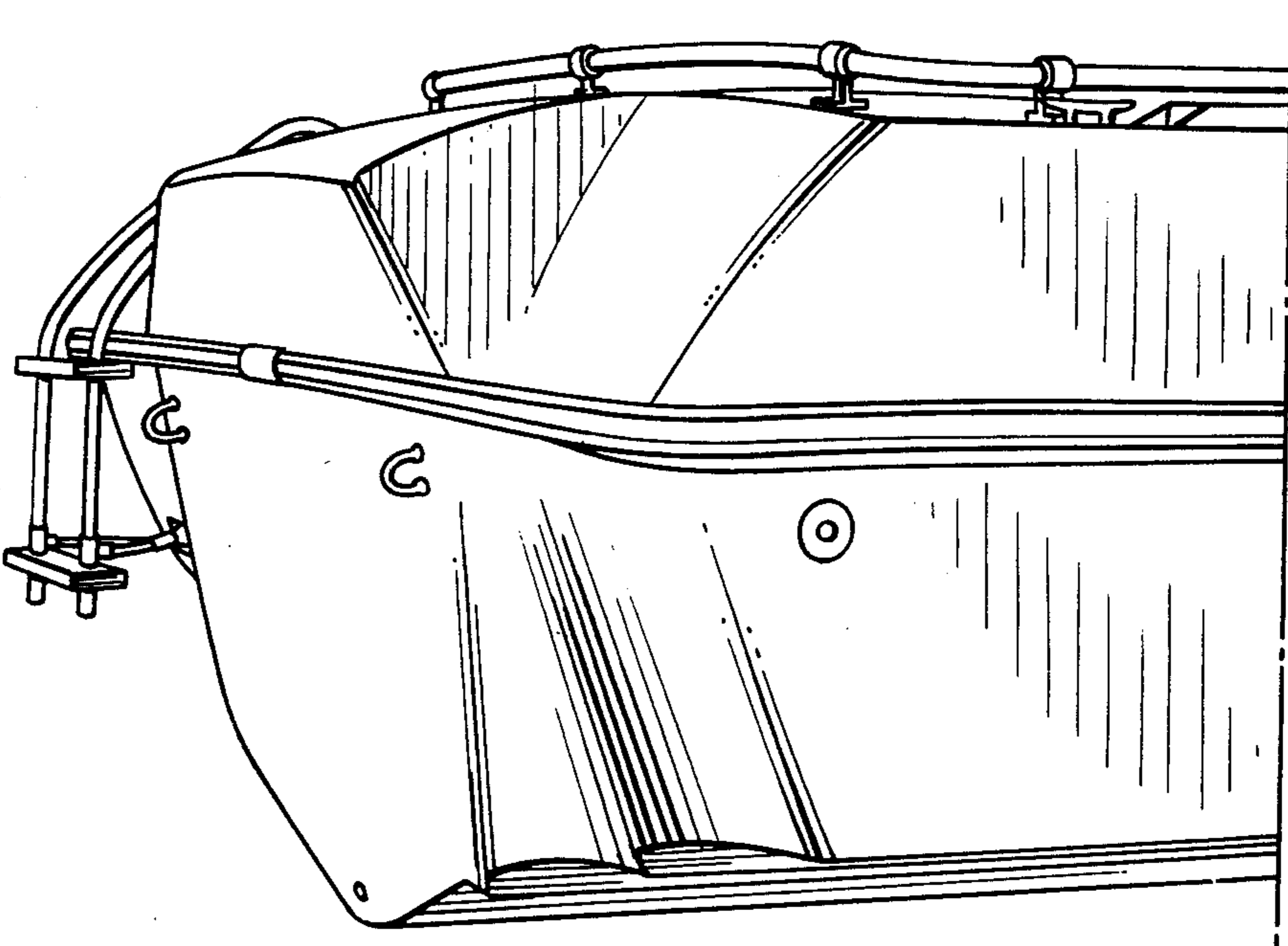

Fig. 10.

