

[54] BRAKE STIRRUP

[75] Inventor: René Lauzier, Ruy, France

[73] Assignee: Angenieux-CLB S.A., Saint-Etienne, France

[**] Term: 14 Years

[21] Appl. No.: 679,865

[22] Filed: Apr. 23, 1976

[30] Foreign Application Priority Data

Nov. 21, 1975 France 75.2142

[51] Int. Cl. D12-11

[52] U.S. Cl. D12/179

[58] Field of Search D12/179, 180; 188/24

[56] References Cited

FOREIGN PATENT DOCUMENTS

2,327,420 12/1974 Germany 188/24

OTHER PUBLICATIONS

American Bicyclist & Motorcyclist, Nov. 1974, p. 60, Brake, top right side of page.

Primary Examiner—Wallace R. Burke
Assistant Examiner—James M. Gandy
Attorney, Agent, or Firm—Irvin S. Thompson

[57] CLAIM

The ornamental design for a brake stirrup, as shown.

DESCRIPTION

FIG. 1 is a front perspective view of a brake stirrup showing my new design;
FIG. 2 is a side elevational view from the near side thereof in FIG. 1;
FIG. 3 is a front elevational view thereof;
FIG. 4 is a side elevational view from the side opposite FIG. 2;
FIG. 5 is a rear elevational view thereof;
FIG. 6 is a top plan view thereof; and
FIG. 7 is a bottom plan view thereof.

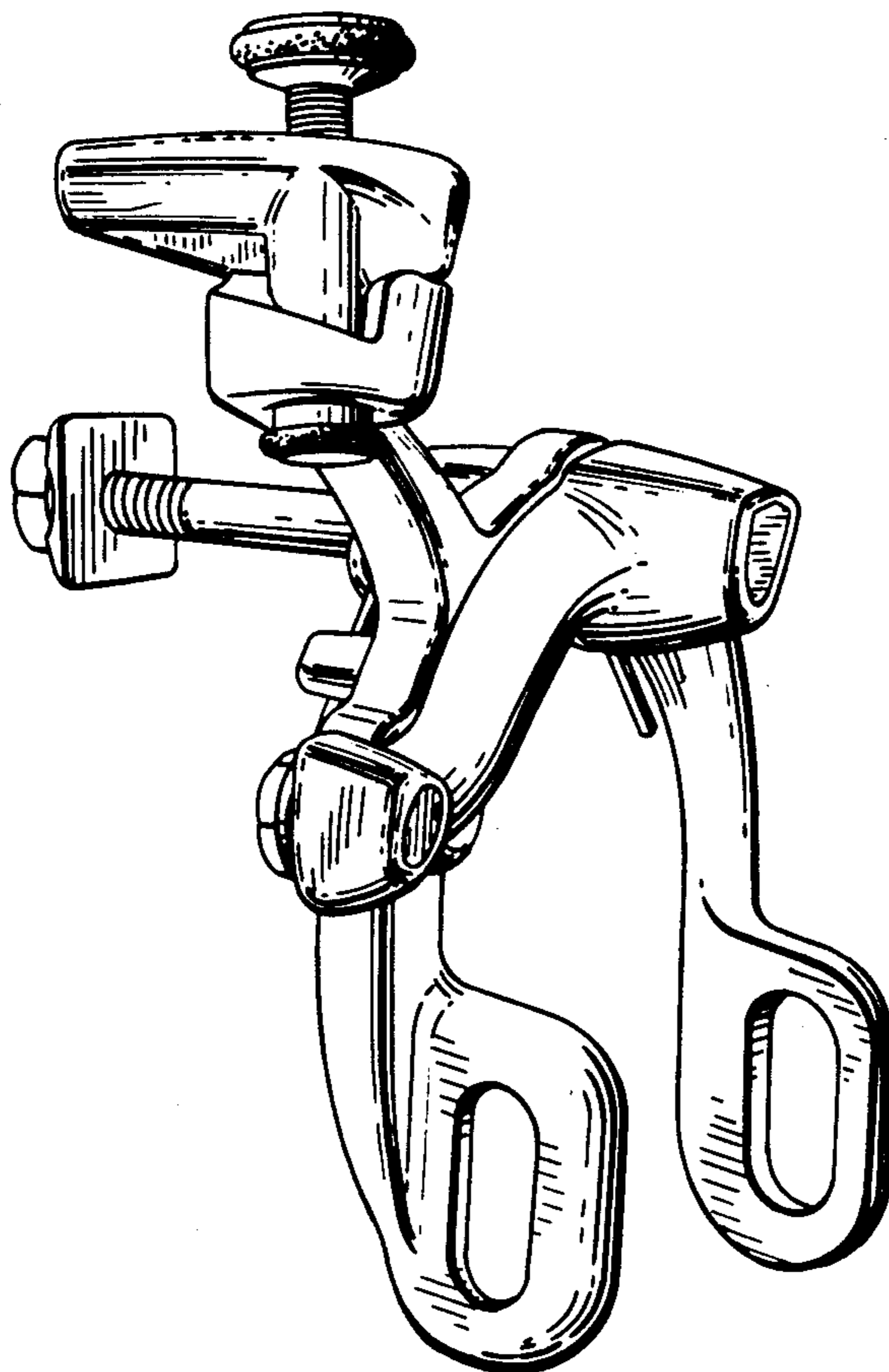

FIG. 1

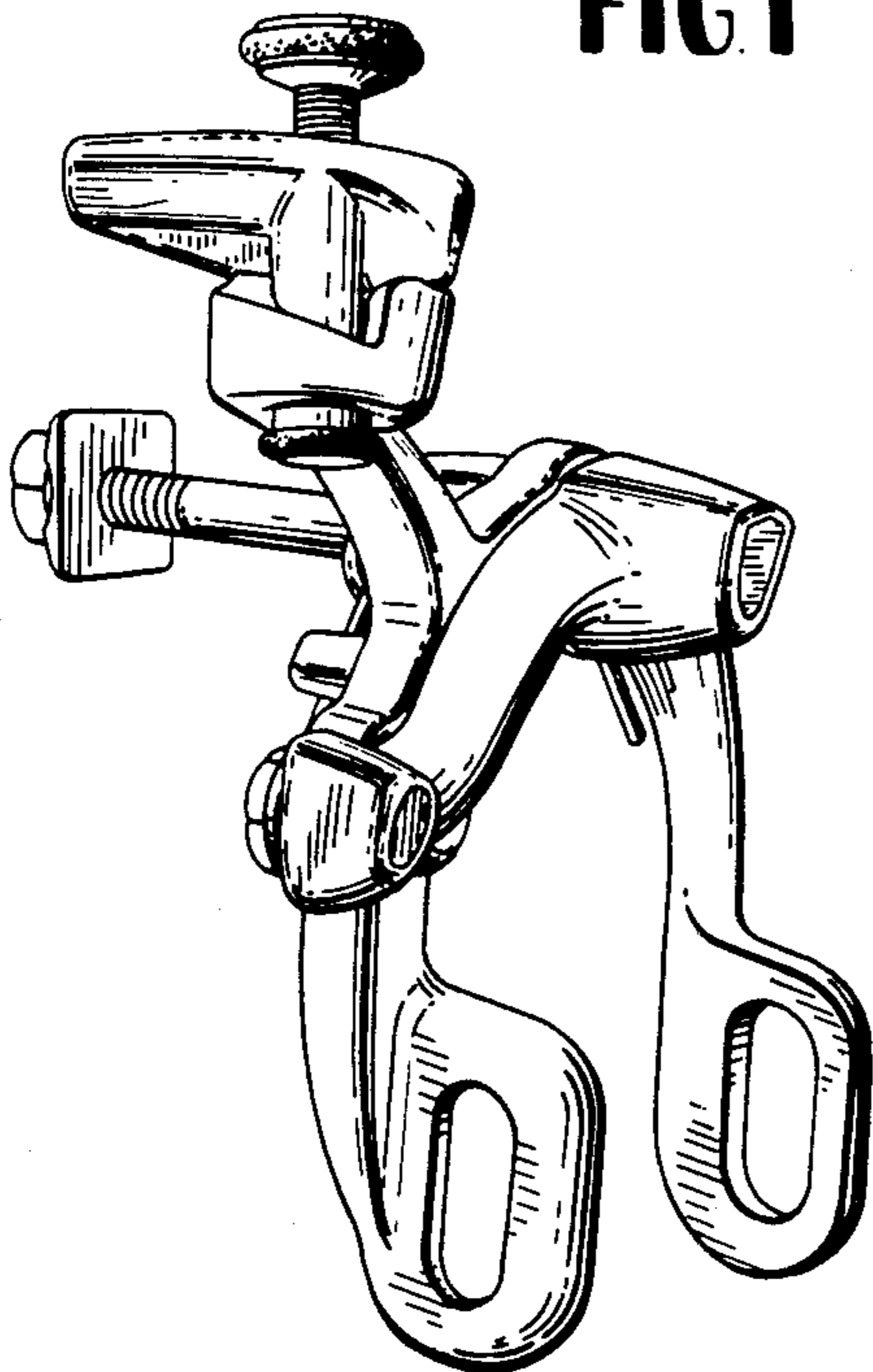

FIG. 2

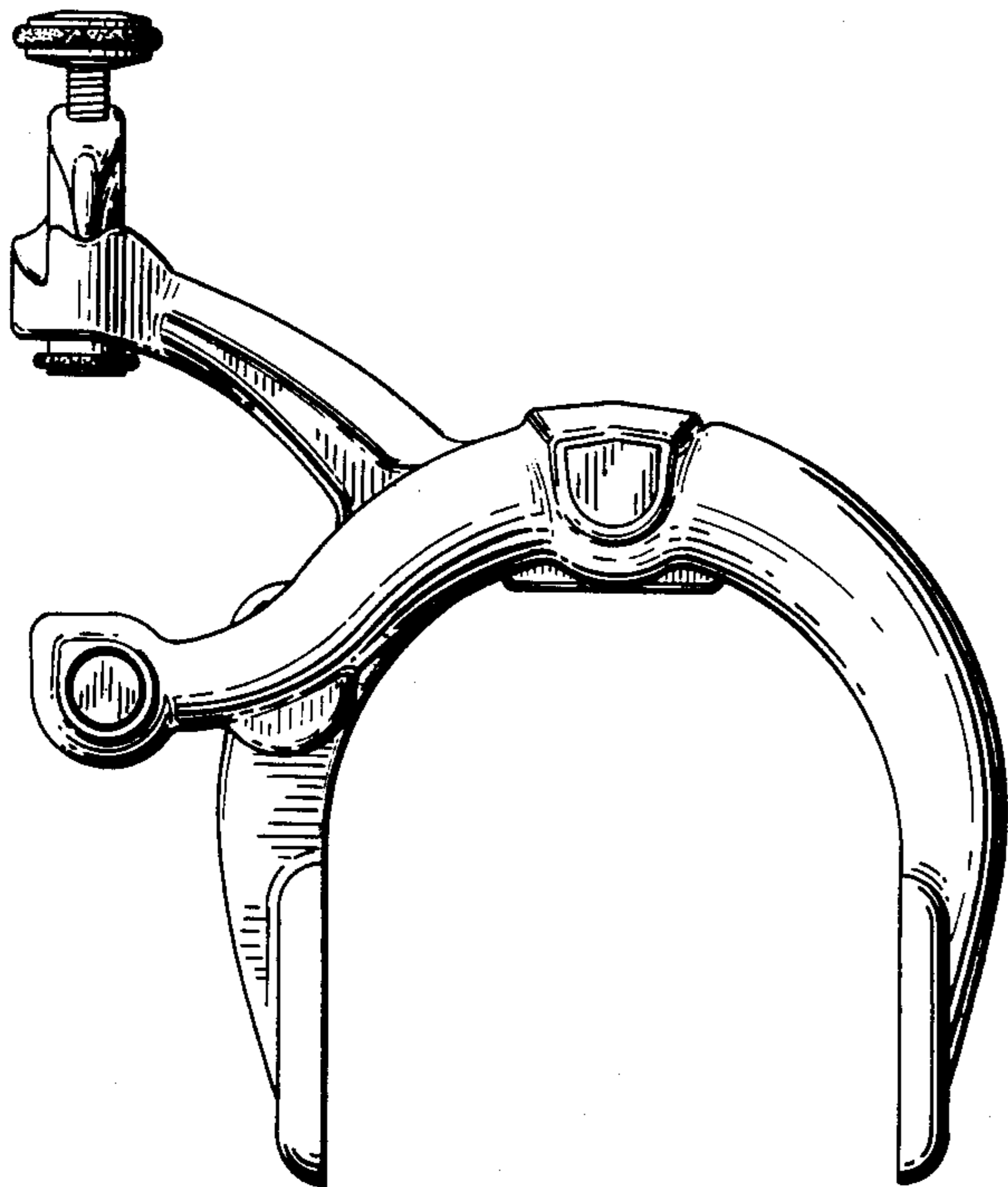
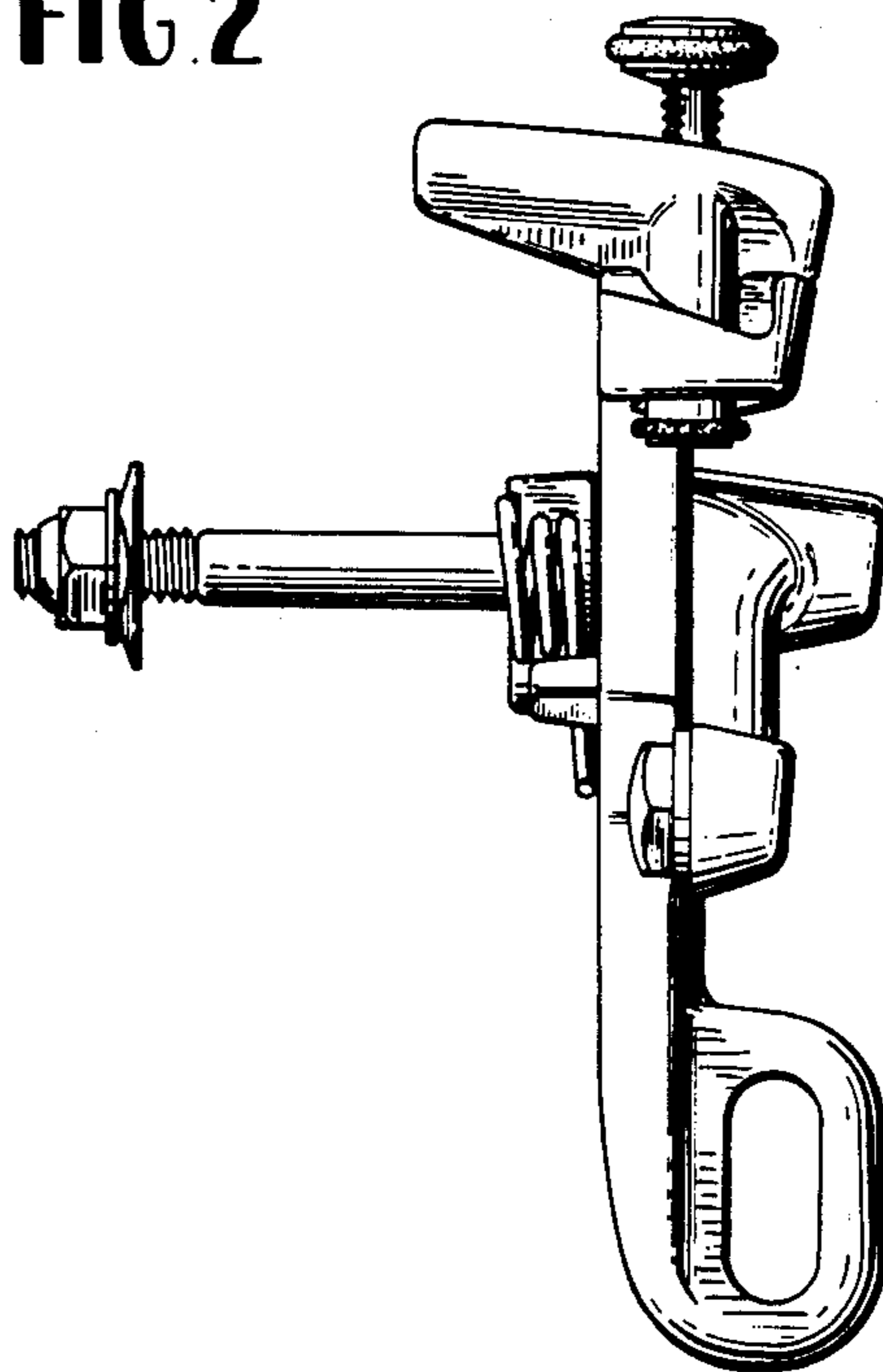

FIG. 3

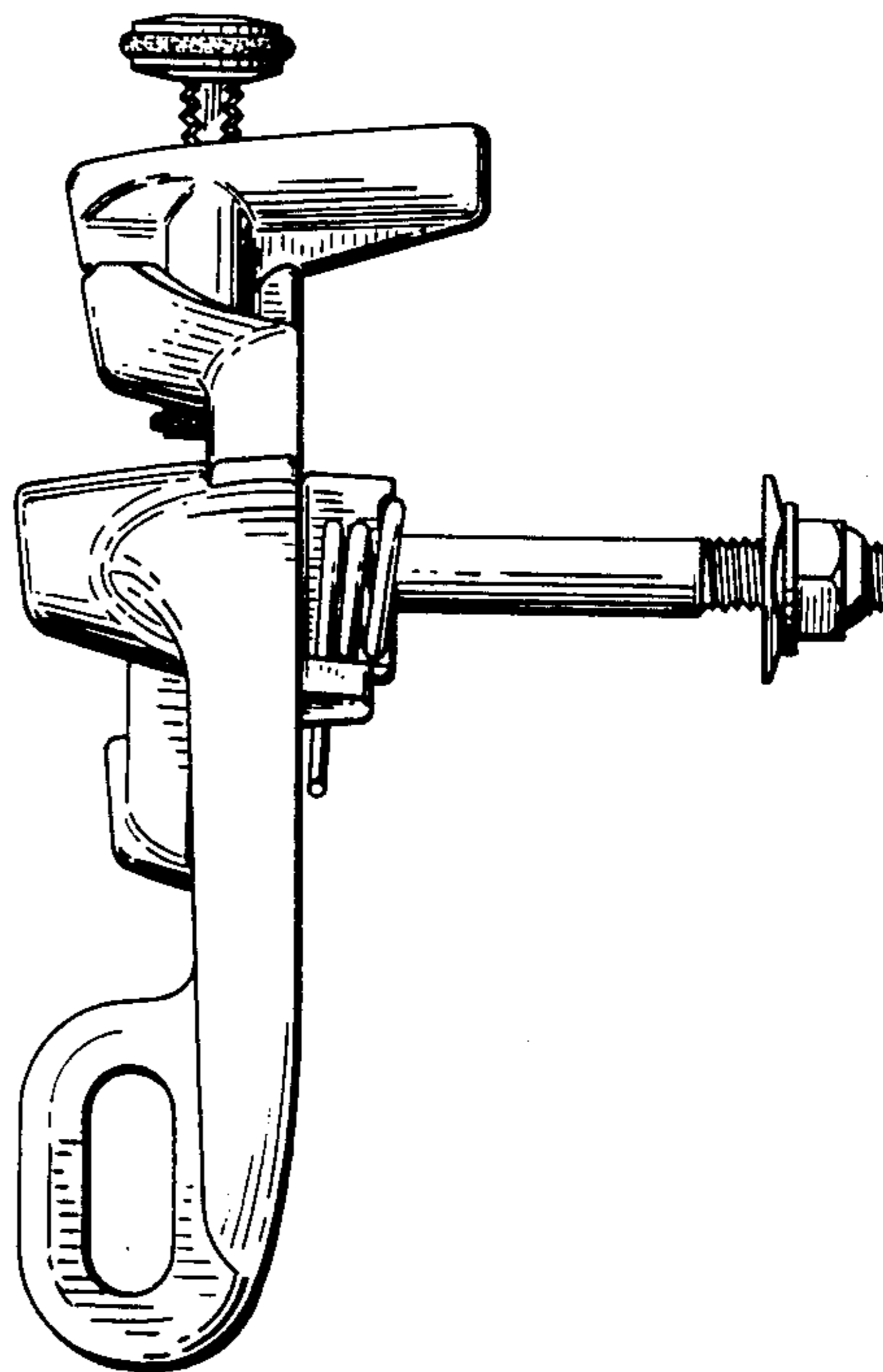

FIG. 4

FIG. 5

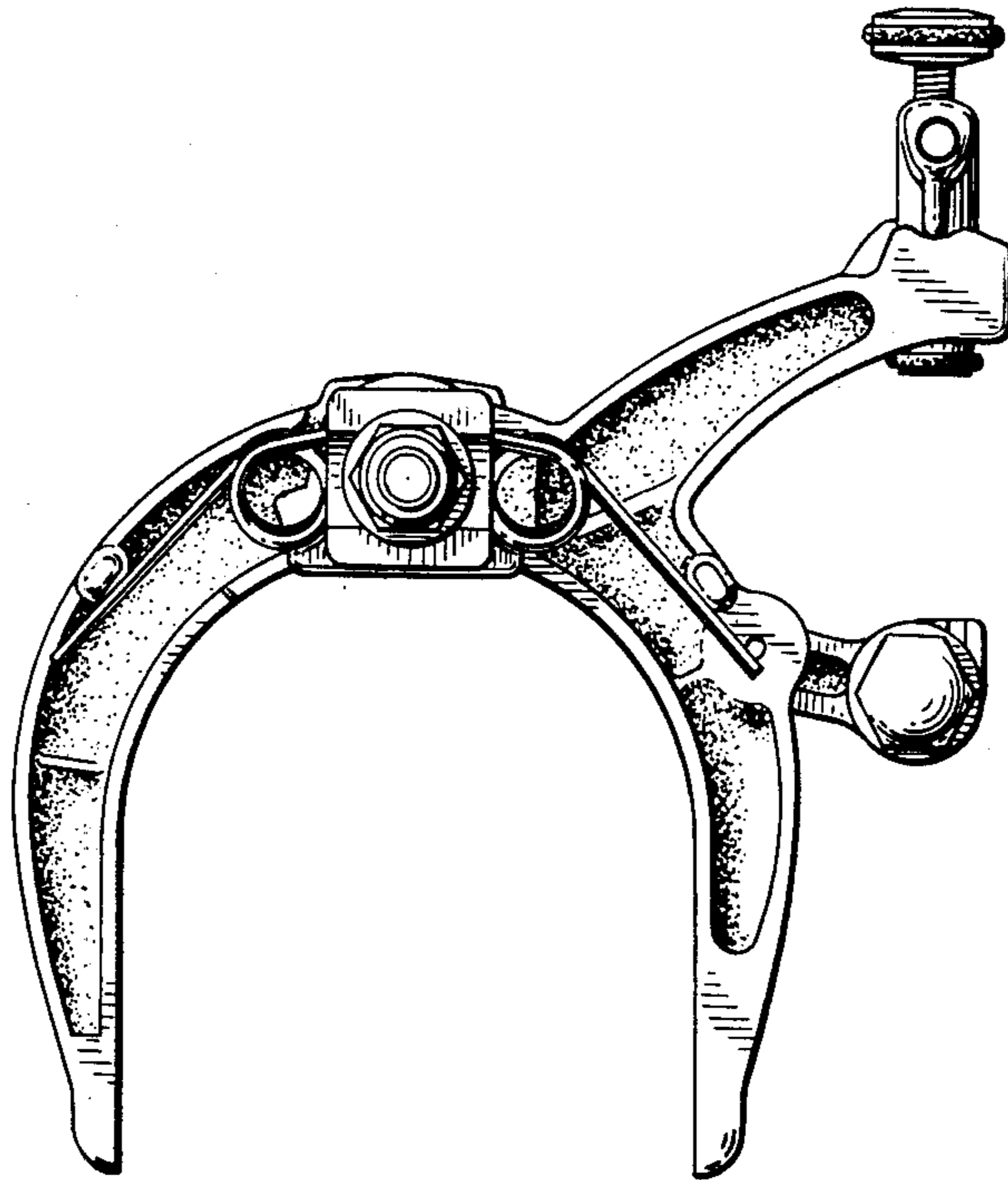

FIG. 6

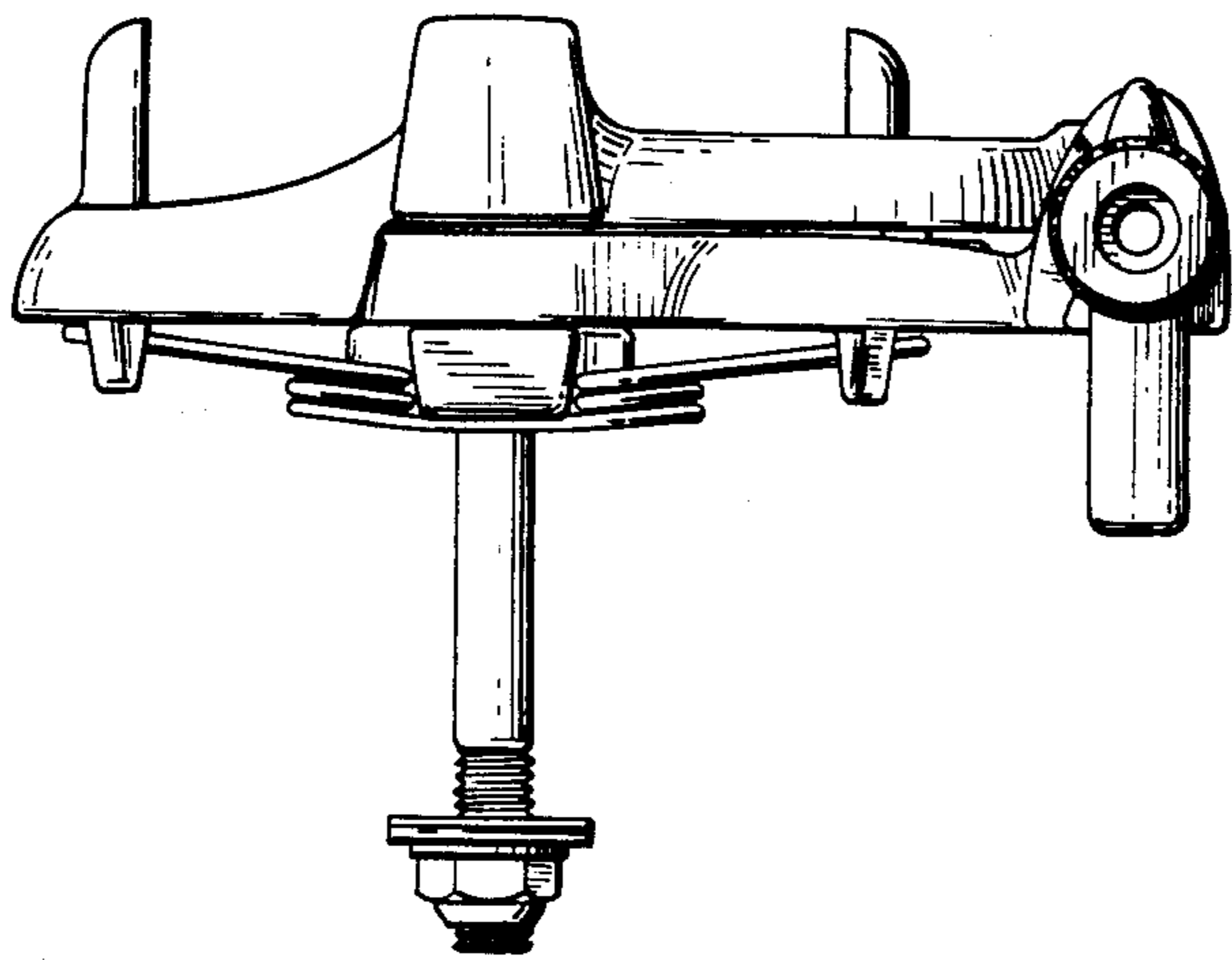

FIG. 7

