

[54] AIRPLANE

[75] Inventor: Gerhard Ernst Seidel, Renton, Wash.

[73] Assignee: The Boeing Company, Seattle, Wash.

[\*\*] Term: 14 Years

[21] Appl. No.: 658,317

[22] Filed: Feb. 17, 1976

**Related U.S. Application Data**

[63] Continuation-in-part of Ser. No. 591,973, June 30, 1975, abandoned.

[51] Int. Cl. .... D12-07

[52] U.S. Cl. .... D12/76

[58] Field of Search ..... D12/76, 80; 244/36, 244/118 R

[56]

**References Cited**

**U.S. PATENT DOCUMENTS**

3,869,102	3/1975	Carroll .....	244/36
D. 199,510	11/1964	Burnelli .....	D12/76
D. 218,913	10/1970	Fredericks .....	D12/76

**OTHER PUBLICATIONS**

Interavia, Sept. 1974, p. 815, aircraft at upper left of page.

*Primary Examiner*—Alan P. Douglas  
*Attorney, Agent, or Firm*—Al Richardson

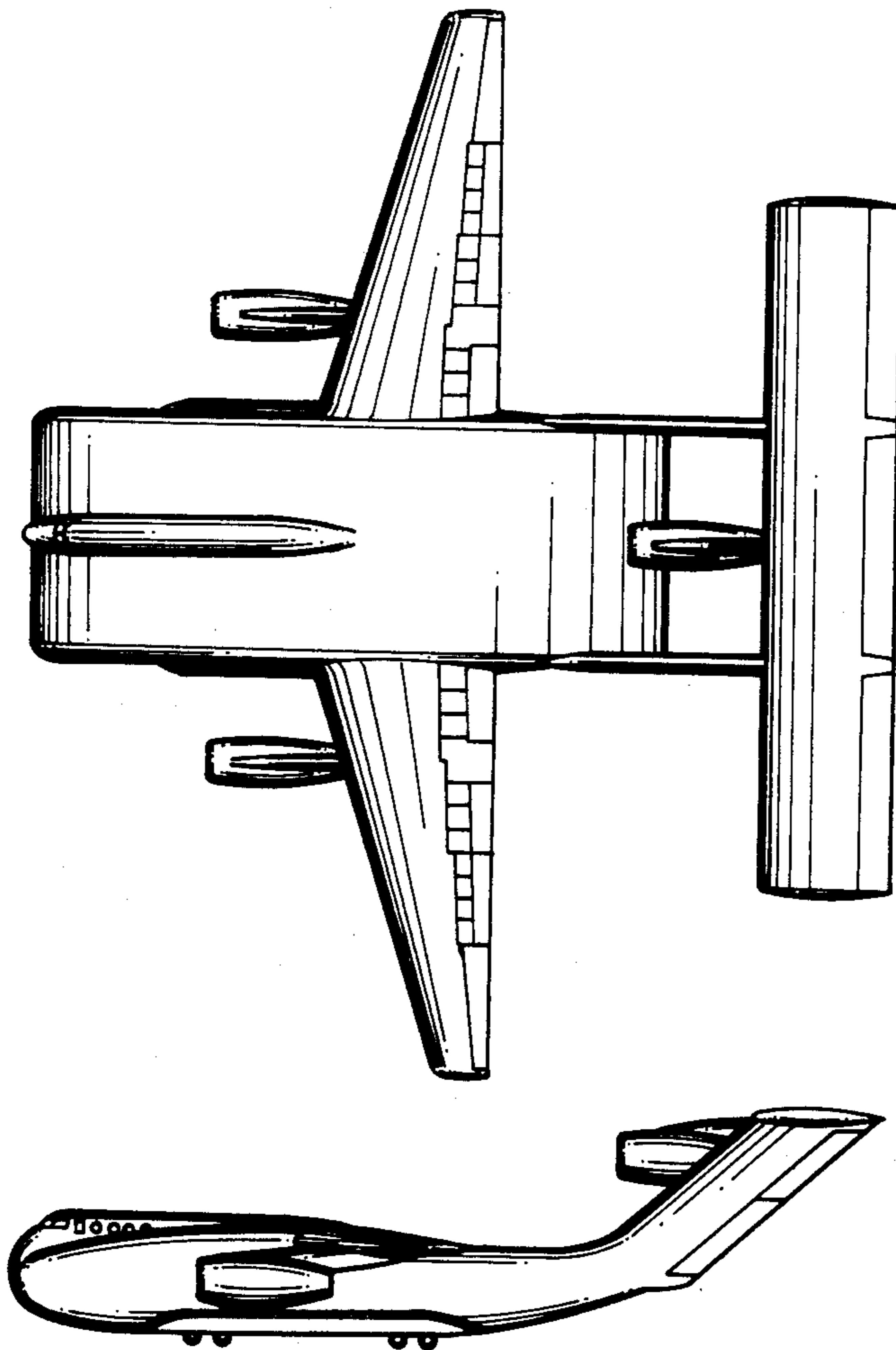
[57]

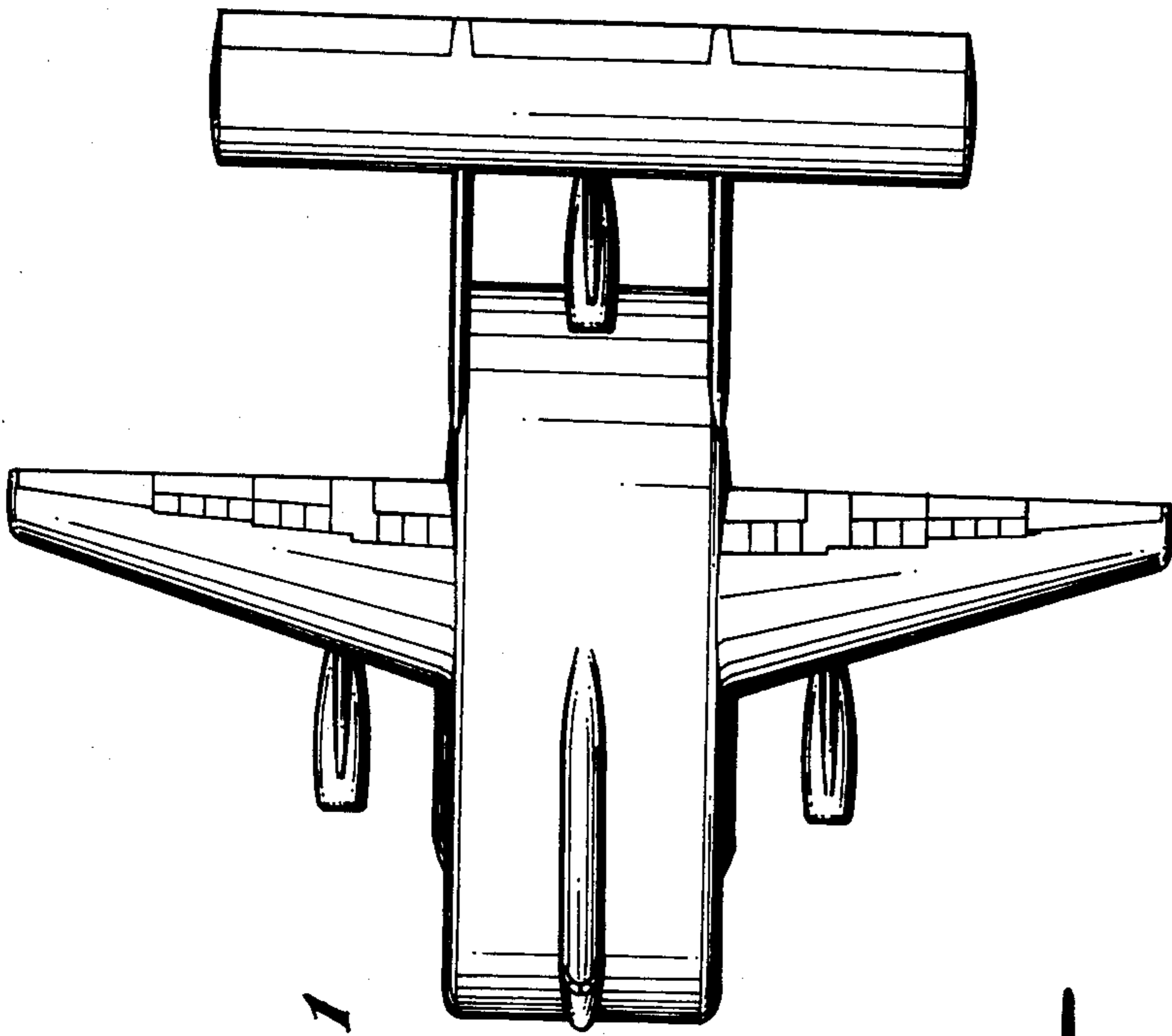
**CLAIM**

The ornamental design for an airplane, as shown and described.

**DESCRIPTION**

FIG. 1 is a top view of the new design for an airplane.  
FIG. 2 is a front view of the new design.  
FIG. 3 is a left side view of the new design.

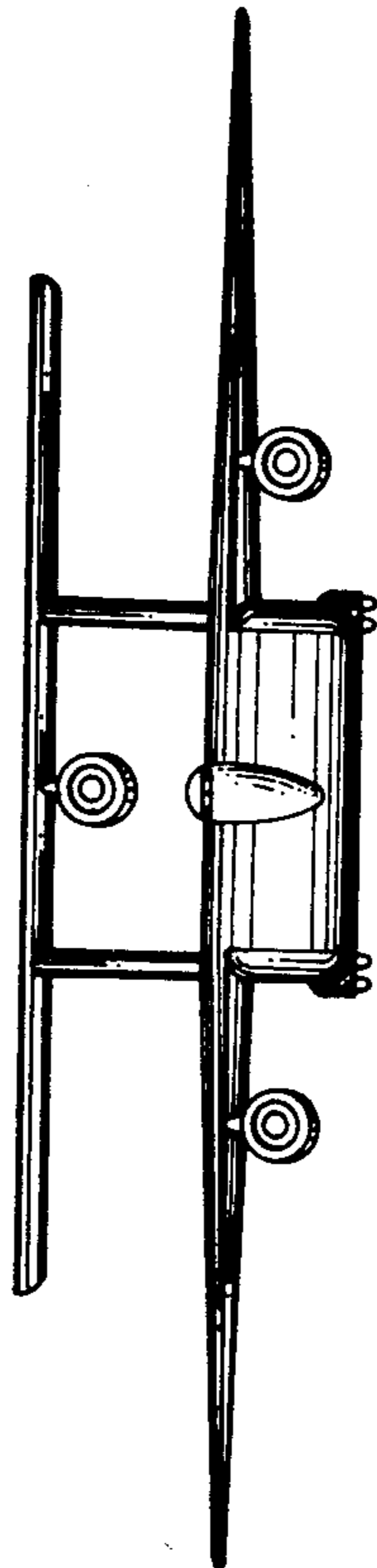




*Fig. 1*



*Fig. 3*



*Fig. 2*