

[54] **SHOULDER BAG STRAP HOLDER**

[76] Inventor: **James H. Fowble**, 2301 Broadway
No. 301, San Francisco, Calif. 94115

[**] Term: **14 Years**

[21] Appl. No.: **647,428**

[22] Filed: **Jan. 8, 1976**

[51] Int. Cl.² **D2-07**

[52] U.S. Cl. **D2/401**

[58] Field of Search **D2/401, 400, 381, 405,
D2/413, 425; 24/85 R, 86 R, 259 A**

2,086,767 7/1937 Haas D2/413 X
2,599,921 6/1952 Johnson D2/401 X
D. 30,754 5/1899 Priest D2/400
D. 35,751 2/1902 Campbell D2/401

Primary Examiner—Nelson C. Holtje
Attorney, Agent, or Firm—Ernest M. Anderson

[57] **CLAIM**

The ornamental design for a shoulder bag strap holder, as shown and described.

DESCRIPTION

FIG. 1 is a front perspective view of a shoulder bag strap holder showing my new design;
FIG. 2 is a top plan view thereof;
FIG. 3 is a front elevational view thereof;
FIG. 4 is a left side elevational view thereof;
FIG. 5 is a rear elevational view thereof;
FIG. 6 is an inverted right side elevational view thereof.

[56] **References Cited**

U.S. PATENT DOCUMENTS

1,488,594 4/1924 Gaschke D2/413 X
1,949,331 2/1934 Richardson 24/259 A

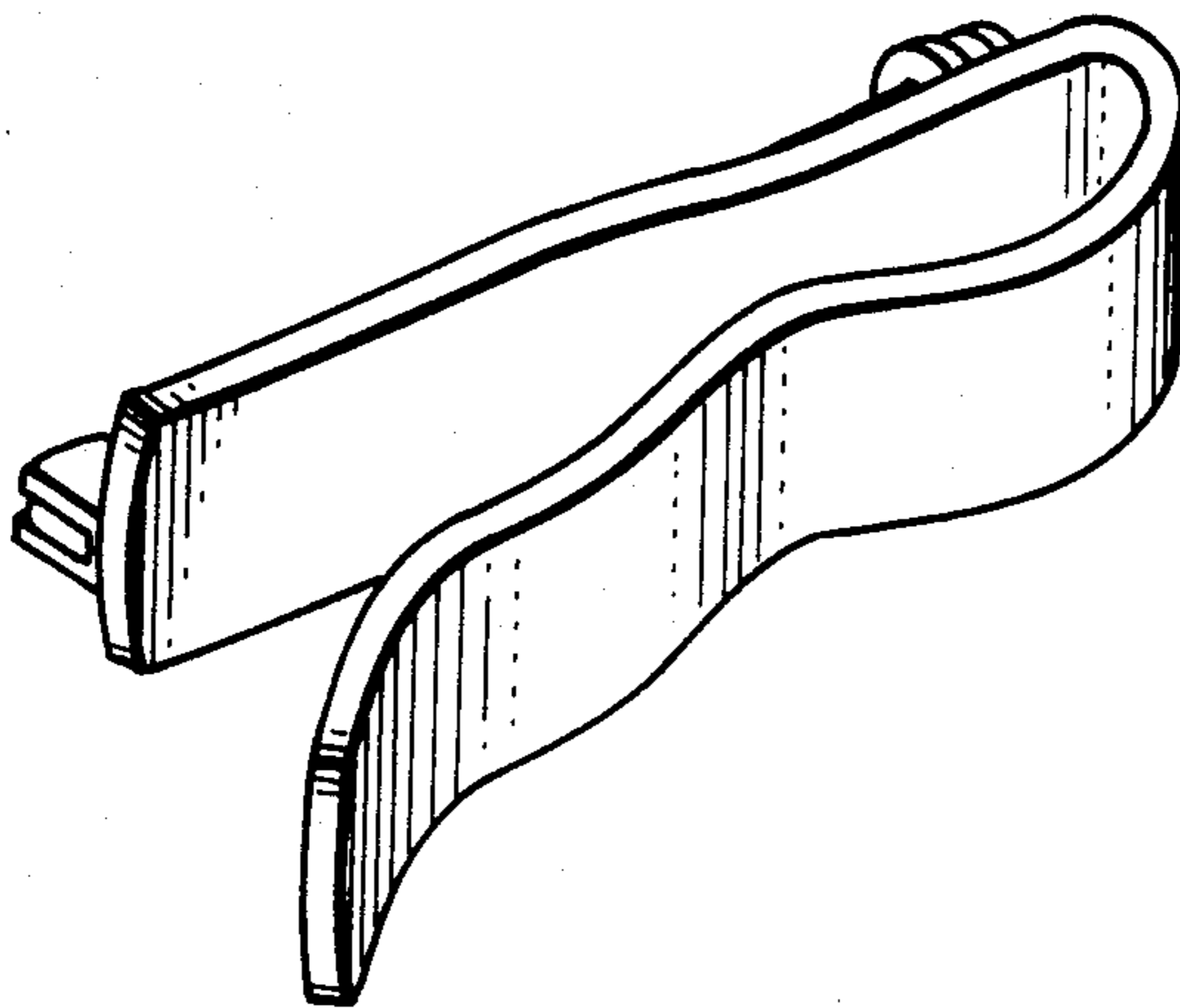

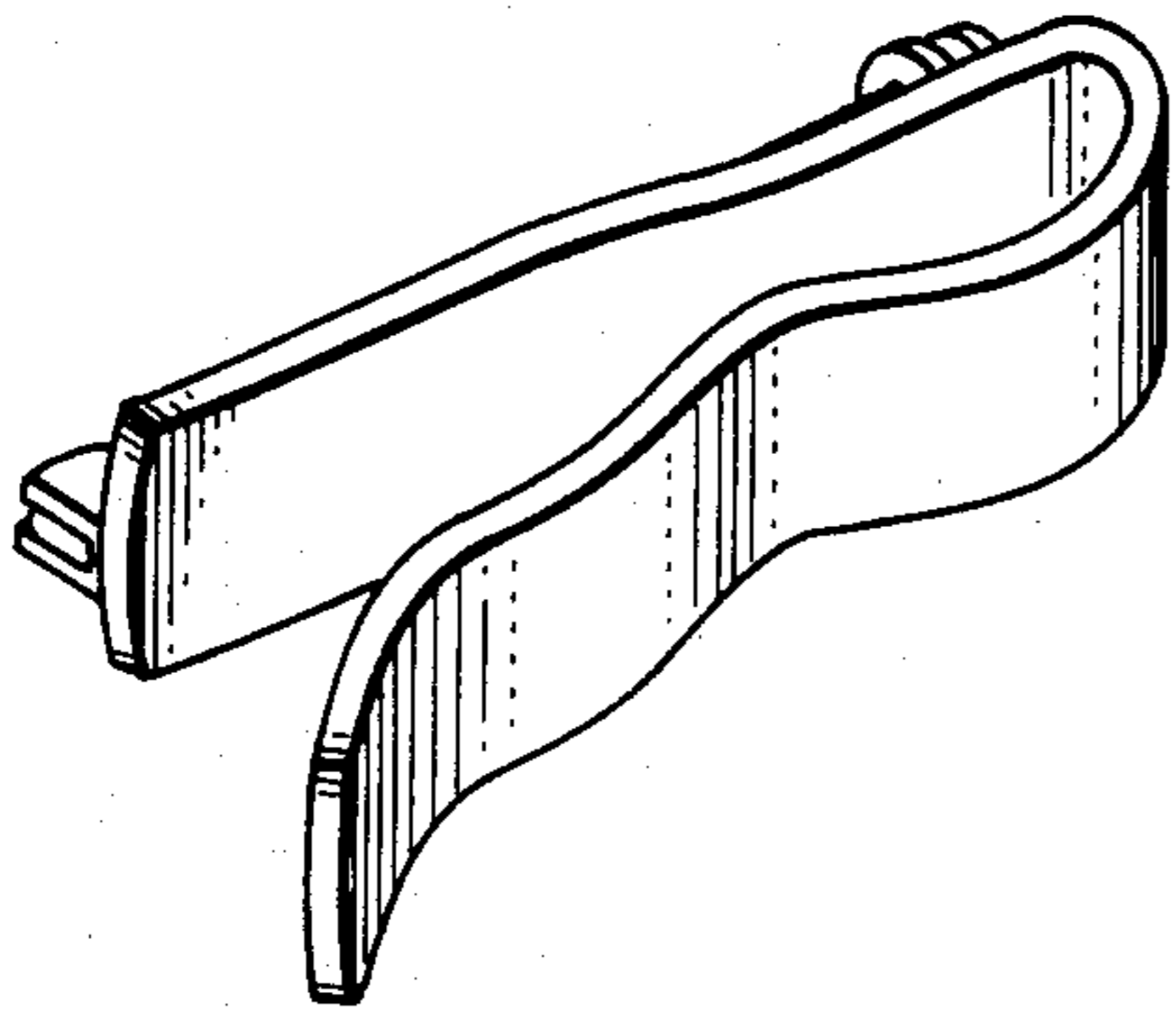

FIG. 1.

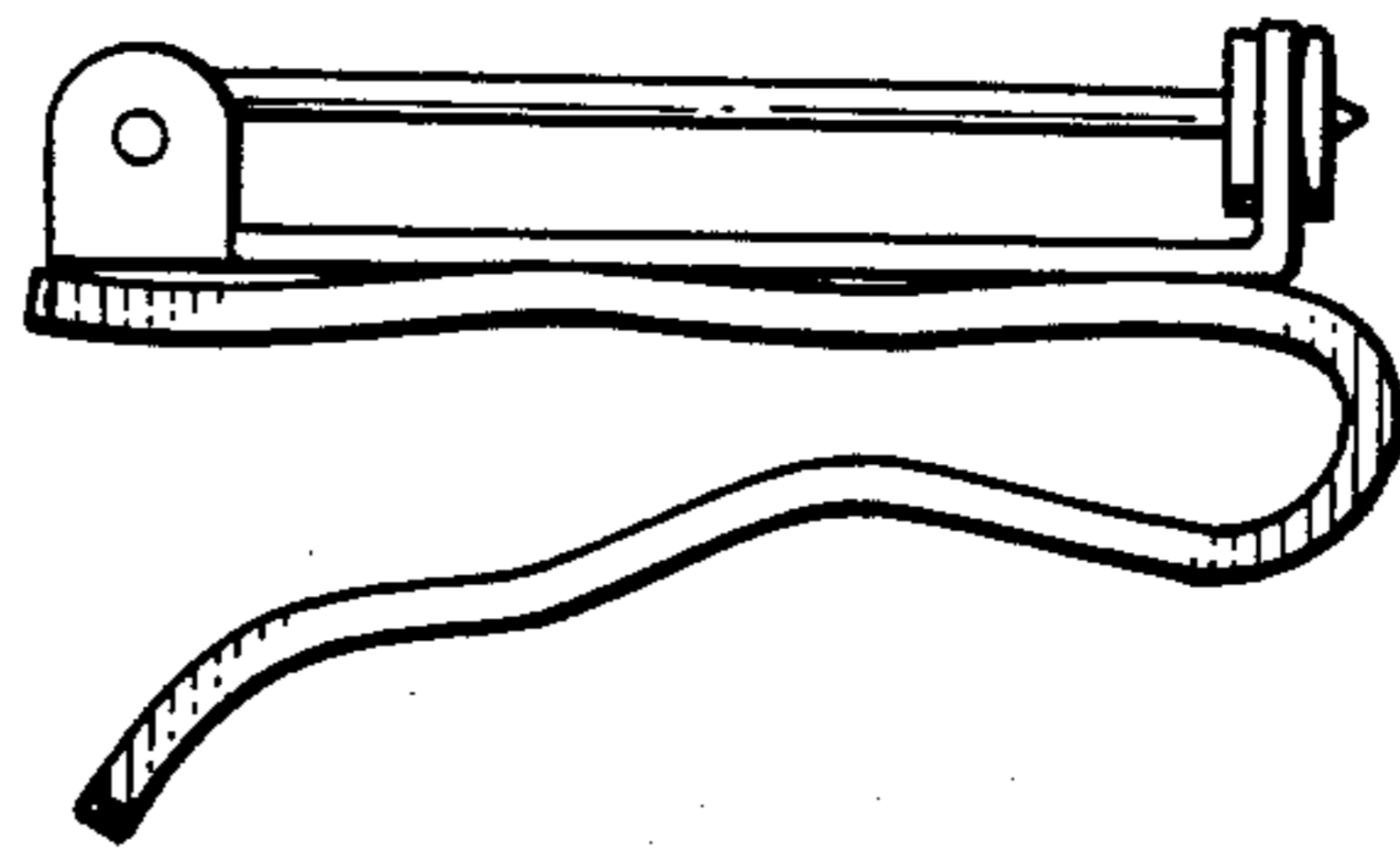

FIG. 2.

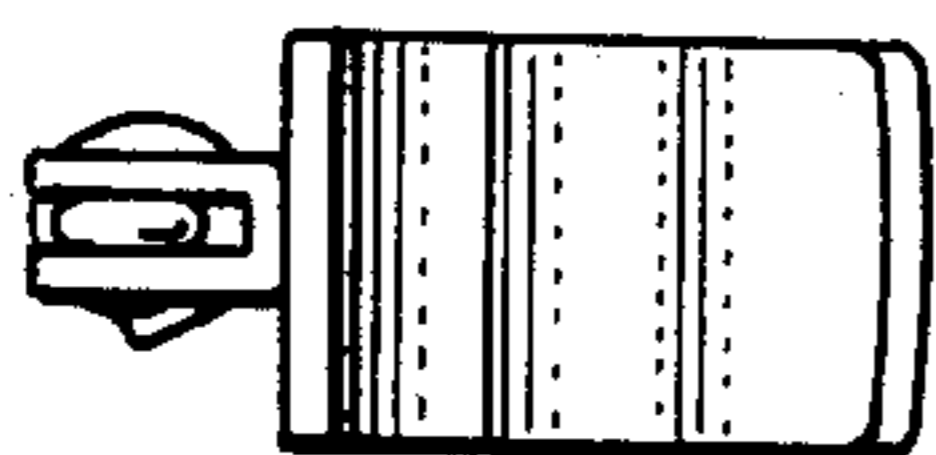

FIG. 4.

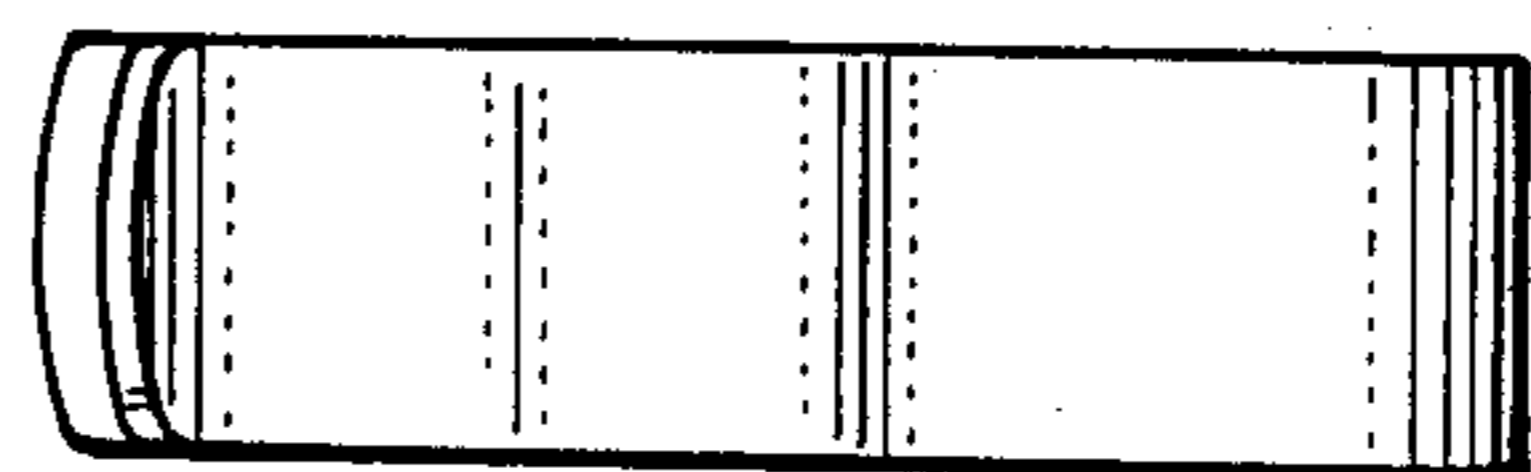

FIG. 3.

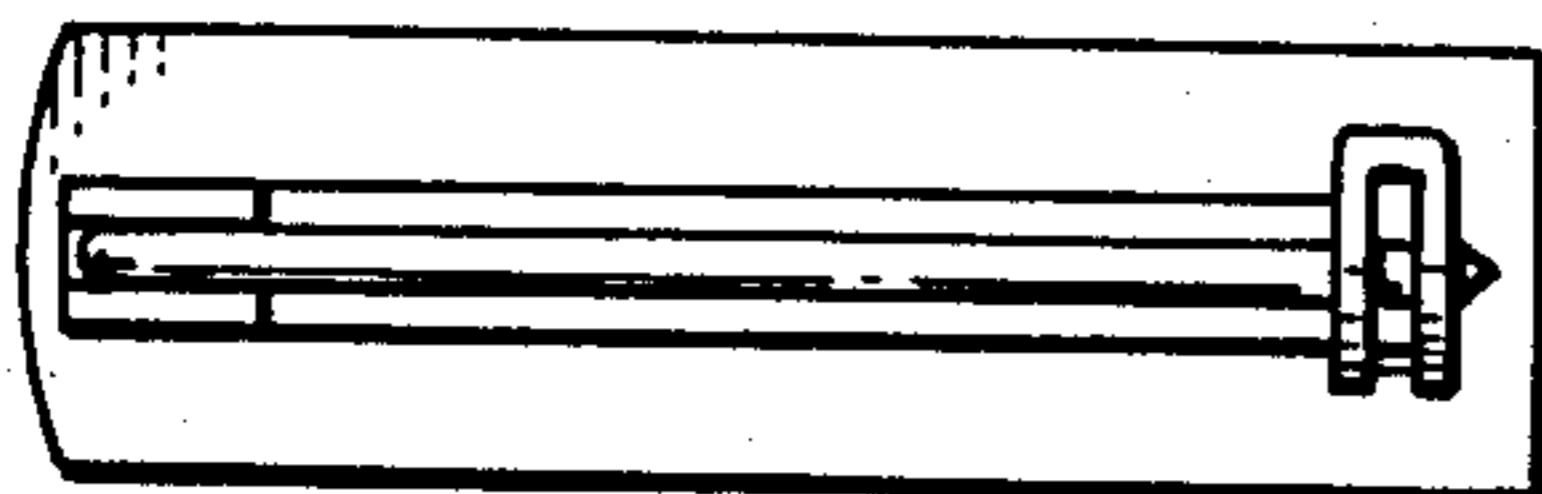

FIG. 5.

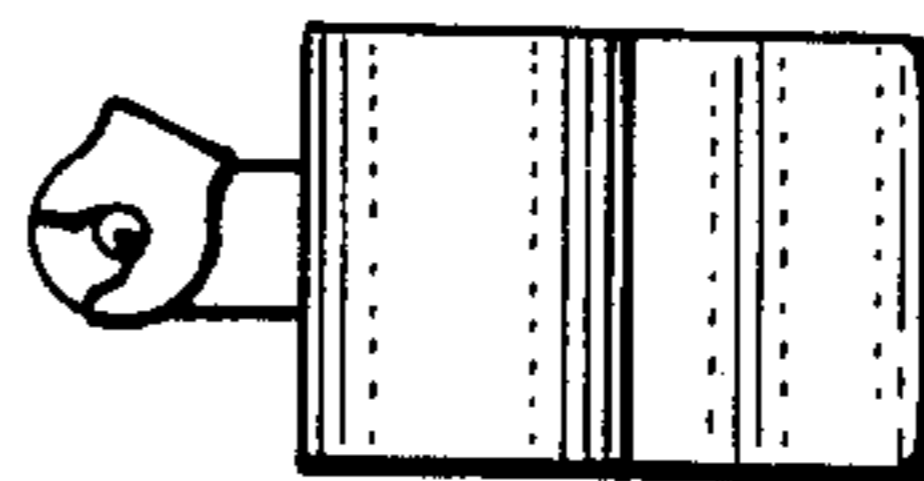

FIG. 6.