

[54] COMBINED GUIRO AND SHAKER

[76] Inventor: **Martin B. Cohen**, 68 Saddlewood Drive, Hillsdale, N.J. 07642

[**] Term: **14 Years**

[21] Appl. No.: **627,404**

[22] Filed: **Oct. 30, 1975**

Related U.S. Application Data

[63] Continuation-in-part of Ser. No. 482,047, June 24, 1974, abandoned.

[51] Int. Cl. **D17-04**

[52] U.S. Cl. **D56/1 E**

[58] Field of Search **D56/1 R, 1 B, 1 E; 84/1, 411 R, 410, 453, 329, 402; 150/52 A, 52 H; 224/45 R, 45 L**

[56] **References Cited**

OTHER PUBLICATIONS

The Music Trades, Dec. 1973, p. 68 - Latin Percussion "Torpedo," top right.

Rogers Drums Catalog 64R, rec'd. Dec. 22, 1964, p. 82 - Guiro No. 117 at top.

American Machinist, Sept. 16, 1944, p. 117 - Bomb & Holder, midpage.

Primary Examiner—Robert C. Spangler

Assistant Examiner—Louis S. Zarfes

Attorney, Agent, or Firm—Allison C. Collard

[57] **CLAIM**

The ornamental design for a combined guiro and shaker, substantially as shown and described.

DESCRIPTION

FIG. 1 is a perspective view of a combined guiro and shaker showing my new design, the opposite being identical and the continuous knurling being shown partially for ease of illustration; and FIG. 2 is an end view thereof.

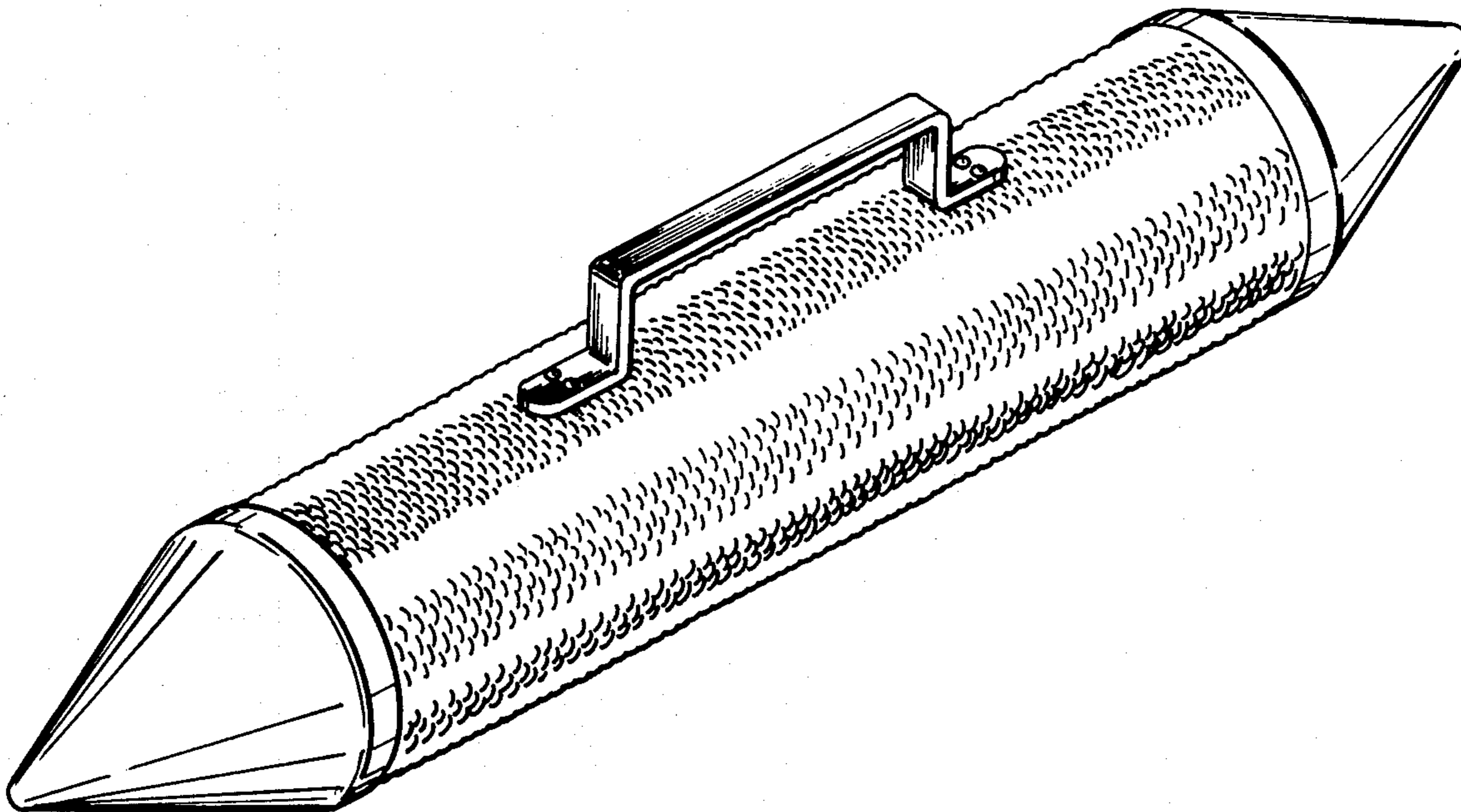

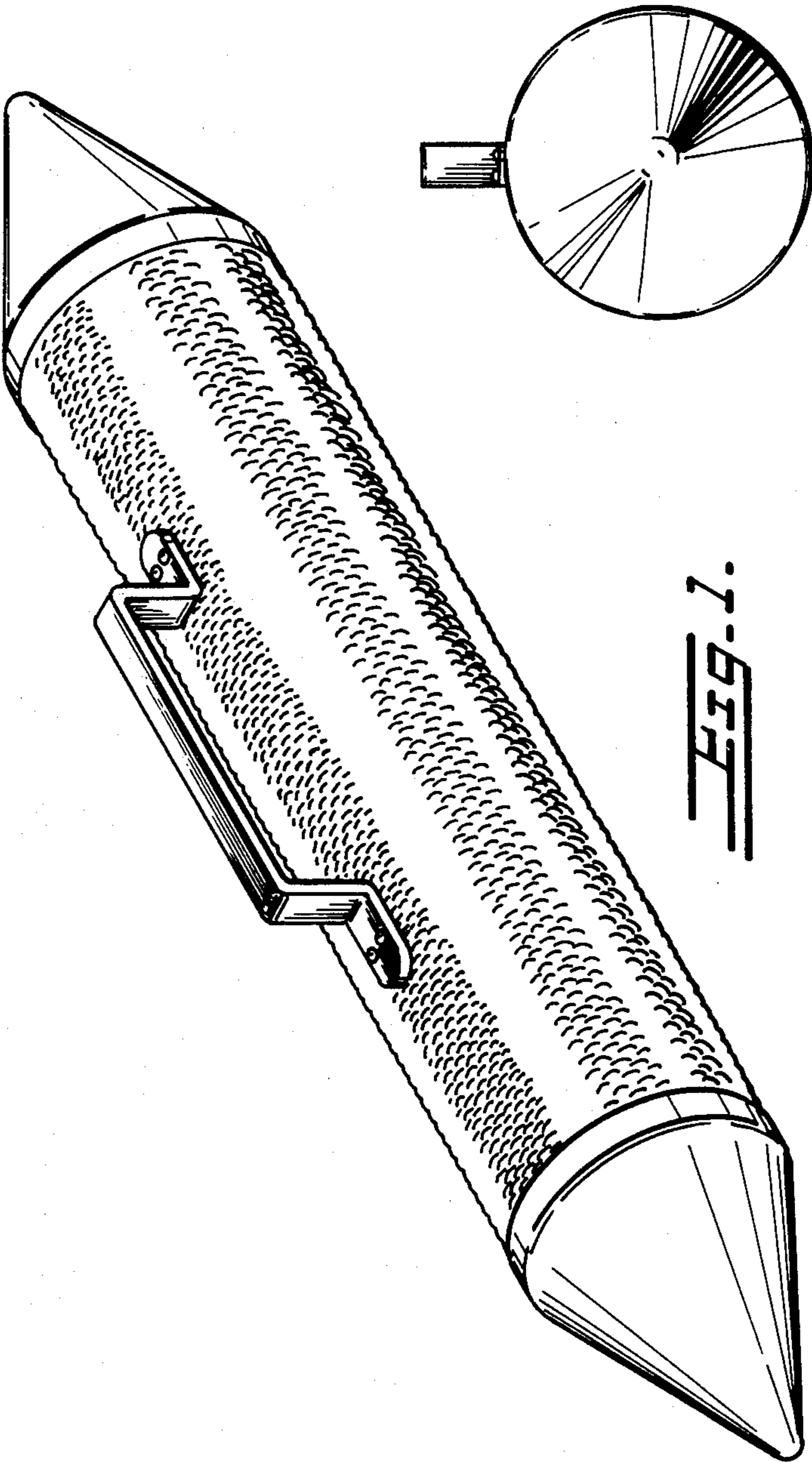

FIG. 1

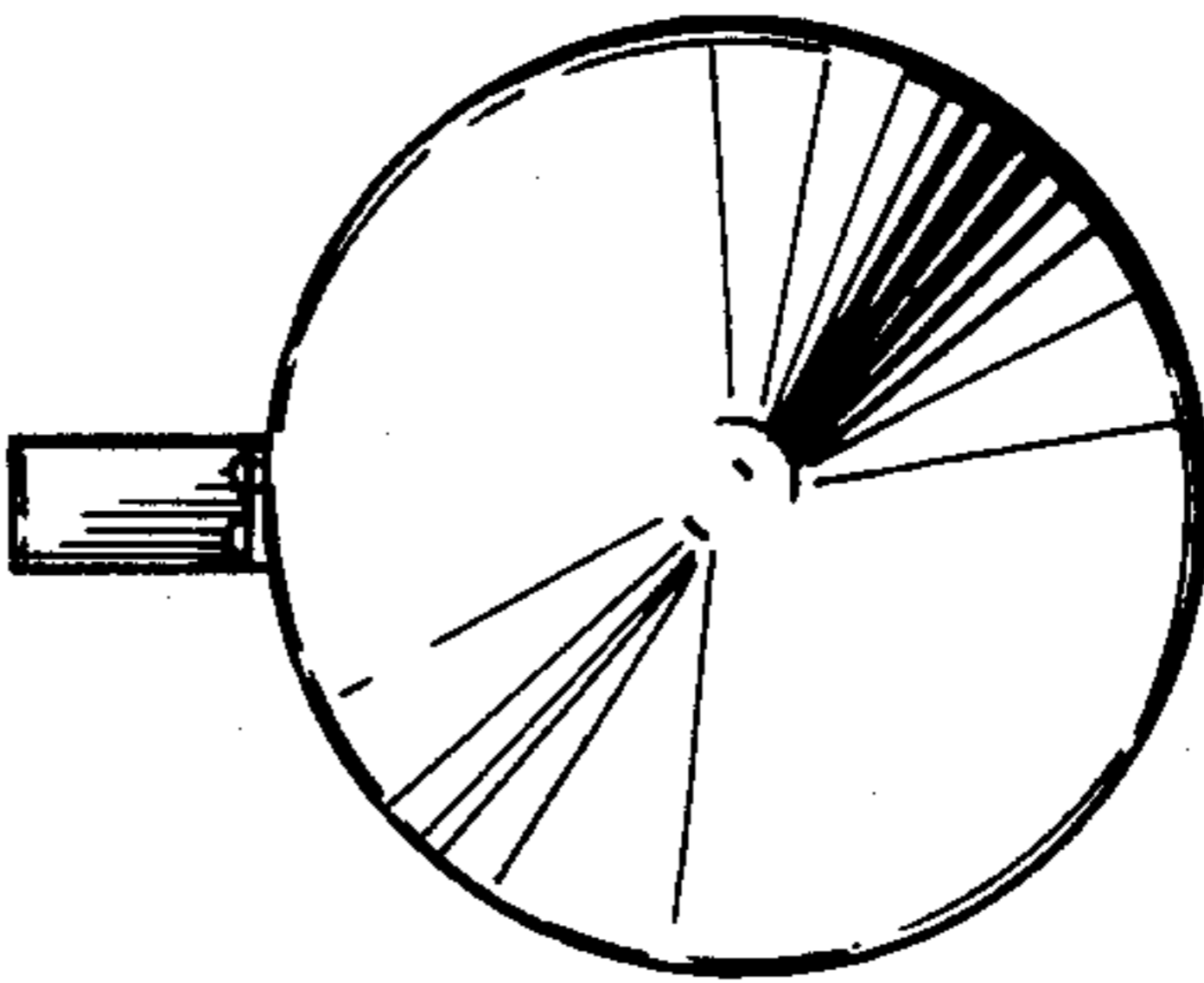

FIG. 2