

[54] **FROSTPROOF HYDRANT**
 [76] Inventor: **H. Ronald Ratnik**, 222 Weymouth Drive, Rochester, N.Y. 14625
 [**] Term: **14 Years**
 [21] Appl. No.: **629,044**
 [22] Filed: **Nov. 5, 1975**
 [51] Int. Cl. **D23-01**
 [52] U.S. Cl. **D23/12**
 [58] Field of Search **D23/12; 137/301-307**

2,688,976 9/1954 Baker 137/301 X
 3,858,599 1/1975 Carlson 137/307 X

Primary Examiner—James R. Largen
Attorney, Agent, or Firm—W. W. Kurz

[57] **CLAIM**

The ornamental design for a frostproof hydrant, as shown and described.

DESCRIPTION

FIG. 1 is a top plan view of a frostproof hydrant showing my new design;
 FIG. 2 is a right side elevational view thereof, the opposite side being a mirror image of the side shown;
 FIG. 3 is a front elevational view thereof;
 FIG. 4 is a rear elevational view thereof; and
 FIG. 5 is a bottom plan view thereof.

[56] **References Cited**
U.S. PATENT DOCUMENTS
 1,846,623 2/1932 Volk et al. 137/305
 2,109,187 2/1938 Vogel 137/307 X

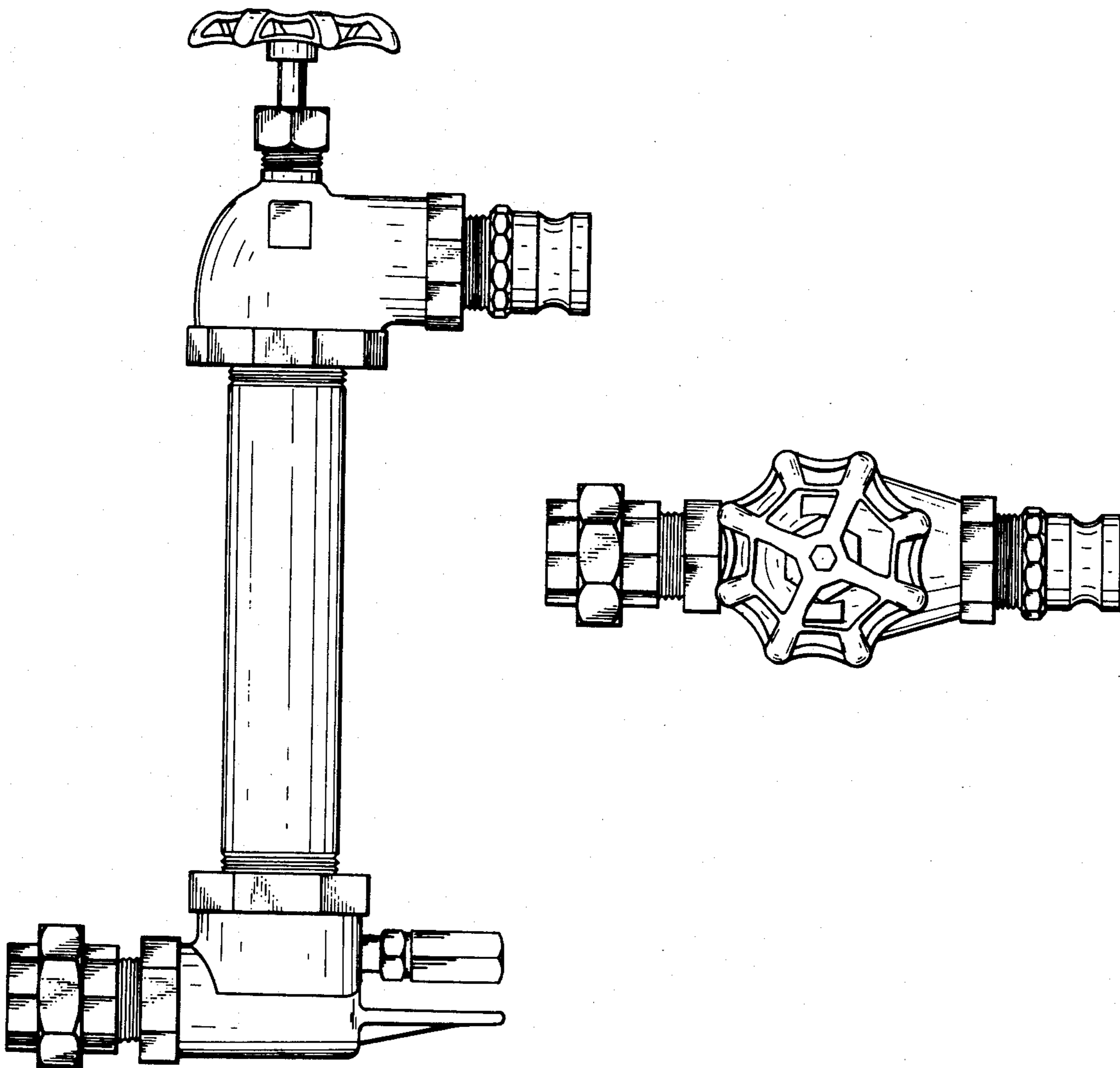

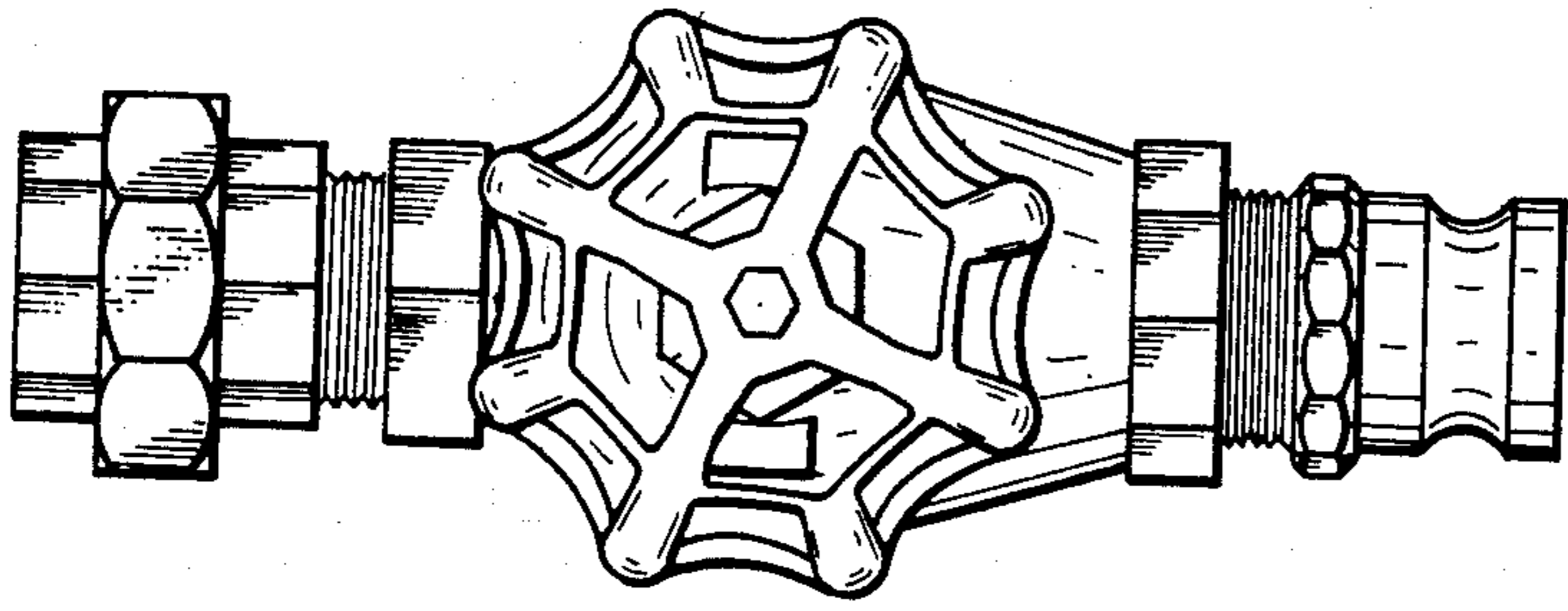

FIG. 1

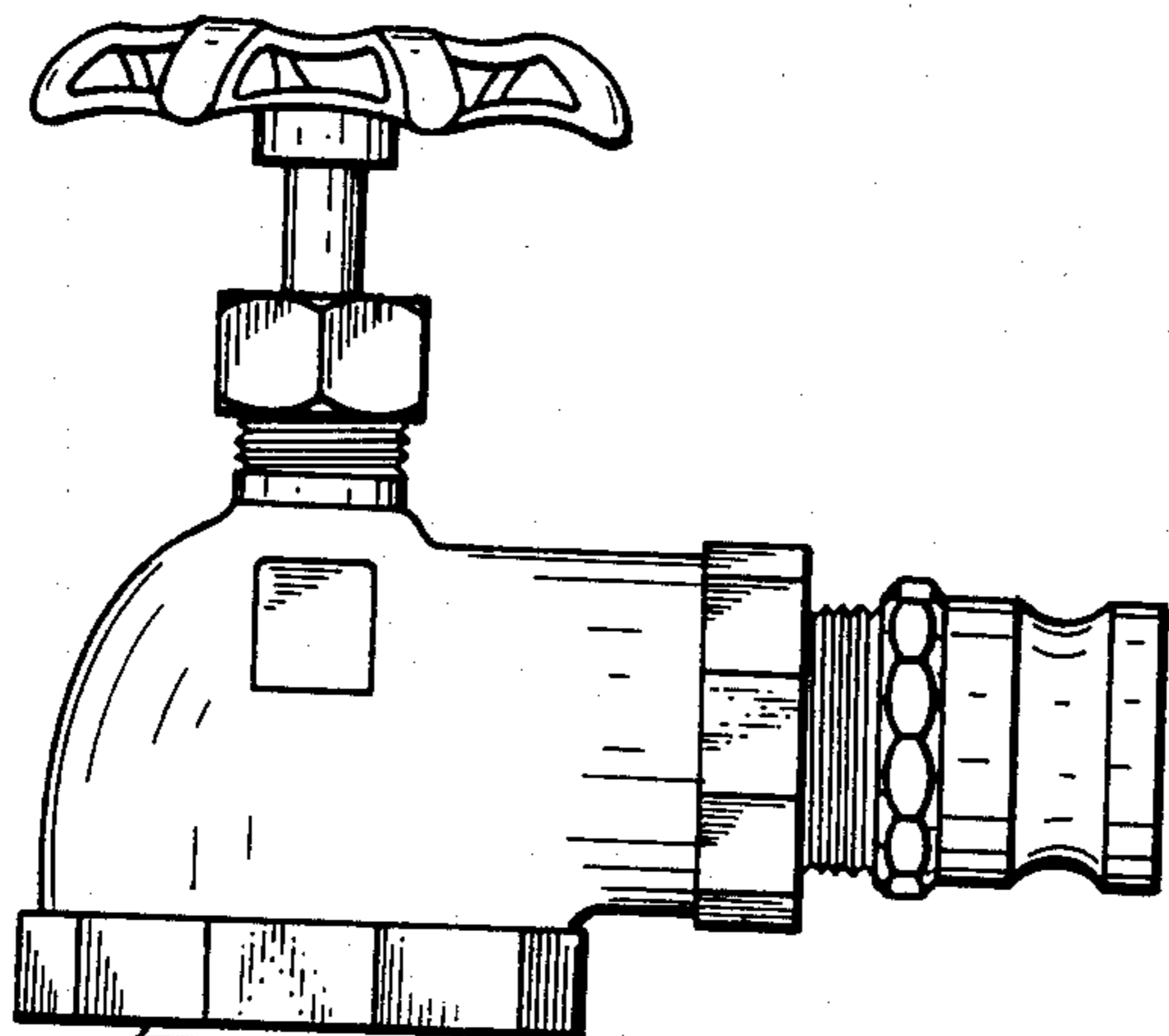

FIG. 2

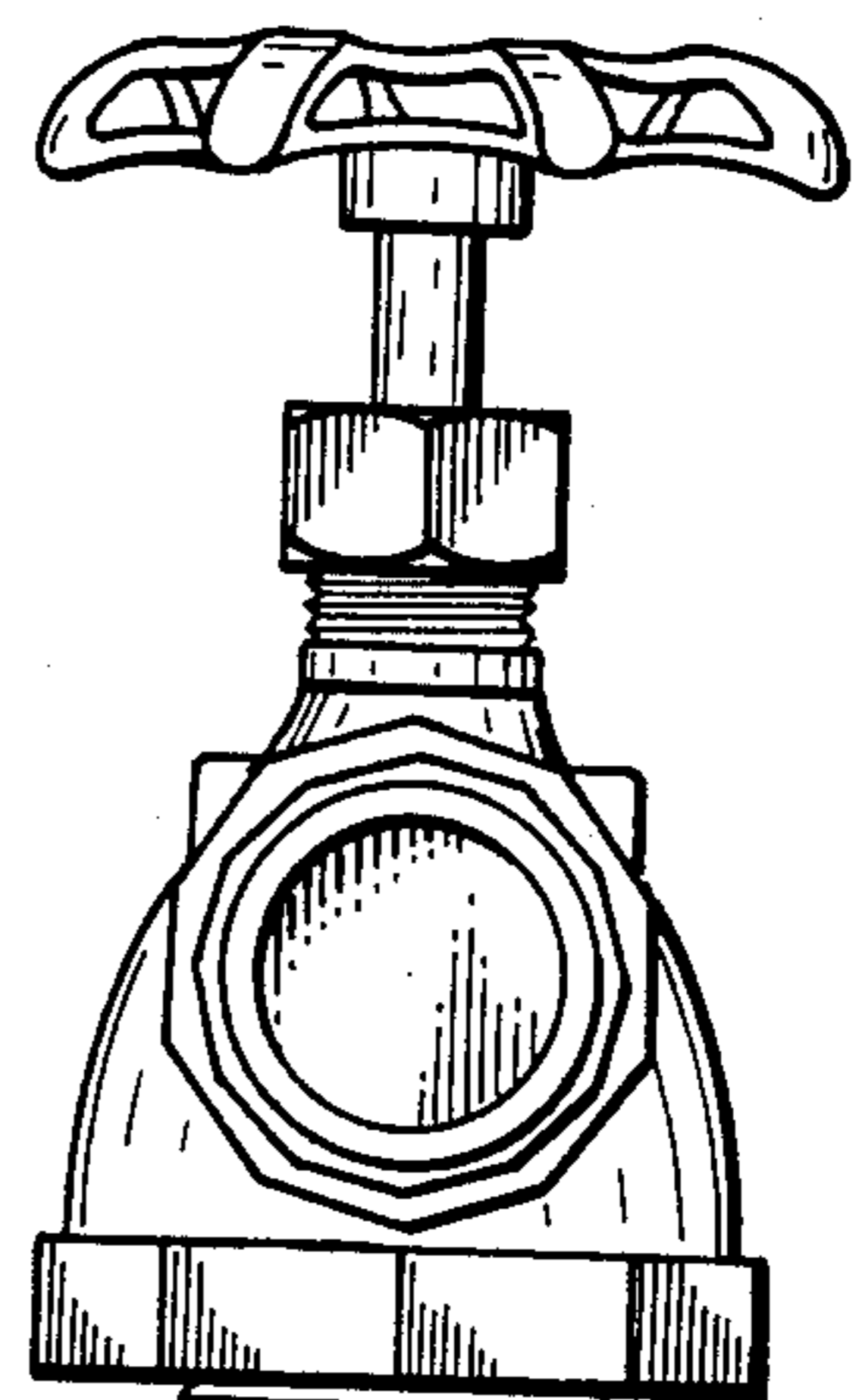
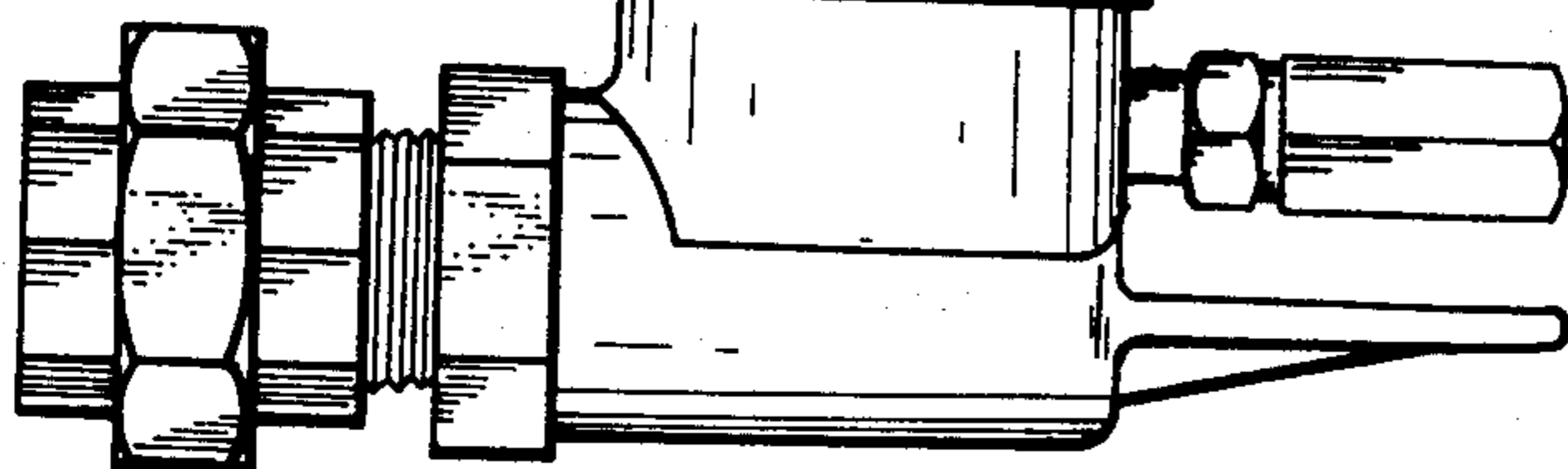
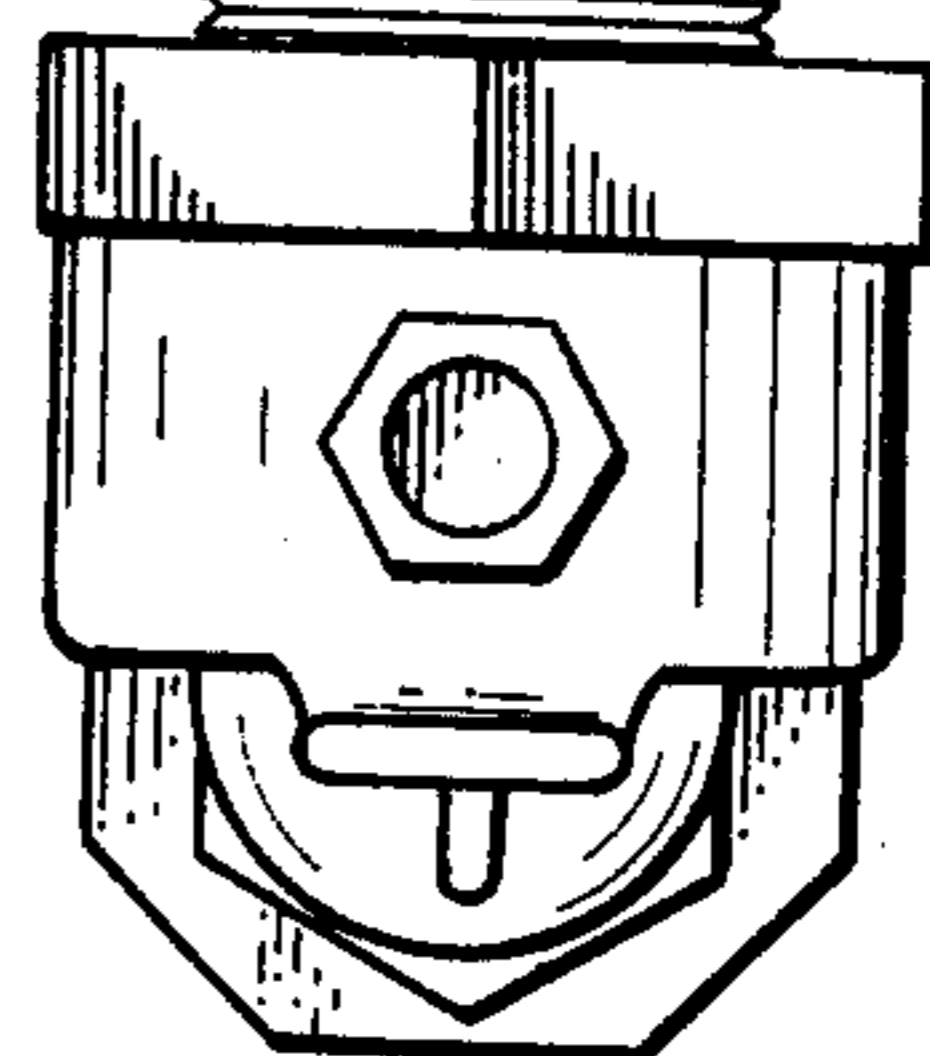

FIG. 3



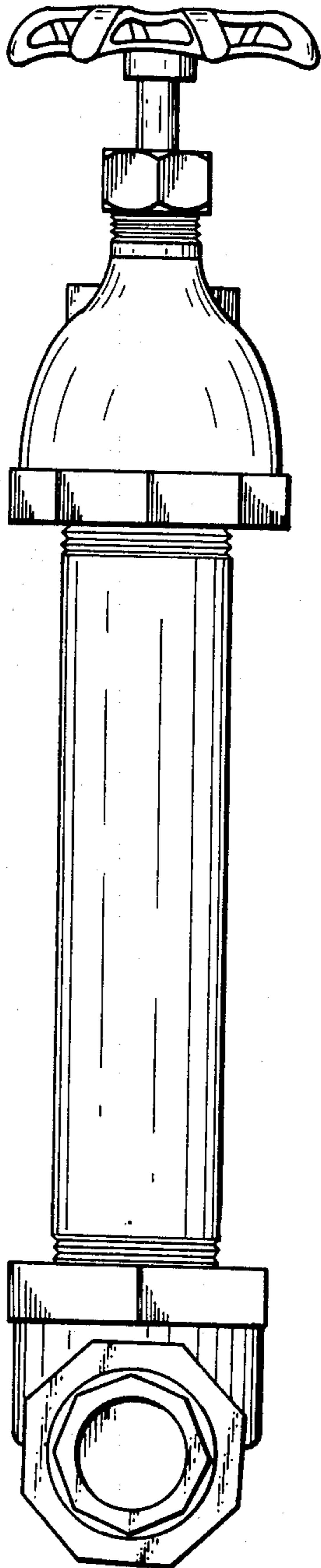

FIG. 4

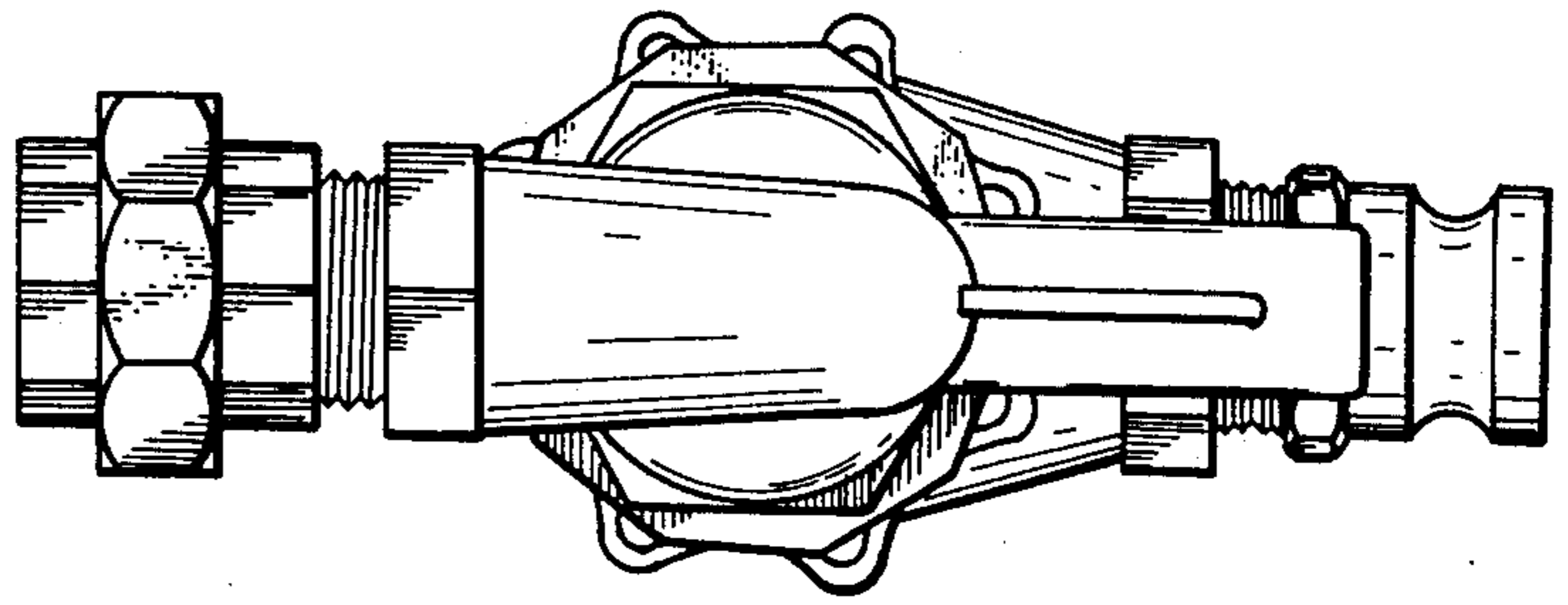

FIG. 5