

[54] MOTORCYCLE SAFETY BAR

[75] Inventors: Harold H. Larsen, Long Beach; Robert E. Oehring, Norwalk, both of Calif.

[73] Assignee: Bates Industries, Inc., Long Beach, Calif.

[**] Term: 14 Years

[21] Appl. No.: 400,396

[22] Filed: Sept. 24, 1973

[51] Int. Cl. D12-11

[52] U.S. Cl. D12/114

[58] Field of Search D12/114, 126; 280/289

[56] References Cited

FOREIGN PATENT DOCUMENTS

685,317 12/1952 United Kingdom 280/289

OTHER PUBLICATIONS

Dealer's Voice, Feb.-Mar. 1969, p. 32, Safety Bar, bottom left side of page.

J. C. Whitney Catalog No. 292, c. 1971, p. 121, Safety Bar, 1, second box up from bottom left side of page. Shillingford & Sons Parts & Accessories Catalog, Rec'd. 7/7/69, p. 33, Safety Bar, top right side of page. Cycle World, 7/73, p. 120, Safety Bar, bottom left side of page.

Cycle World, 8/73, p. 120, Safety Bar, top left side of page.

Cycle World, 7/73, p. 26, Safety Bar, bottom center of page.

Primary Examiner—Wallace R. Burke

Assistant Examiner—James M. Gandy

Attorney, Agent, or Firm—Francis A. Utecht

[57] CLAIM

The ornamental design for a motorcycle safety bar, substantially as shown.

DESCRIPTION

FIG. 1 is a perspective view of a motorcycle safety bar showing our new design the broken lines being for illustrative purposes only;

FIG. 2 is a right side elevational view thereof;

FIG. 3 is a rear elevational view thereof;

FIG. 4 is a top plan view thereof; and

FIG. 5 is a bottom plan view.

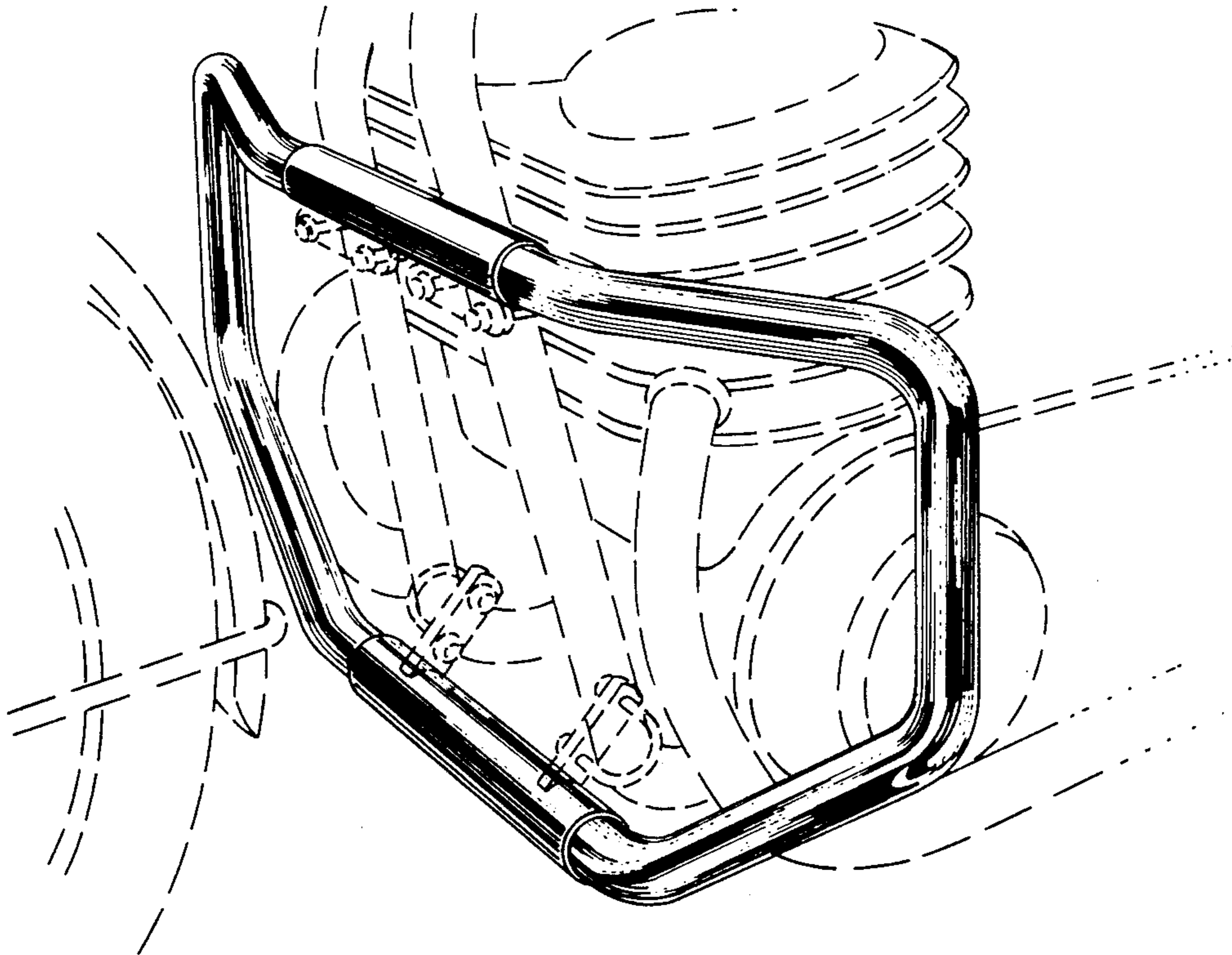

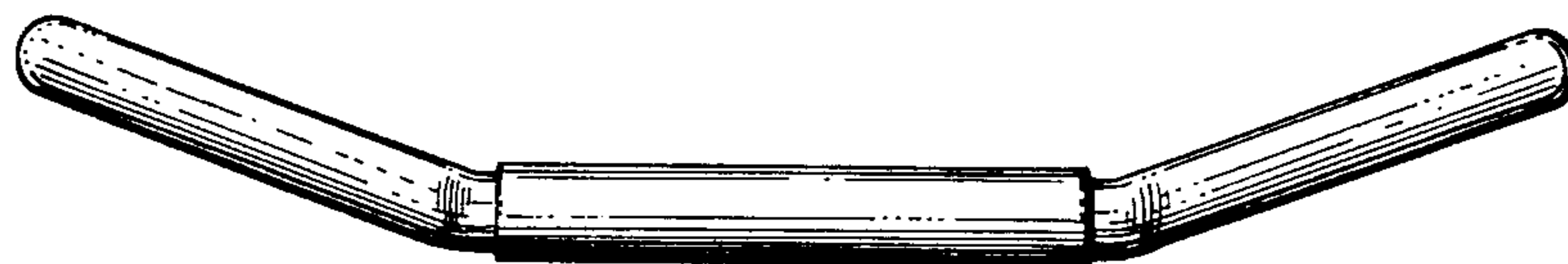
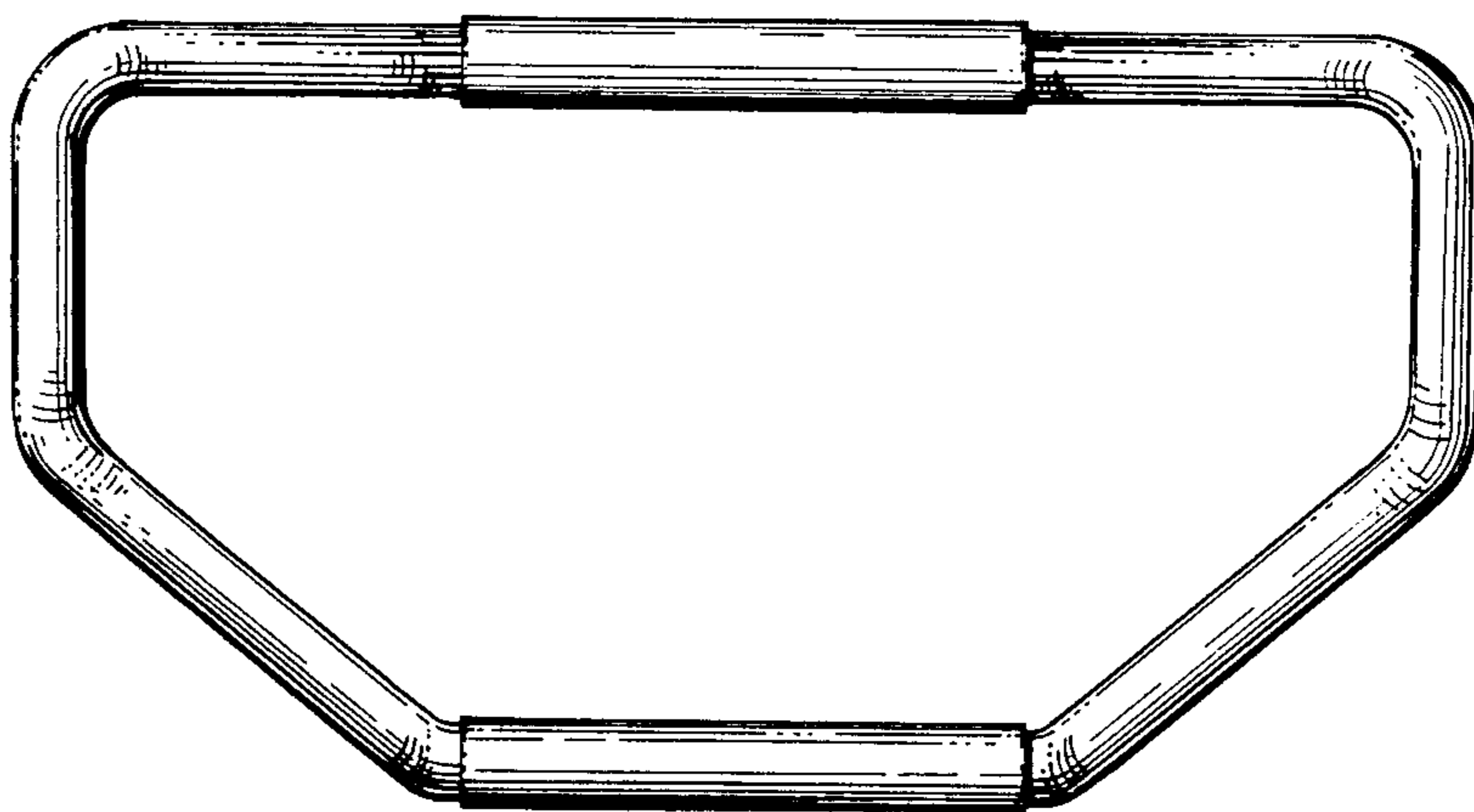
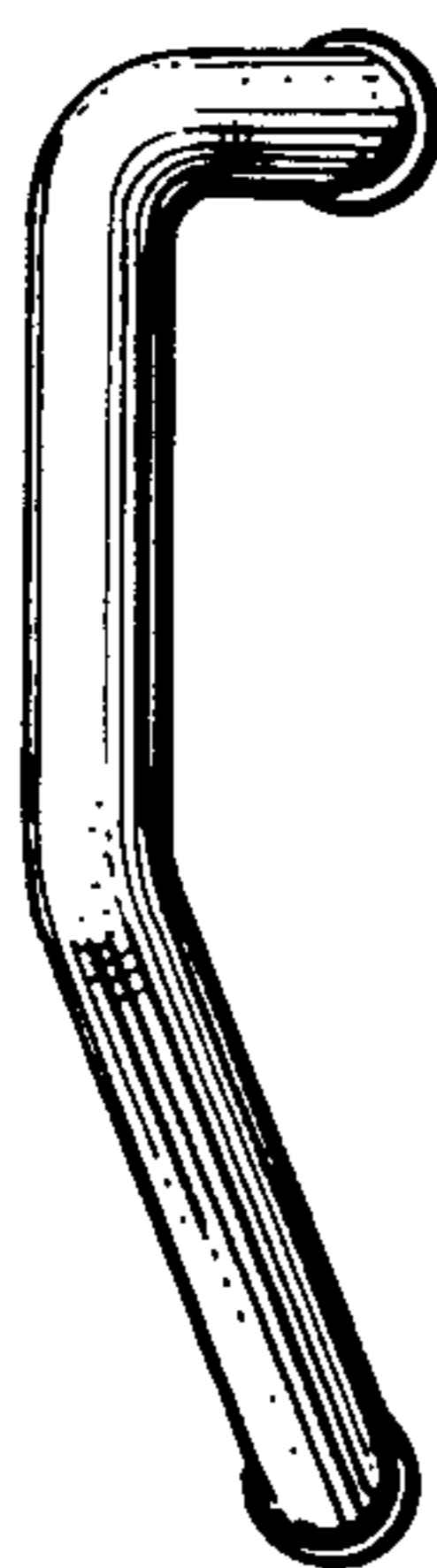
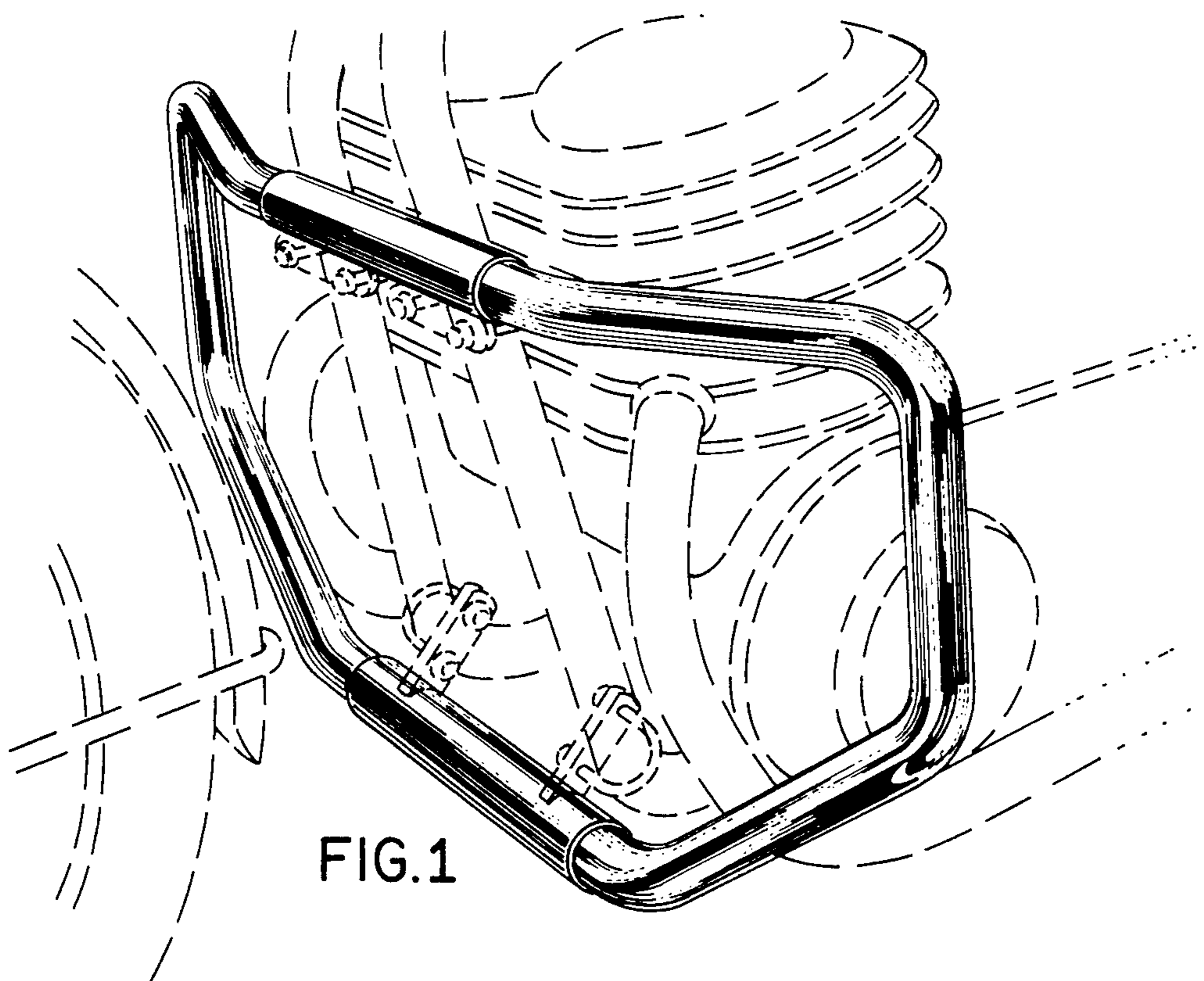

UNITED STATES PATENT OFFICE
CERTIFICATE OF CORRECTION

Patent No. D-244,519

Dated May 31, 1977

Inventor(s) Harold H. Larsen

It is certified that error appears in the above-identified patent and that said Letters Patent are hereby corrected as shown below:

Please change the title of the invention, wherever occurring, to read -- MOTORCYCLE ENGINE GUARD --.

Signed and Sealed this

thirtieth **Day of** *August 1977*

[SEAL]

Attest:

RUTH C. MASON
Attesting Officer

C. MARSHALL DANN
Commissioner of Patents and Trademarks