

[54] TOOL HOLDER WITH DOUBLE FLANGE

[75] Inventor: Warren E. Ponemon, Mill Neck, N.Y.

[73] Assignee: Autonumerics, Inc., Hauppauge, N.Y.

[**] Term: 14 Years

[21] Appl. No.: 616,190

[22] Filed: Sept. 24, 1975

[51] Int. Cl. D15-99

[52] U.S. Cl. D15/140

[58] Field of Search D54/13 A, 13 R; 279/103, 1 A; D15/140

[56] References Cited

U.S. PATENT DOCUMENTS

2,579,082	12/1951	Kramer	279/103
2,719,722	10/1955	Nickless	279/103 X
3,719,376	3/1973	Baturka	279/1 A

3,759,536	9/1973	Bronzini	279/103 X
D. 207,346	4/1967	Lutz	D54/13 A

Primary Examiner—Alan P. Douglas
Attorney, Agent, or Firm—Davidson C. Miller

[57] CLAIM

The ornamental design for a tool holder with double flange, as shown and described.

DESCRIPTION

FIG. 1 is a perspective view of a first embodiment of the tool holder with double flange, FIG. 2 is a side view of said first embodiment, FIG. 3 is a top view of said first embodiment, FIG. 4 is a bottom view of said first embodiment, FIG. 5 is a perspective view of a second embodiment of the tool holder with double flange, FIG. 6 is a side view of said second embodiment, FIG. 7 is a top view of said second embodiment, and FIG. 8 is a bottom view of said second embodiment.

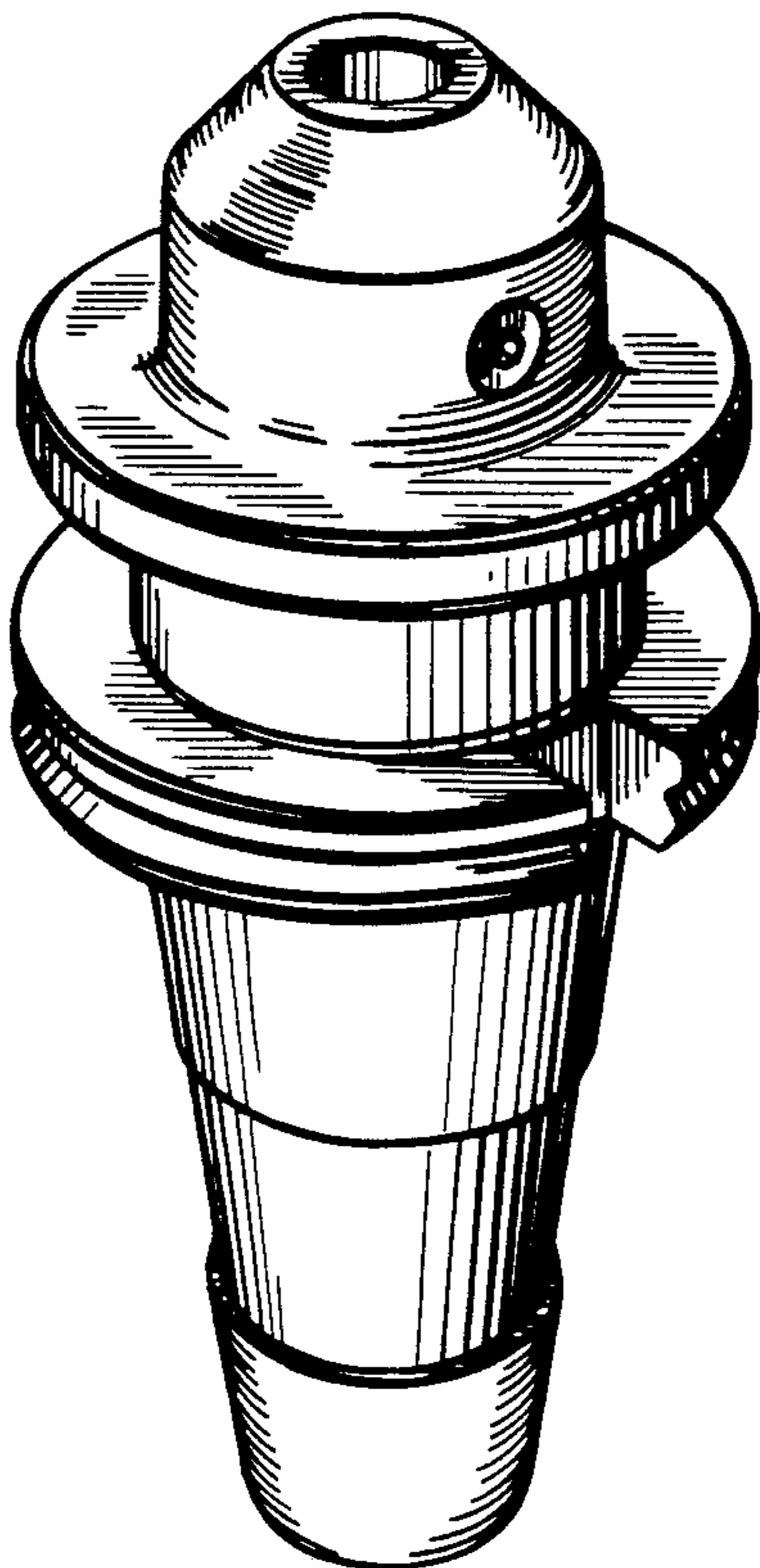

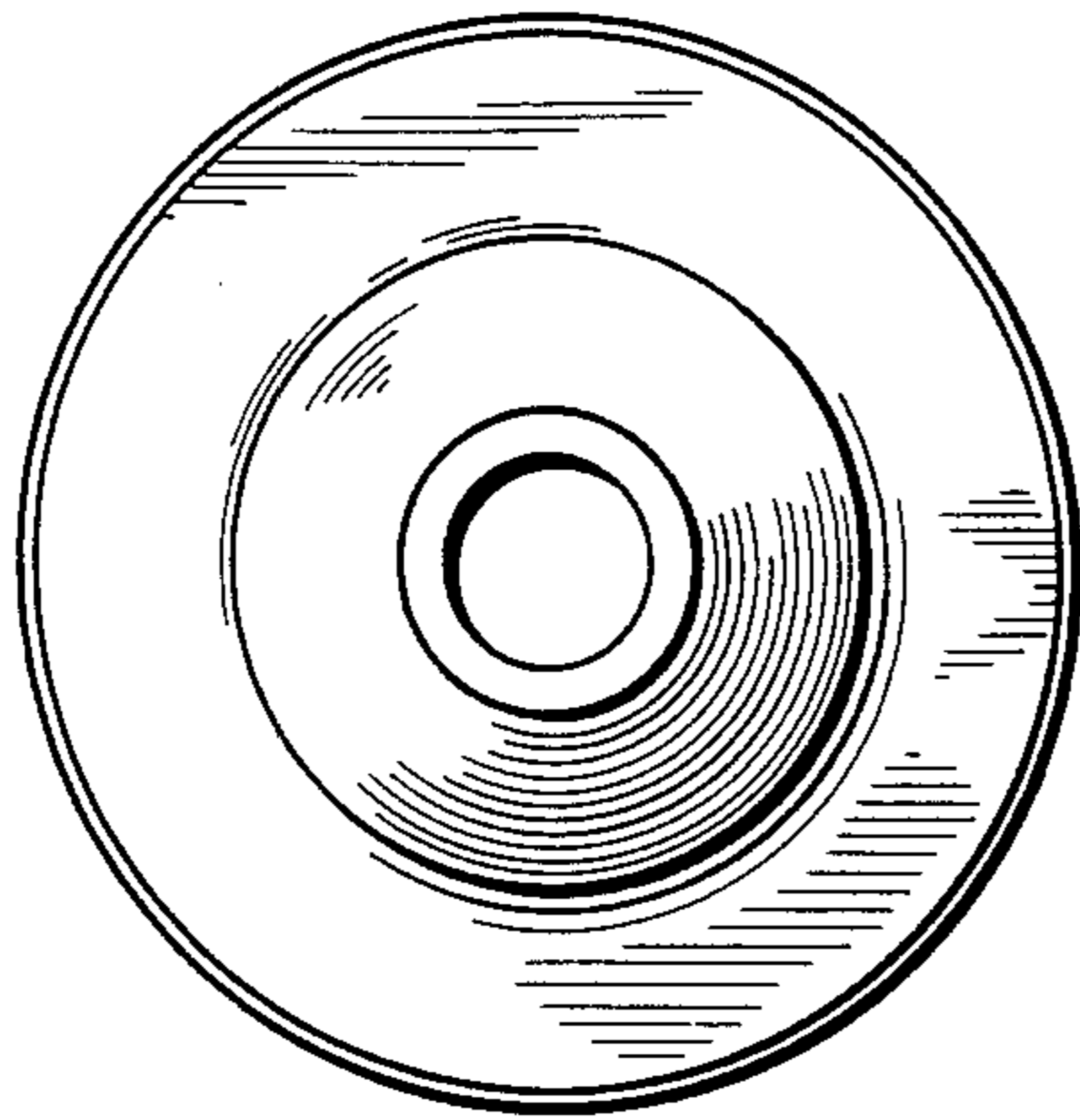

FIG. 3

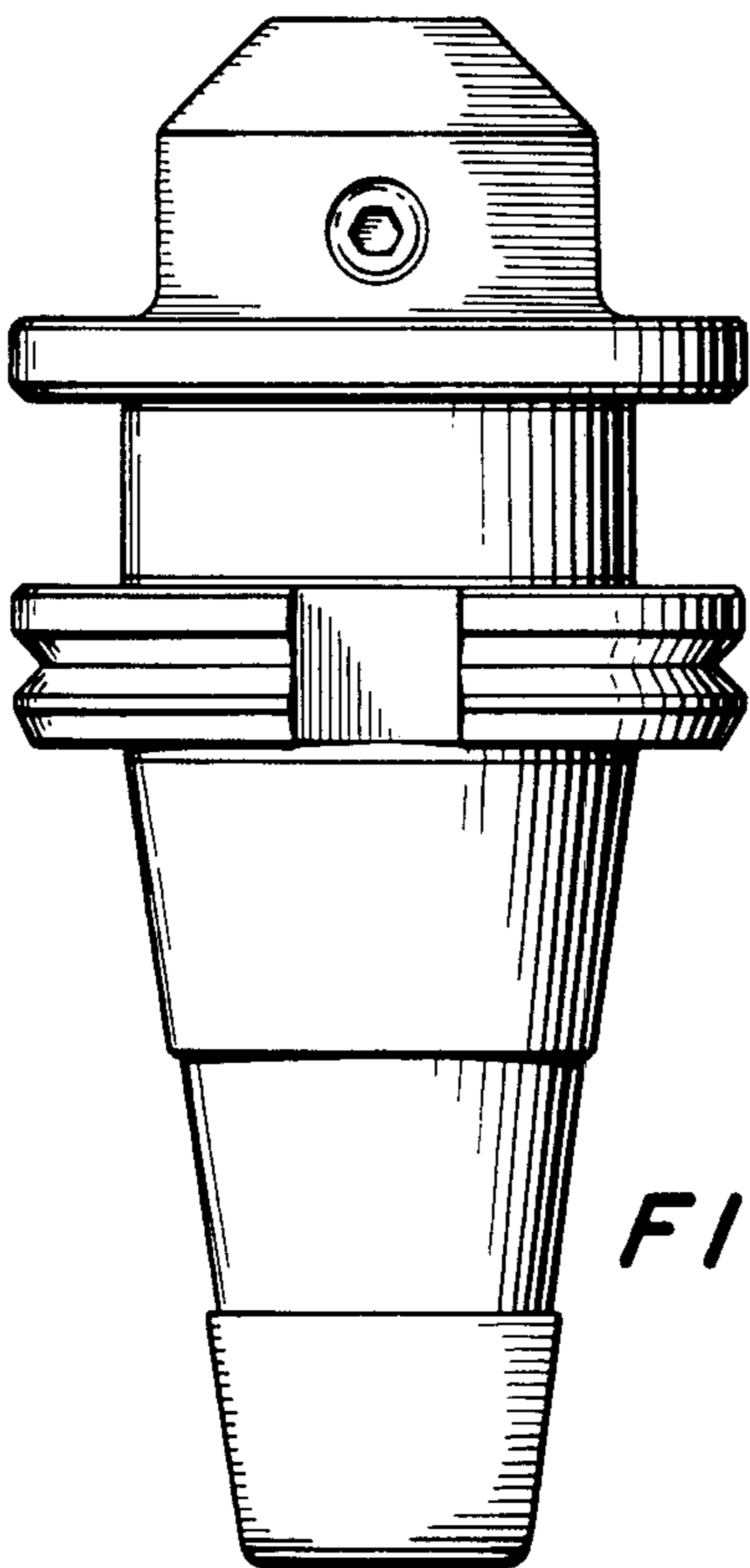

FIG. 2

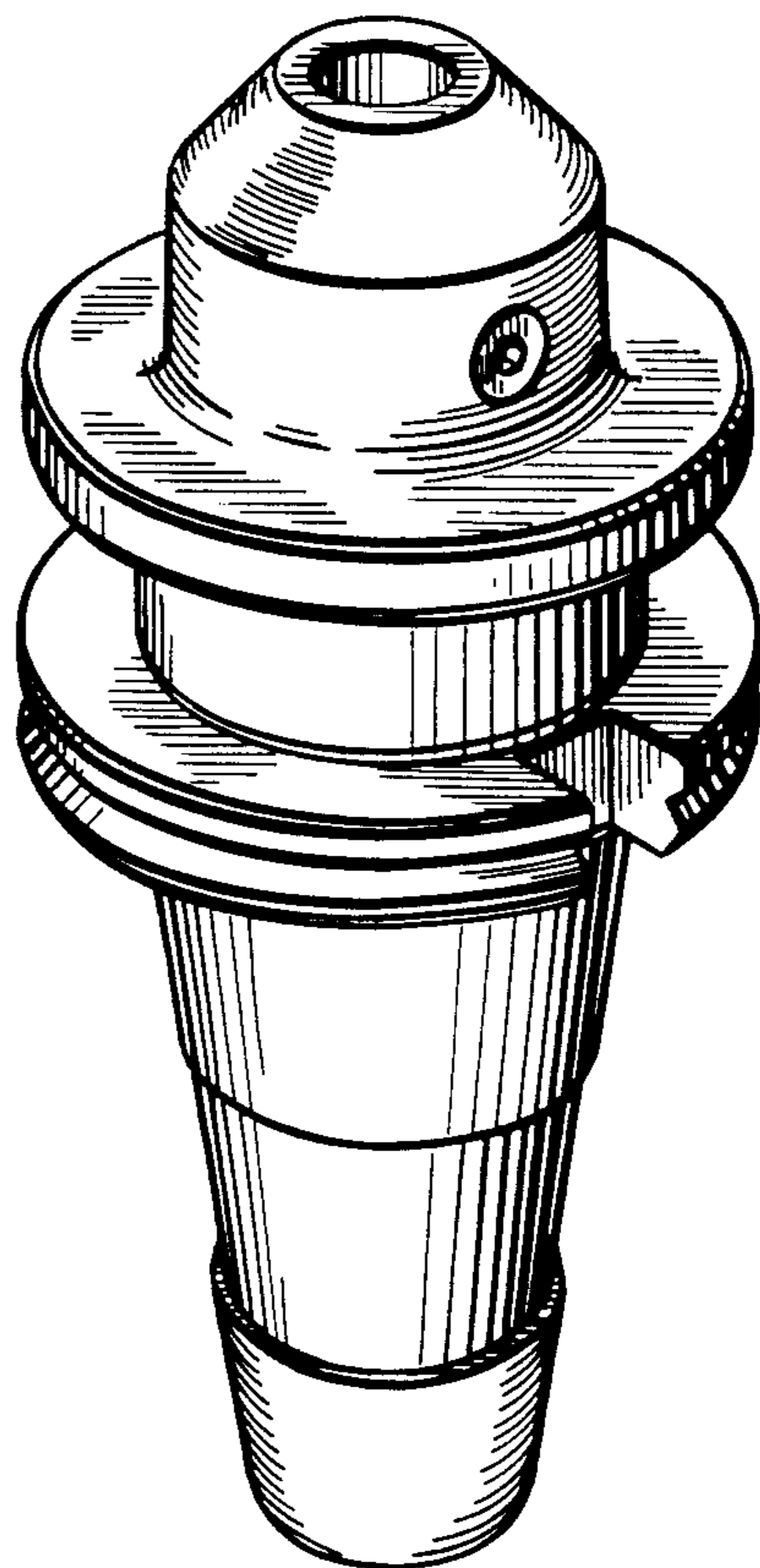

FIG. 1

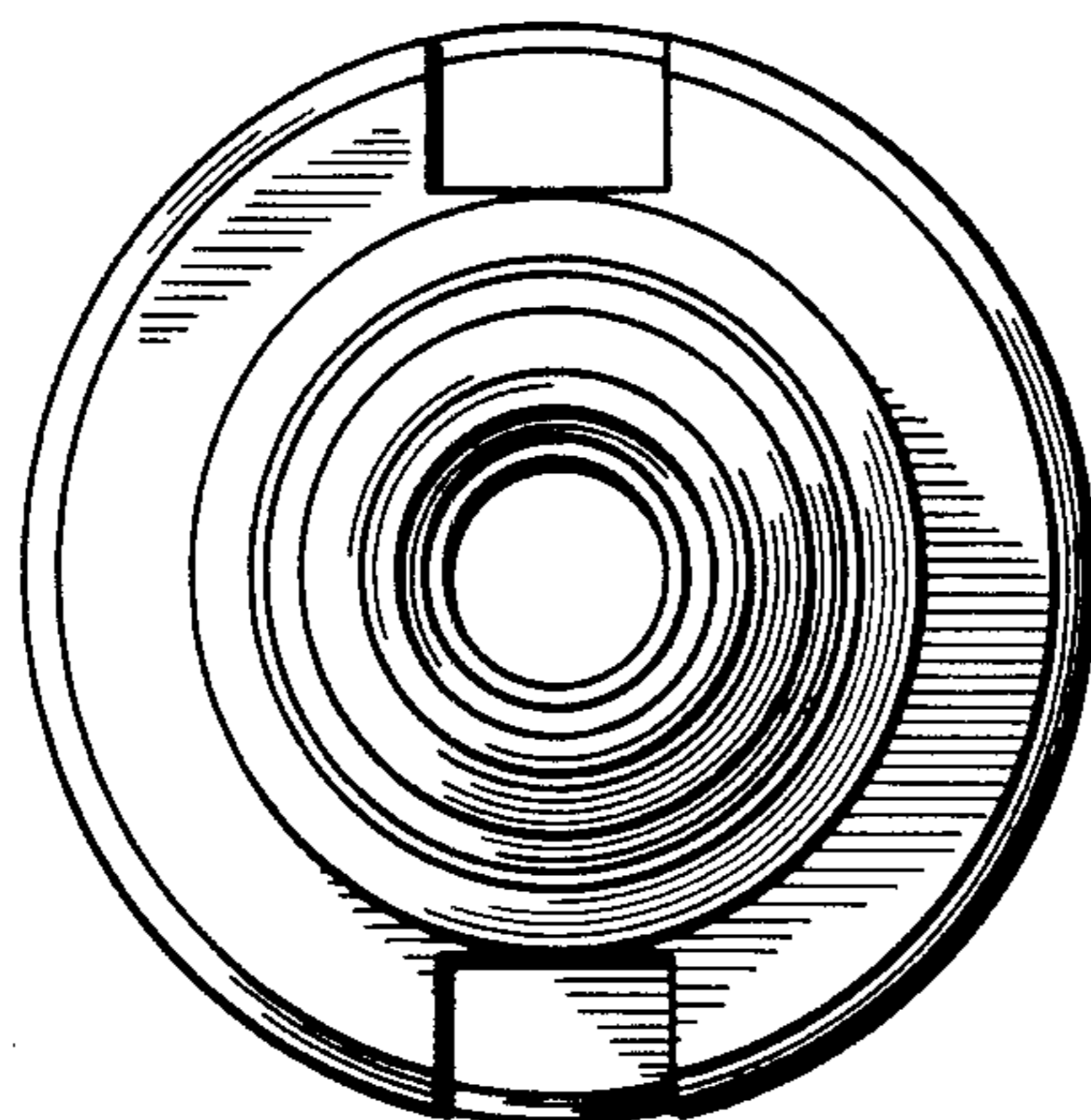

FIG. 4

FIG. 7

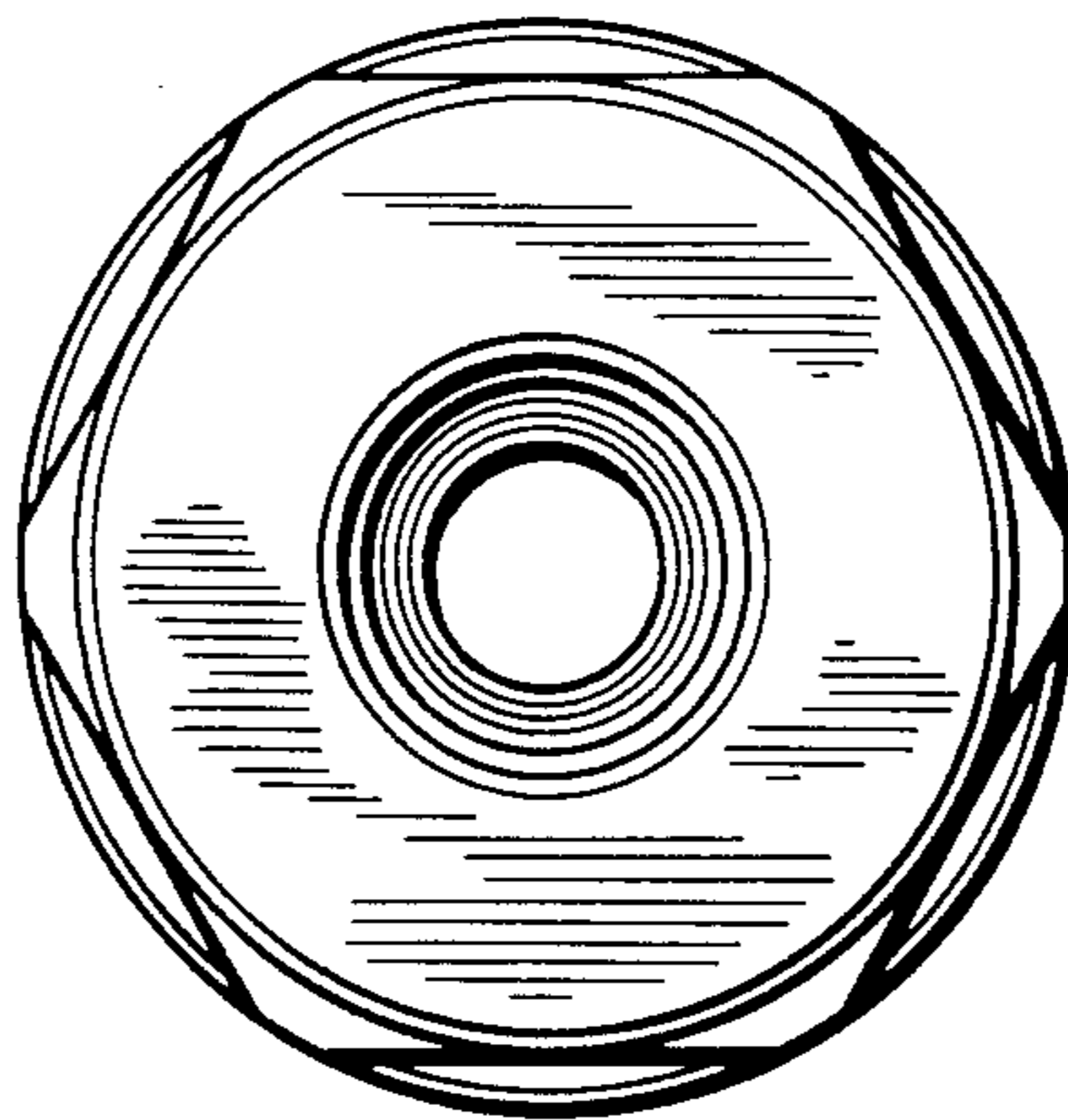

FIG. 6

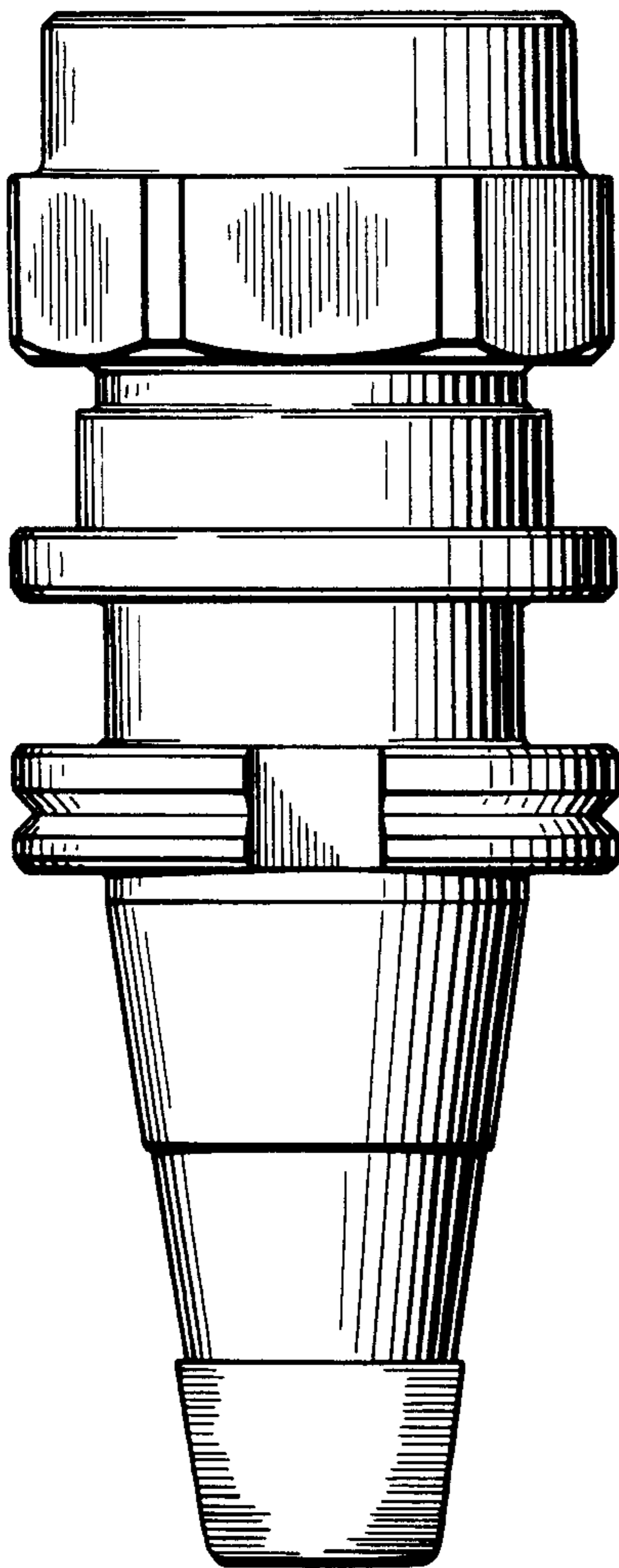

FIG. 5

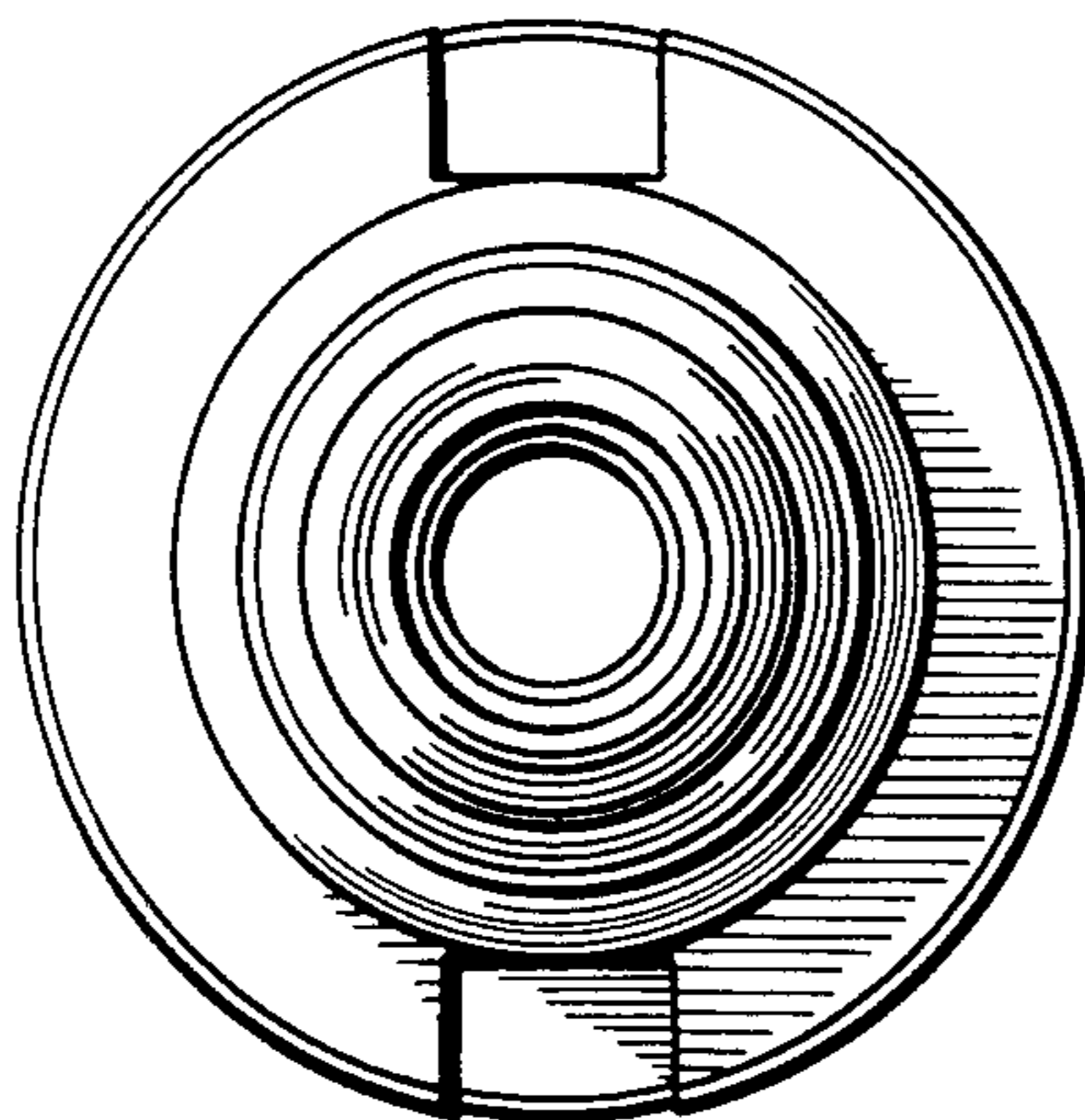
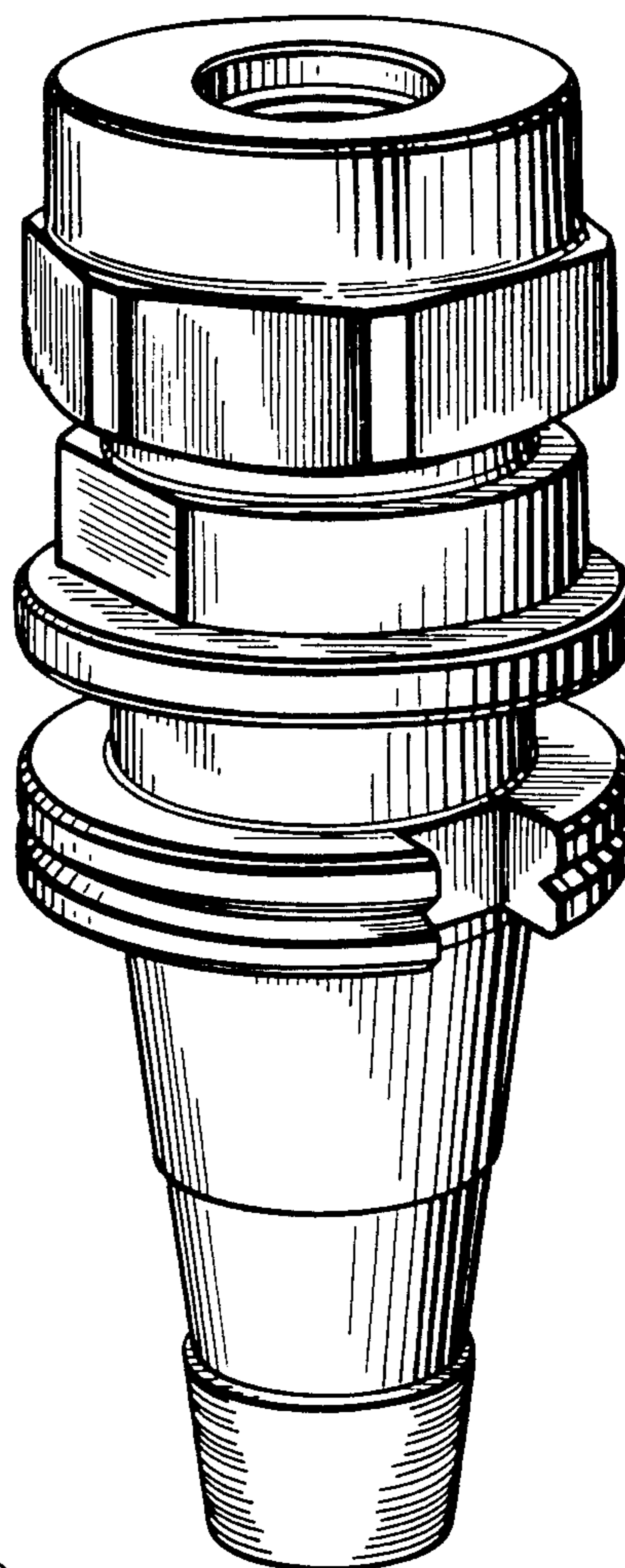

FIG. 8