

- [54] **AUTOMOBILE WHEEL**
- [75] Inventor: **Merlyn R. Reppert**, Torrance, Calif.
- [73] Assignee: **W. R. Grace & Co.**, New York, N.Y.
- [**] Term: **14 Years**
- [21] Appl. No.: **499,798**
- [22] Filed: **Aug. 22, 1974**

Related U.S. Application Data

- [63] Continuation-in-part of Ser. No. 375,311, July 2, 1973, abandoned.
- [51] Int. Cl. **D12-16**
- [52] U.S. Cl. **D12/211**
- [58] Field of Search **D12/206, 209-211; 301/6 CS, 90 N, 63 R, 64 R, 645 D, 65**

References Cited

U.S. PATENT DOCUMENTS

3,250,572	5/1966	Walker	301/65
3,346,304	10/1967	Fenton	D12/211
D. 204,933	5/1966	Richter	D12/211
D. 216,527	2/1970	Parker	D12/211
D. 216,687	3/1970	Reid	D12/211
D. 222,348	10/1971	Harty, Jr.	D12/211

OTHER PUBLICATIONS

Car and Driver, Feb. 1967, p. 48, Rally II Wheel, second box up from bottom left side of page.

Modern Tire Dealer, Mar. 1970, Inside Rear Cover Wheel, top right side of page.
 Modern Tire Dealer, June 1972, p. 58, Wheel, top right side of page.
 Sports Car Graphic, May 1968, p. 3, Wheel, bottom center of page.
 Motor Trend, Jan. 1973, p. 40, Wheel, center right side of page.

Primary Examiner—Wallace R. Burke
Assistant Examiner—James M. Gandy
Attorney, Agent, or Firm—Charles L. Harness

[57] **CLAIM**

The ornamental design for an automobile wheel, substantially as shown and described.

DESCRIPTION

FIG. 1 is a side elevation view of the automobile wheel showing my new design;
 FIG. 2 is an end elevation view thereof;
 FIG. 3 is a side elevation view thereof taken from the side opposite to that of FIG. 1; and
 FIG. 4 is an enlarged cross sectional view thereof taken along the line 4-4 in FIG. 1
 FIG. 5 is a side elevation view of the automobile wheel showing a second embodiment of my new design;
 FIG. 6 is an end elevation view of FIG. 5;
 FIG. 7 is a side elevation view of the side opposite to that shown in FIG. 5; and
 FIG. 8 is an enlarged cross sectional view taken along the line 8-8 in FIG. 5.

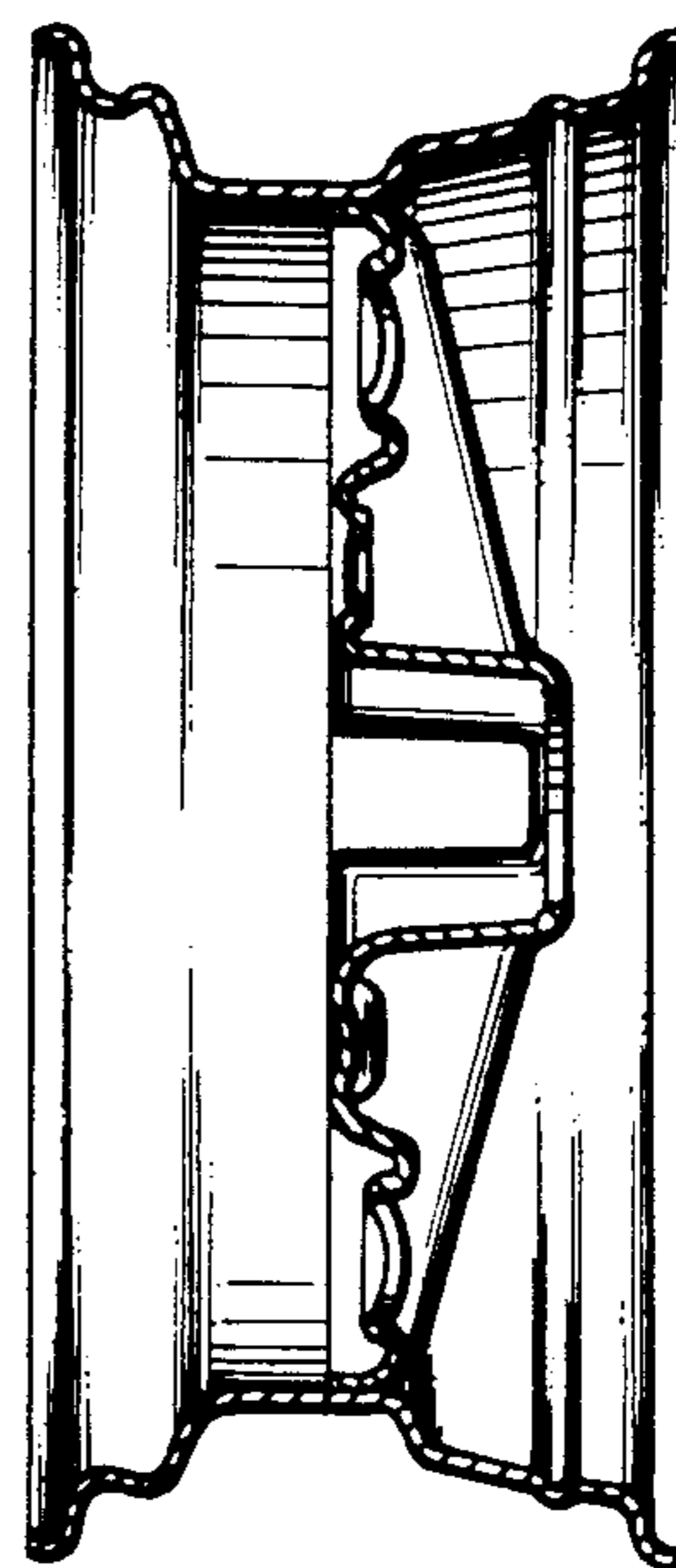
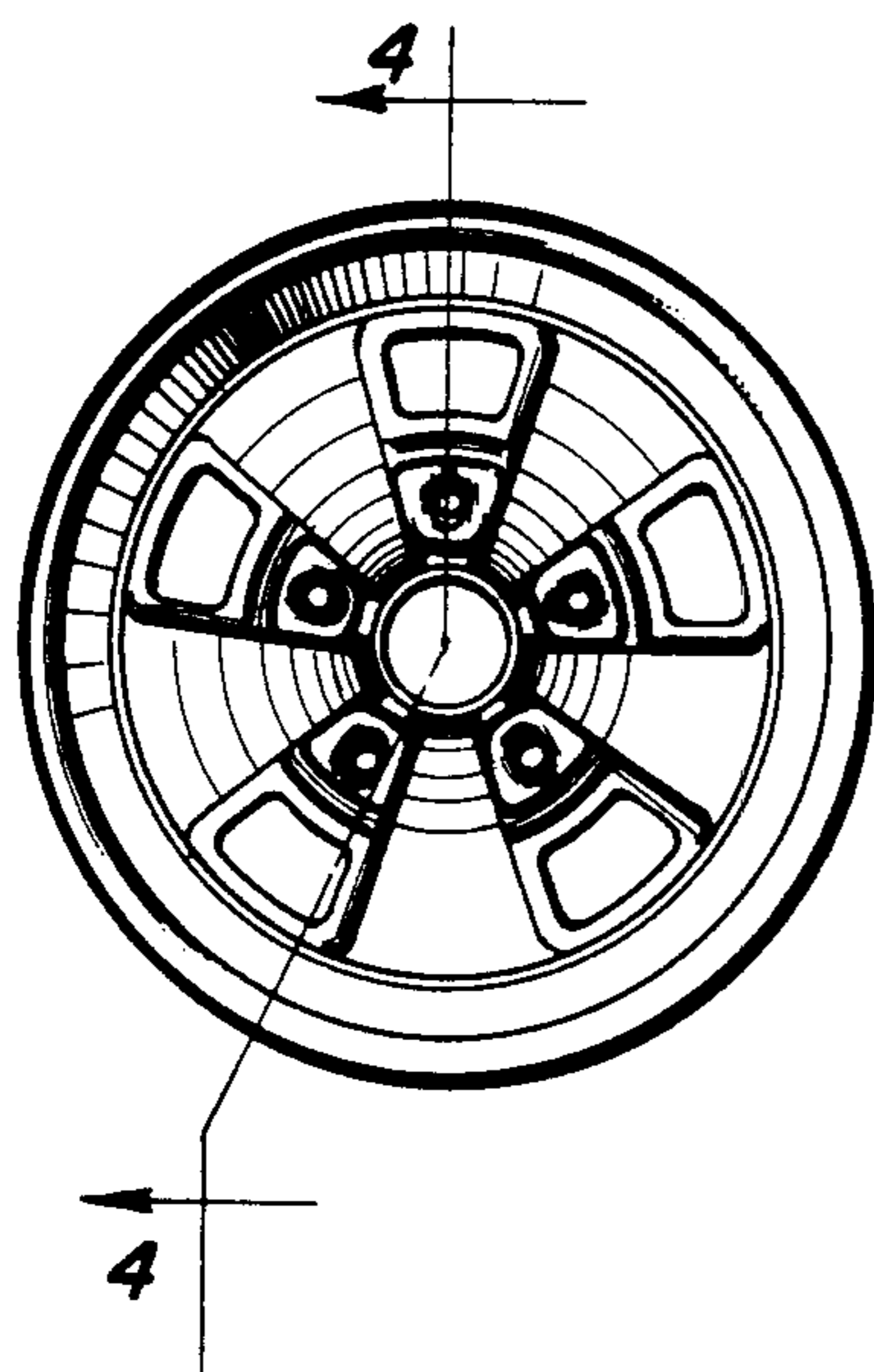

FIG. 1

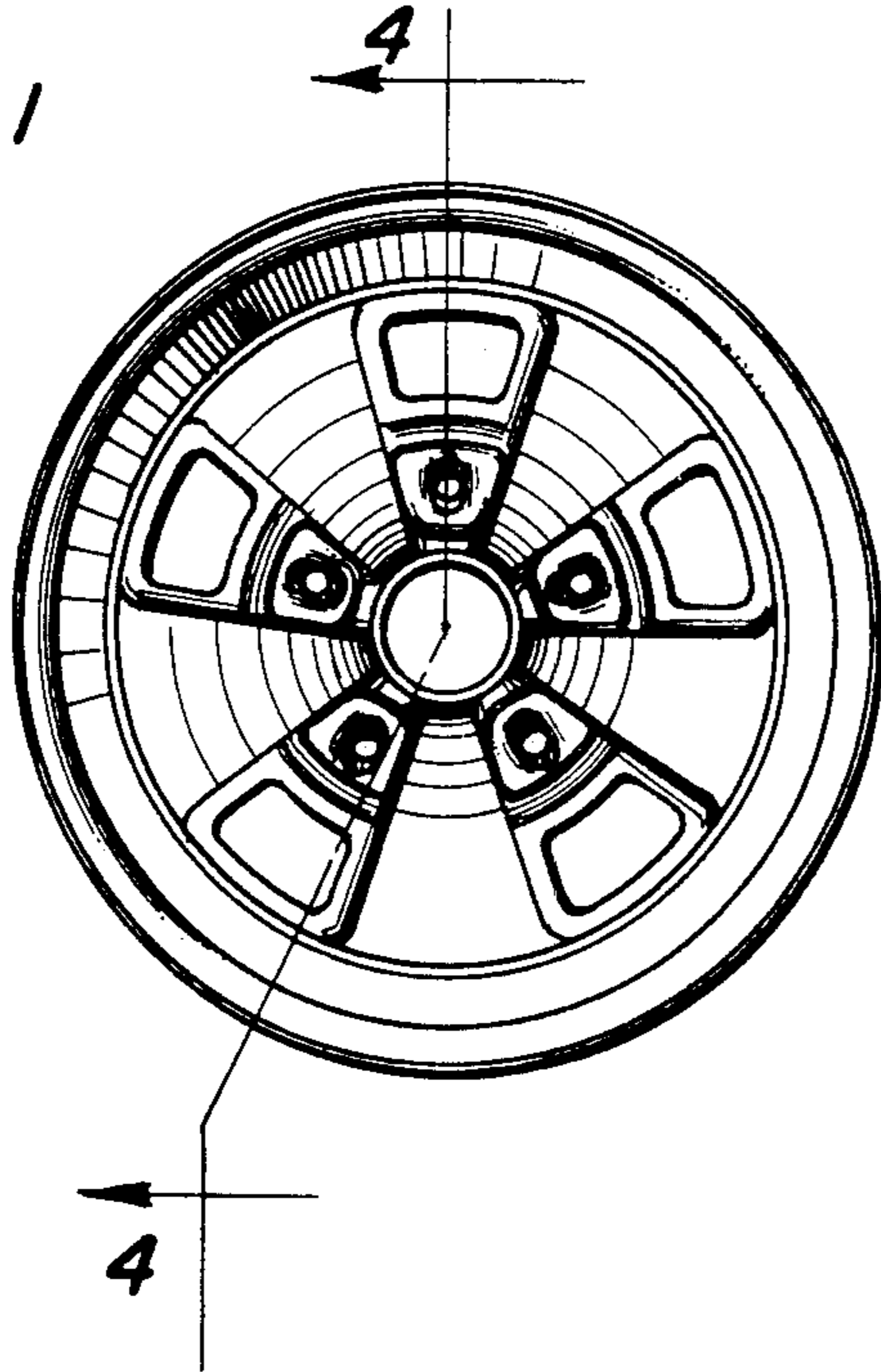

FIG. 2



FIG. 4

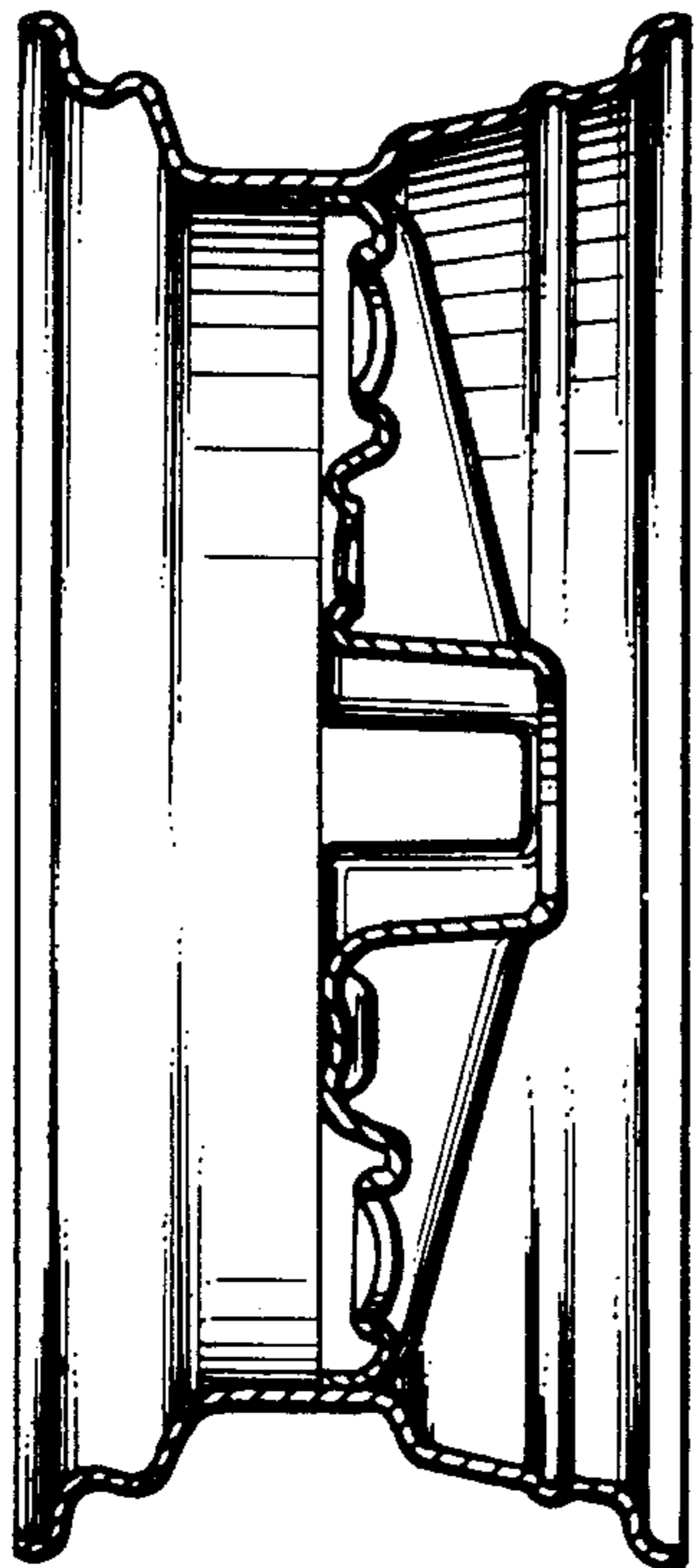
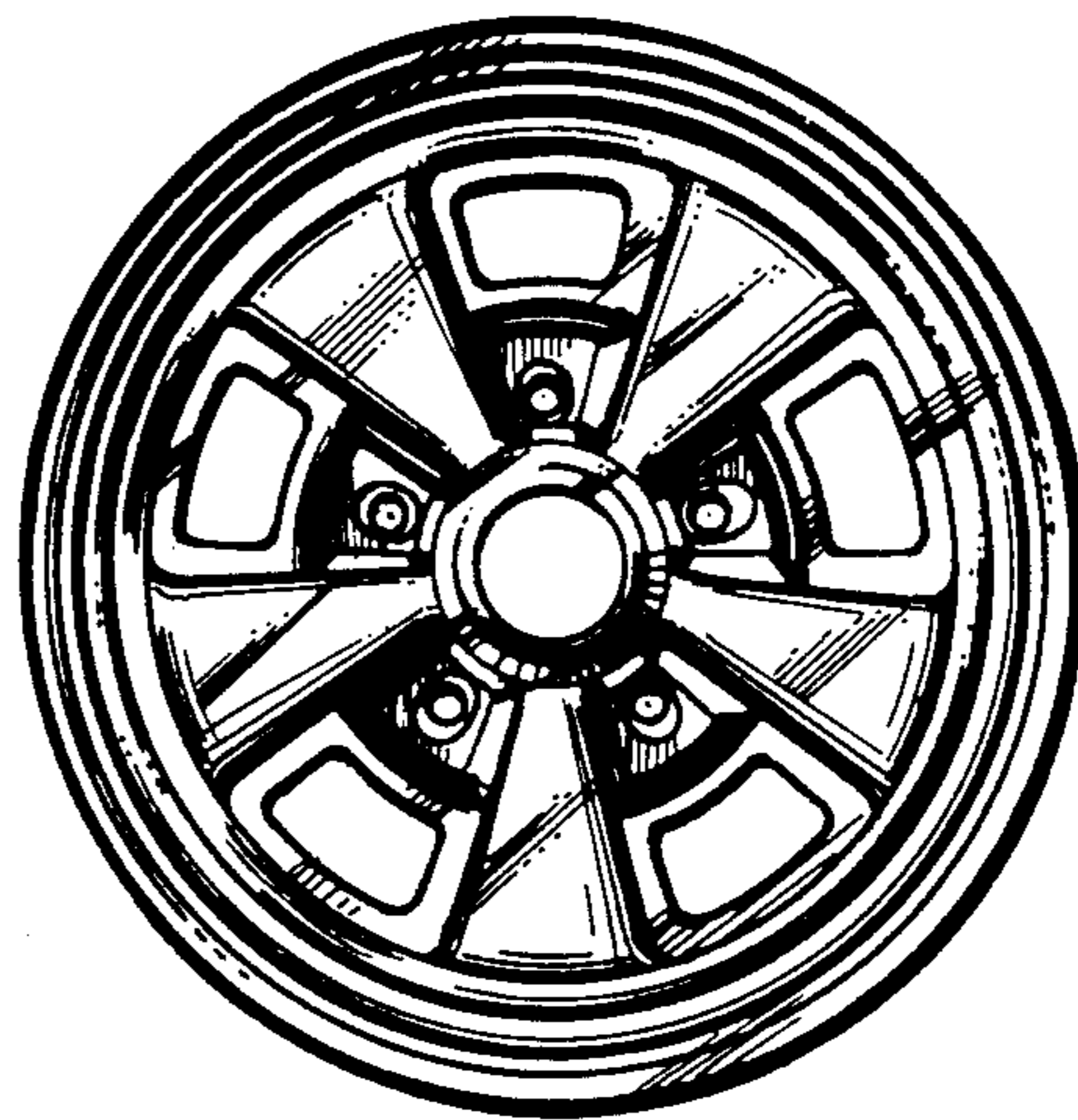

FIG. 3



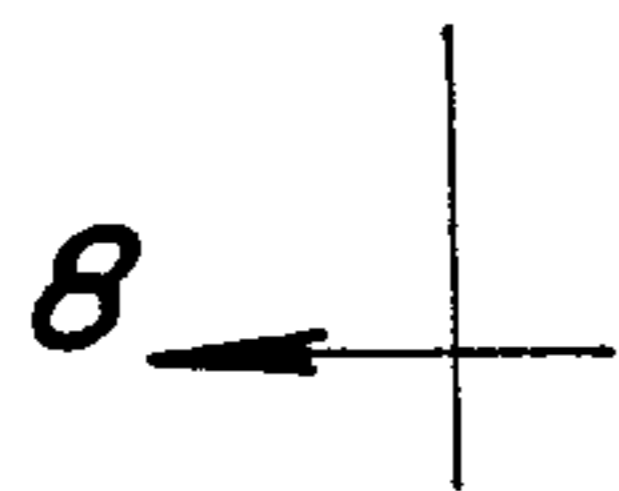
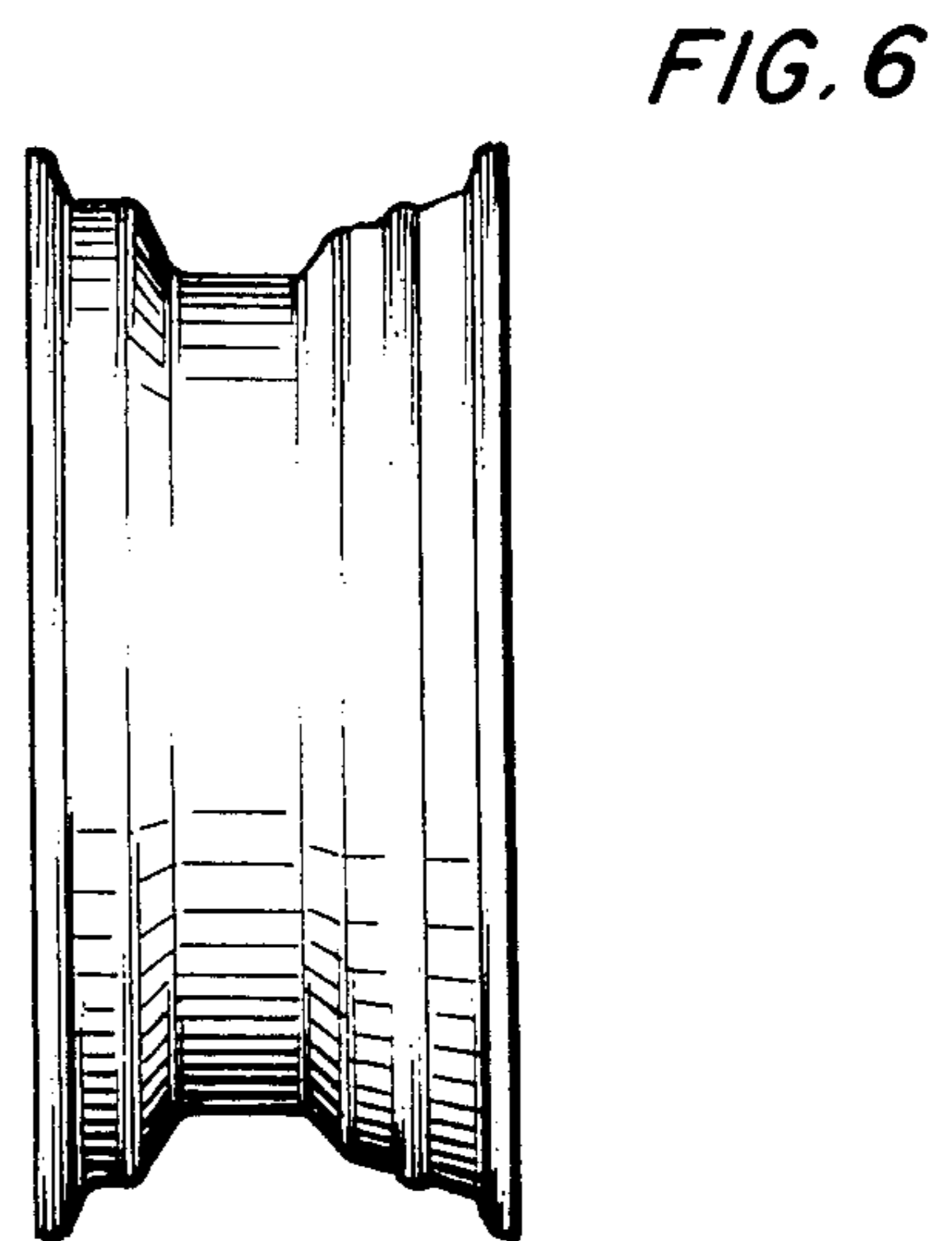
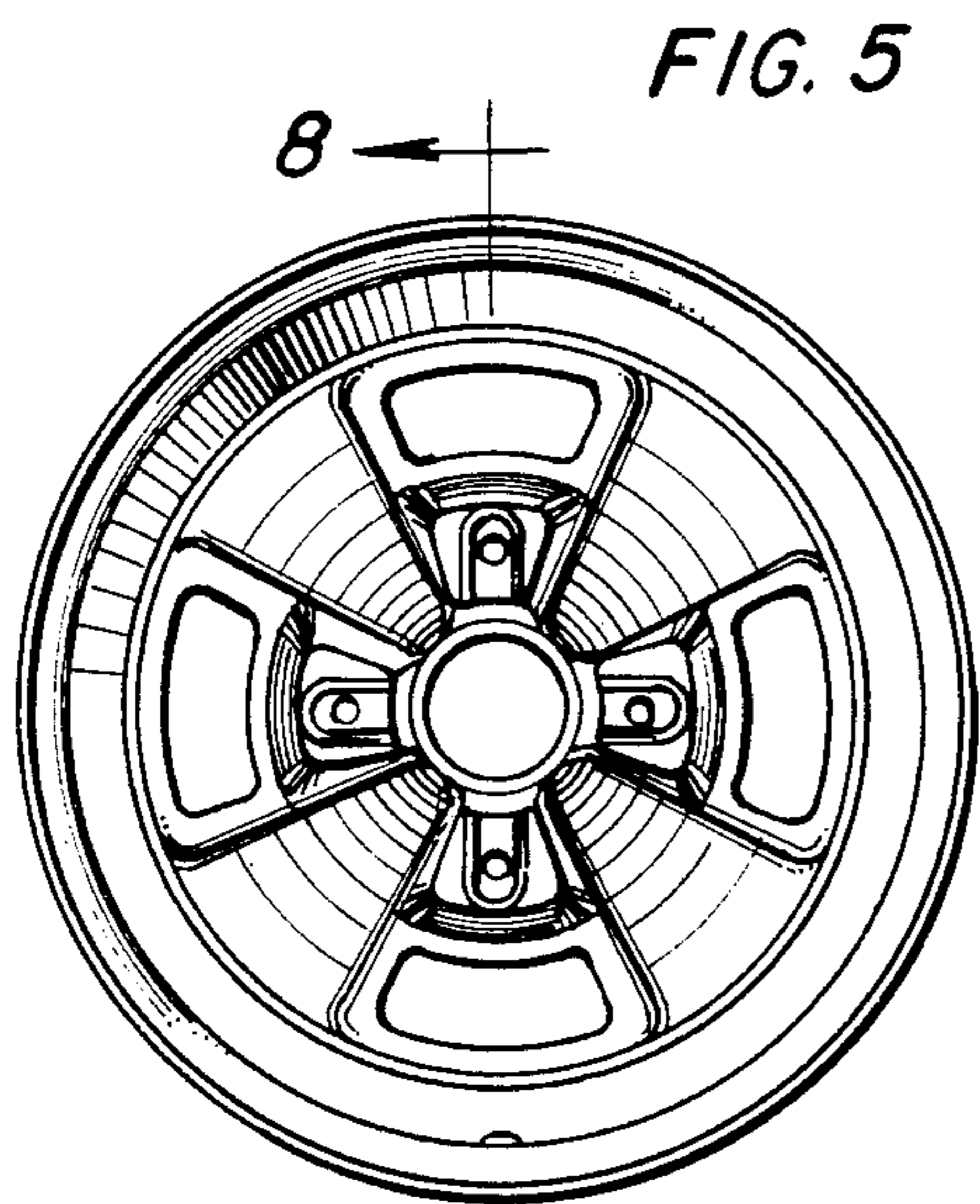

FIG. 8

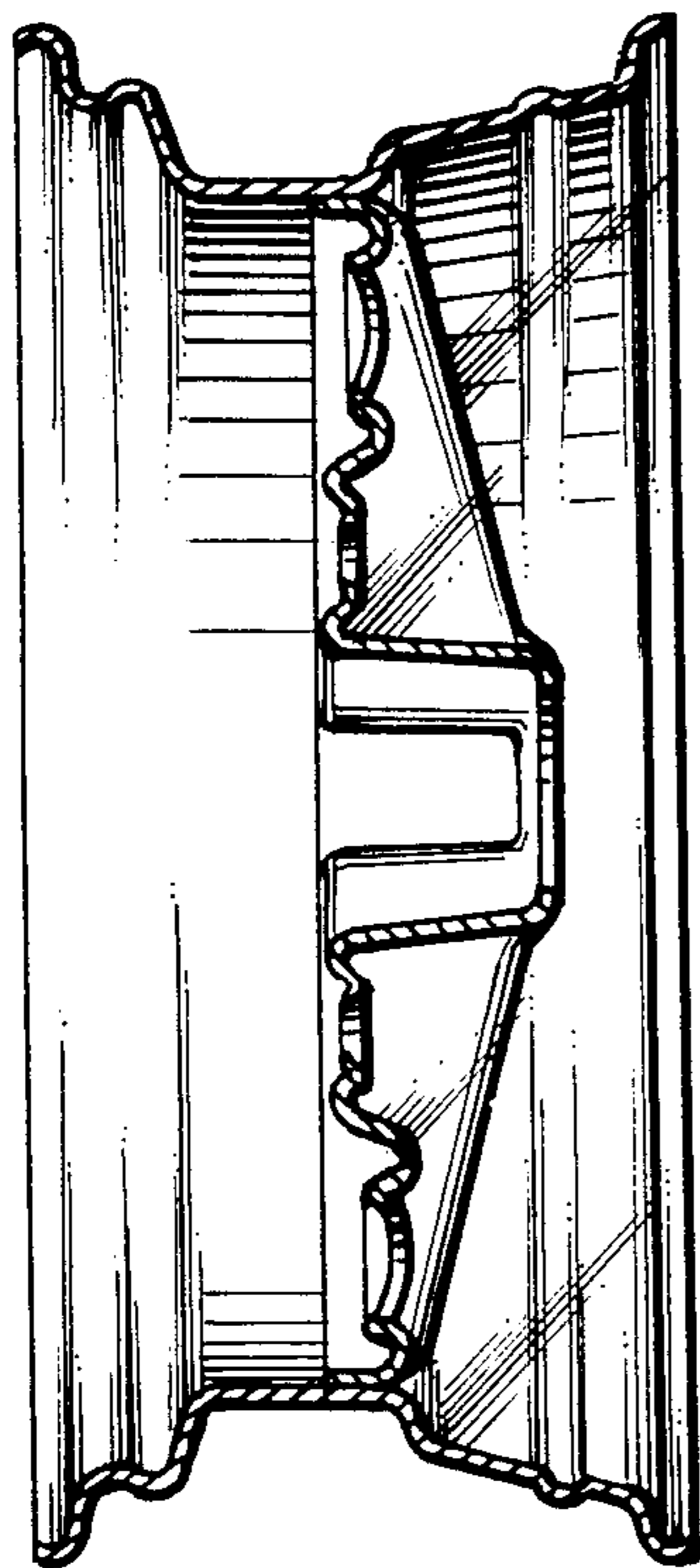

FIG. 7

