

[54] AIRCRAFT

[75] Inventor: **Waldo Virgil Opfer**, San Diego County, Calif.

[73] Assignee: **Teledyne Ryan Aeronautical a Division of Teledyne Industries, Inc.**, San Diego, Calif.

[\*\*] Term: **14 Years**

[21] Appl. No.: **604,631**

[22] Filed: **Aug. 14, 1975**

[51] Int. Cl. .... **D12-07**

[52] U.S. Cl. .... **D12/71**

[58] Field of Search ..... **D12/71; 244/15, 36, 244/46, 48, 45 R, 45 A**

[56] **References Cited**

**U.S. PATENT DOCUMENTS**

D. 177,500 4/1956 Heinemann et al. .... D12/71  
D. 196,343 9/1963 Norman et al. .... D12/71

*Primary Examiner*—Alan P. Douglas  
*Attorney, Agent, or Firm*—Carl R. Brown

[57] **CLAIM**

The ornamental design for an aircraft, substantially as shown.

**DESCRIPTION**

FIG. 1 is a perspective view of an aircraft, showing my new design;

FIG. 2 is a top plan view thereof;

FIG. 3 is a side elevational view thereof;

FIG. 4 is a front elevational view thereof;

FIG. 5 is a bottom plan view thereof; and

FIG. 6 is a rear elevational view thereof.

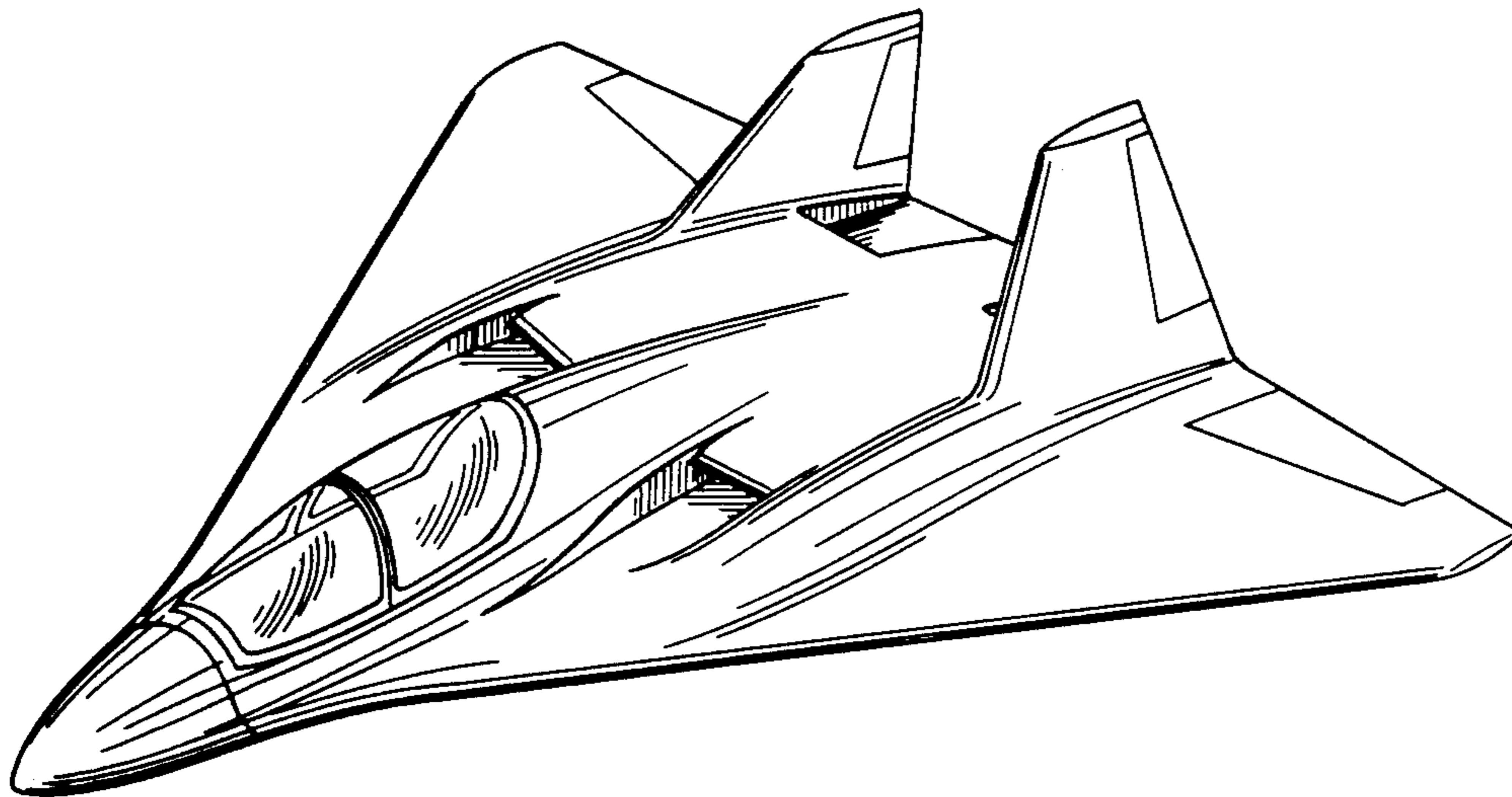

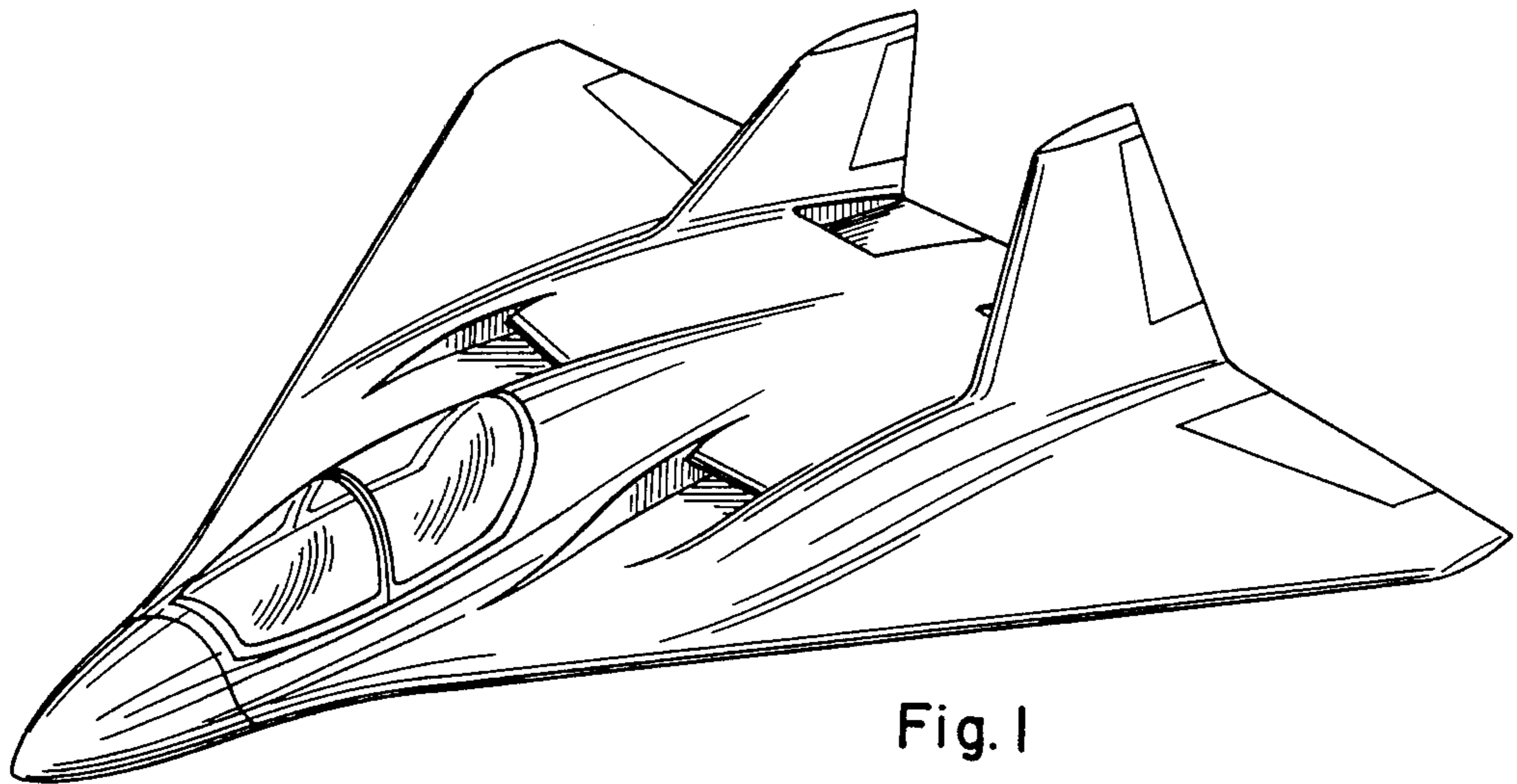

Fig. 1

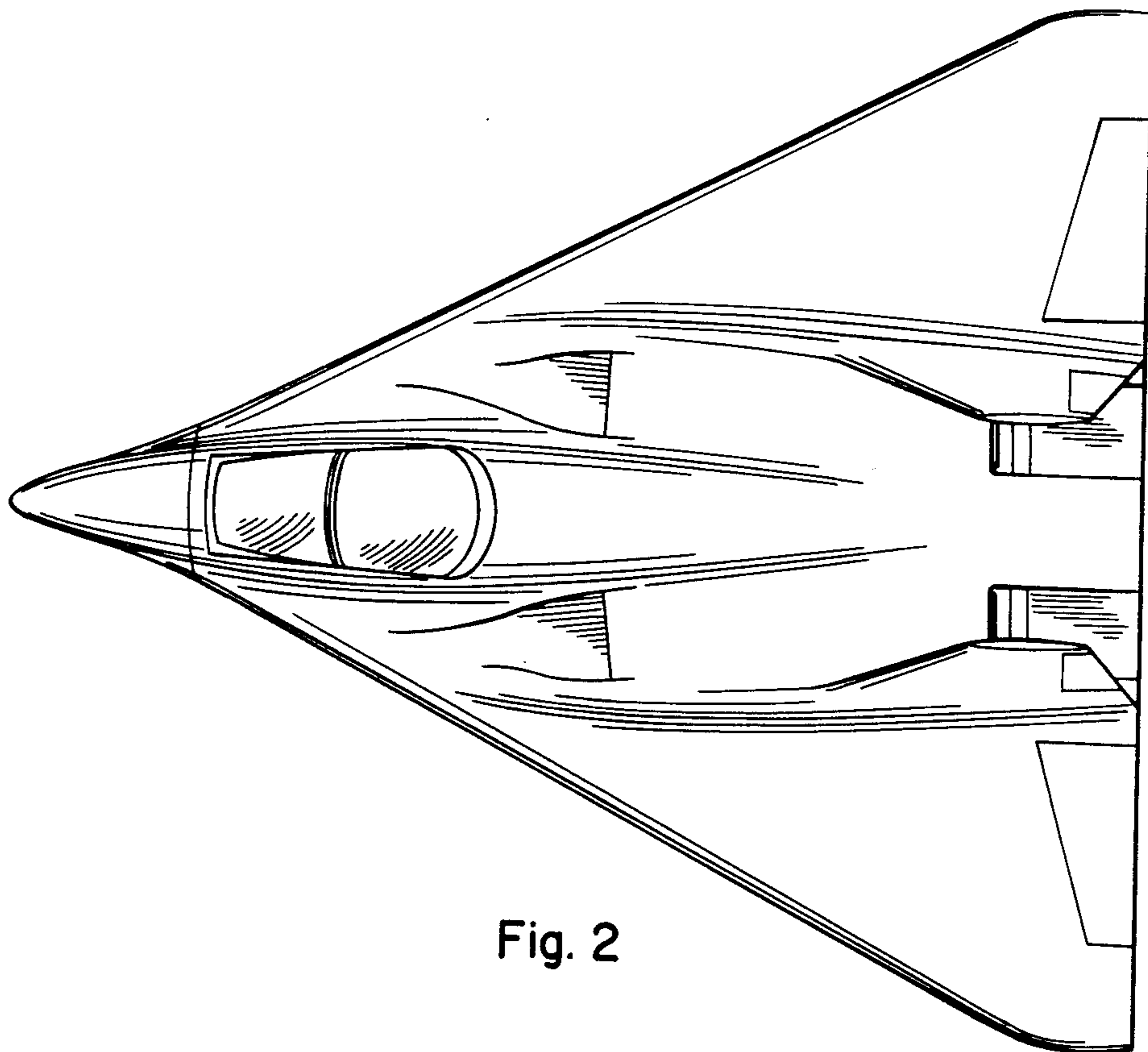

Fig. 2

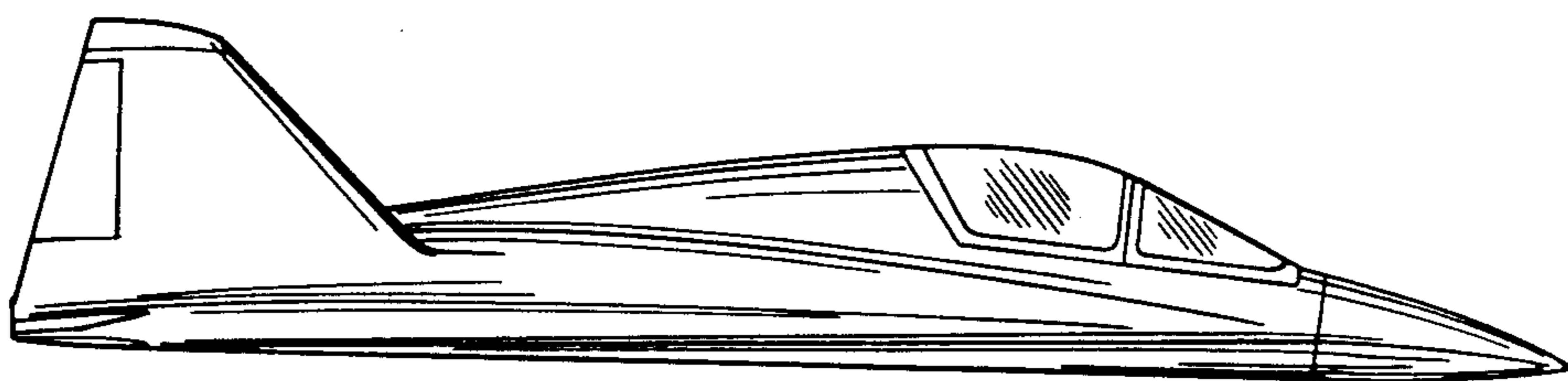

Fig. 3

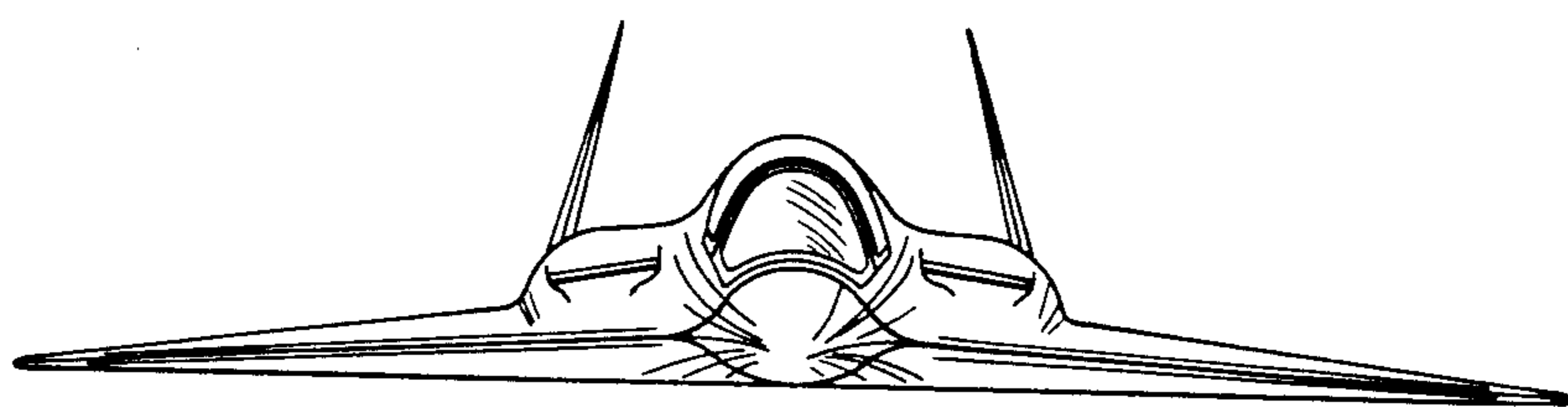

Fig. 4

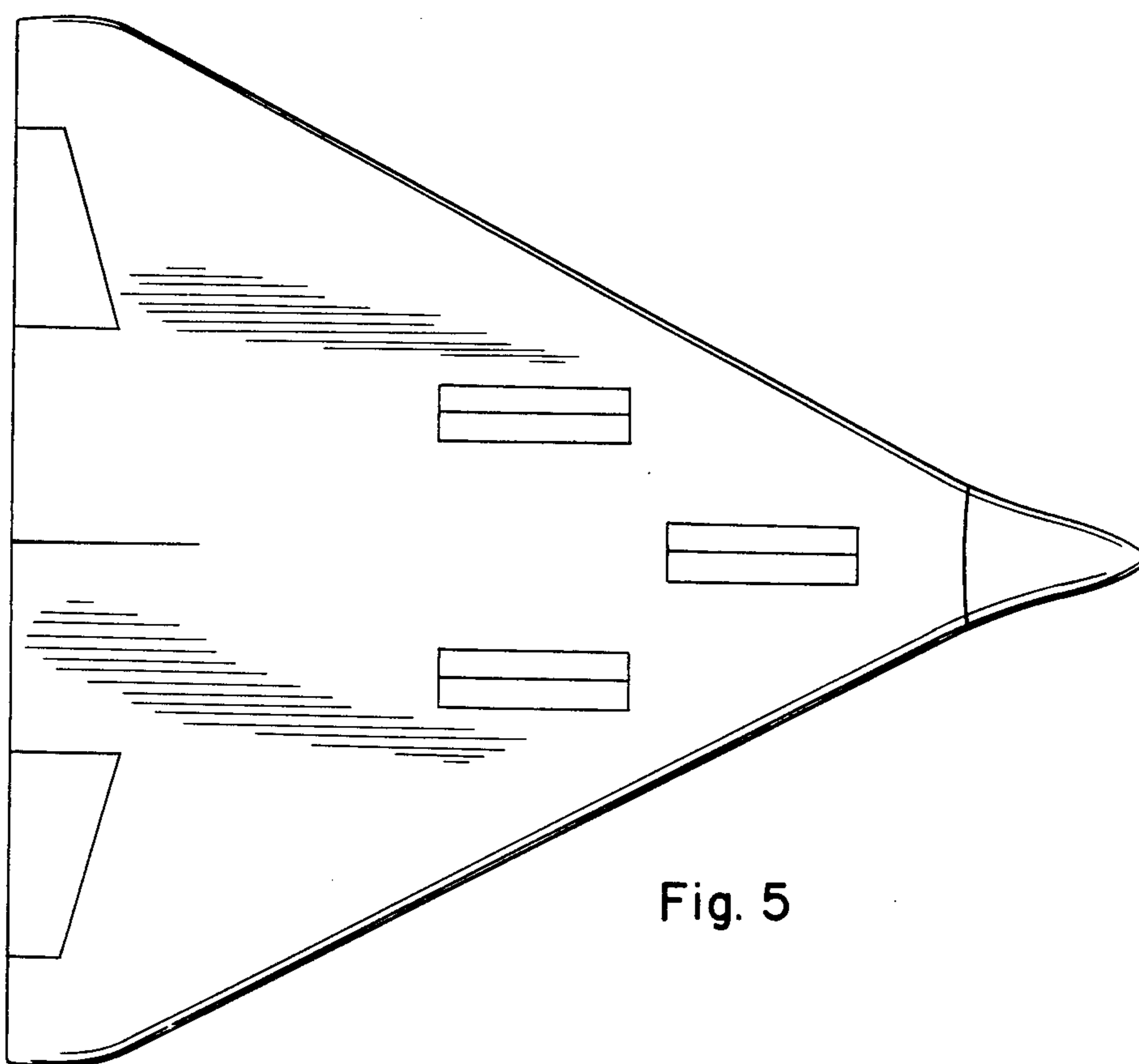

Fig. 5

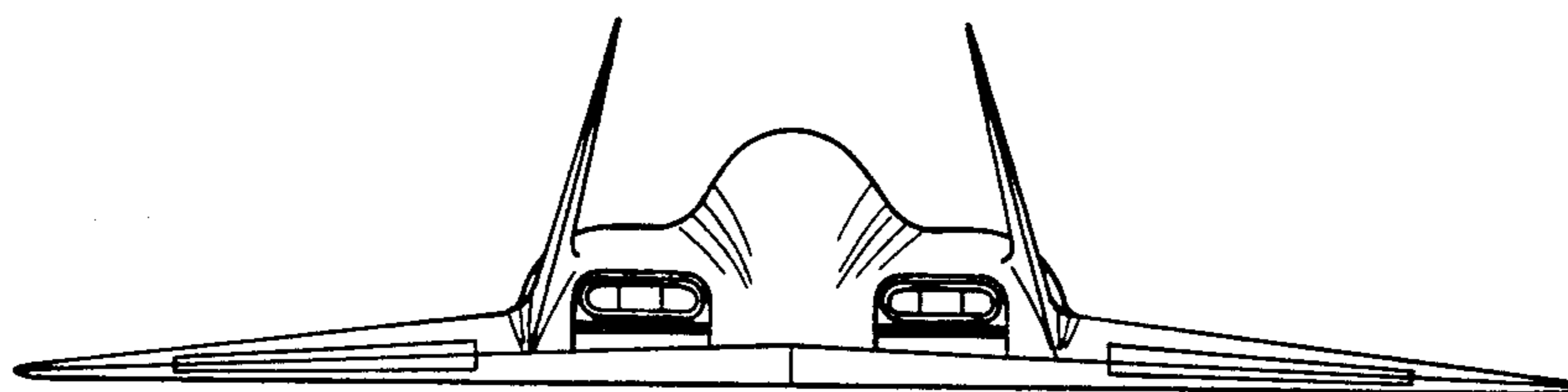

Fig. 6