

[54] MODULAR SOUND SYSTEM FOR MUSICAL INSTRUMENTS WITH ELECTRIC PICKUPS

[75] Inventor: Laurence Anthony Macari, Chorley Wood, England

[73] Assignee: Macari's Limited, London, England

[**] Term: 14 Years

[21] Appl. No.: 669,977

[22] Filed: Mar. 24, 1976

[30] Foreign Application Priority Data

Feb. 13, 1976 United Kingdom 974458/76

[51] Int. Cl. D14-03

[52] U.S. Cl. D14/96

[58] Field of Search 84/1, 1.15, 1.28, 1.17, 84/1.04; D26/14 L

[56] References Cited

U.S. PATENT DOCUMENTS

D. 236,212 8/1975 Beigel et al. D26/14 L

OTHER PUBLICATIONS

Grossman Music Corp., Cat. 68, 1968, p. 467, Kent 6400 Distorter.

Lafayette Electronics, 1974, Cat. No. 750, p. 116, Lafayette "Fuzz" Sound, Item No. 1.

Primary Examiner—Bernard Ansher

[57] CLAIM

The ornamental design for a modular sound system for musical instruments with electric pickups, as shown and described.

DESCRIPTION

FIG. 1 is a front elevation of a modular sound system for musical instruments and electric pickups showing my new design;

FIG. 2 is a top plan view;

FIG. 3 is a bottom plan view;

FIG. 4 is a side elevation, the opposite being a mirror image of the side shown;

FIG. 5 is a front perspective view thereof; and

FIG. 6 is a rear perspective thereof.

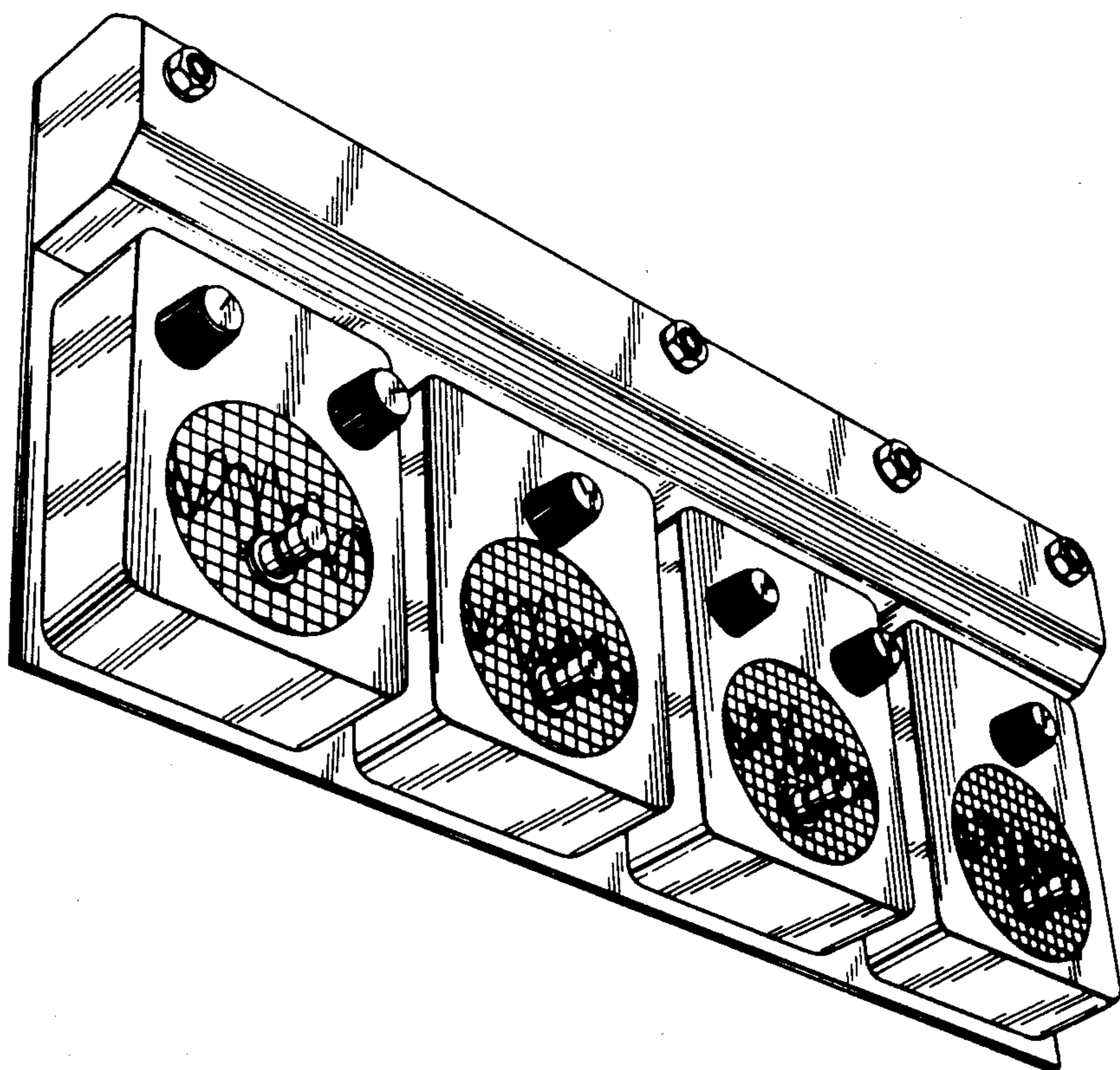
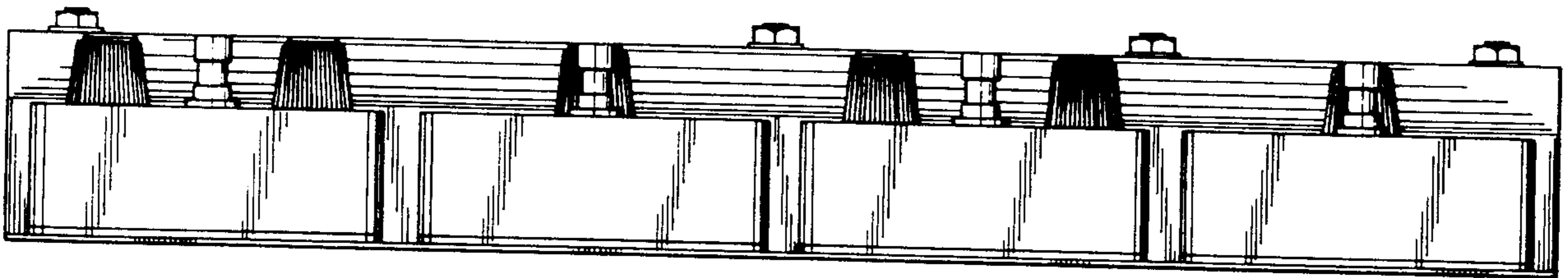

FIG. 1.

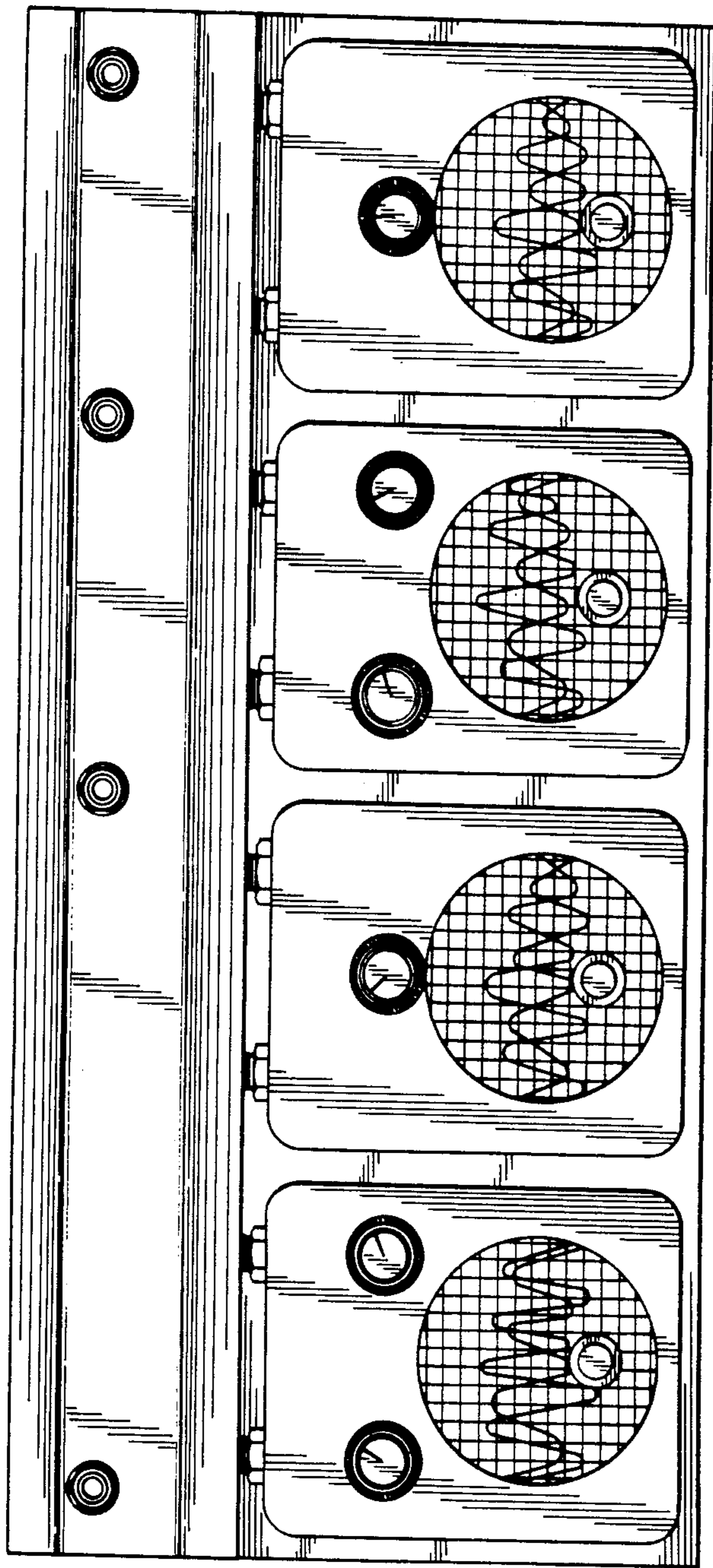

FIG. 2

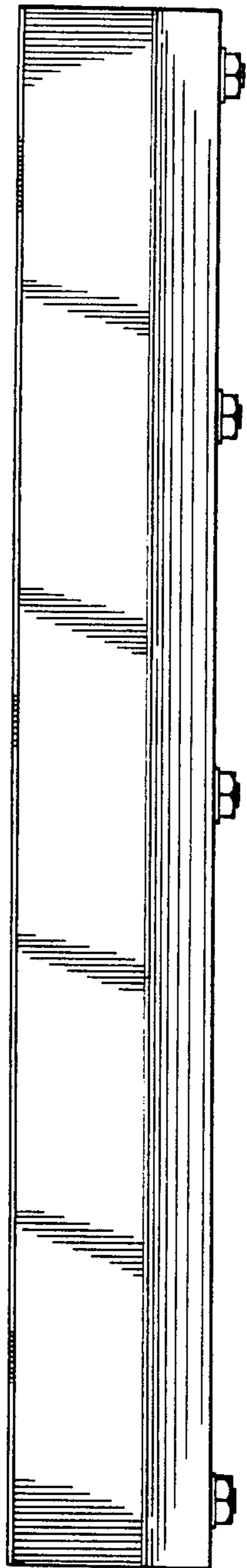

FIG. 3

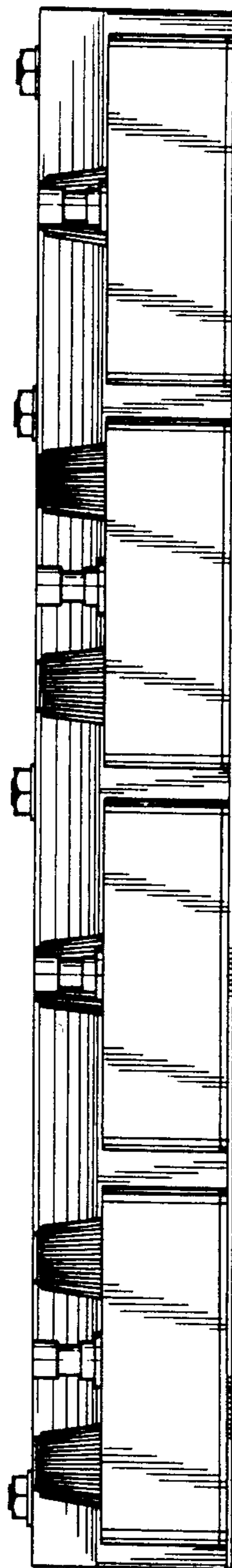
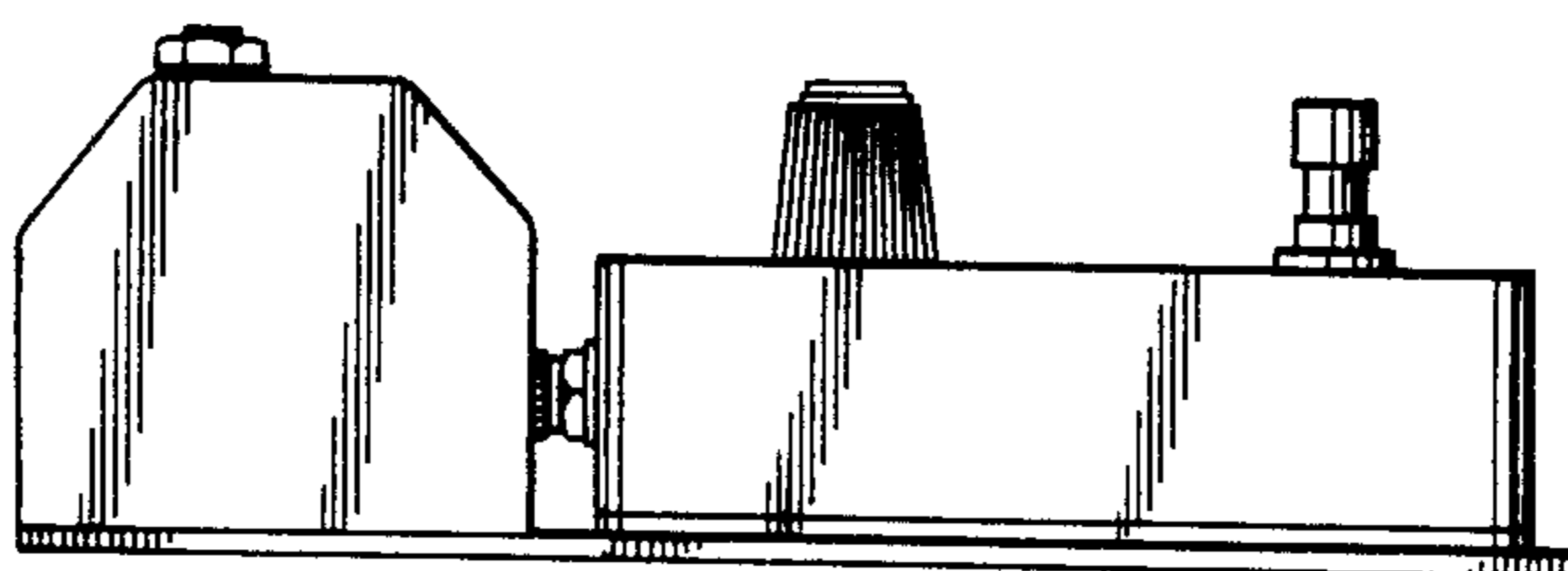

FIG. 4



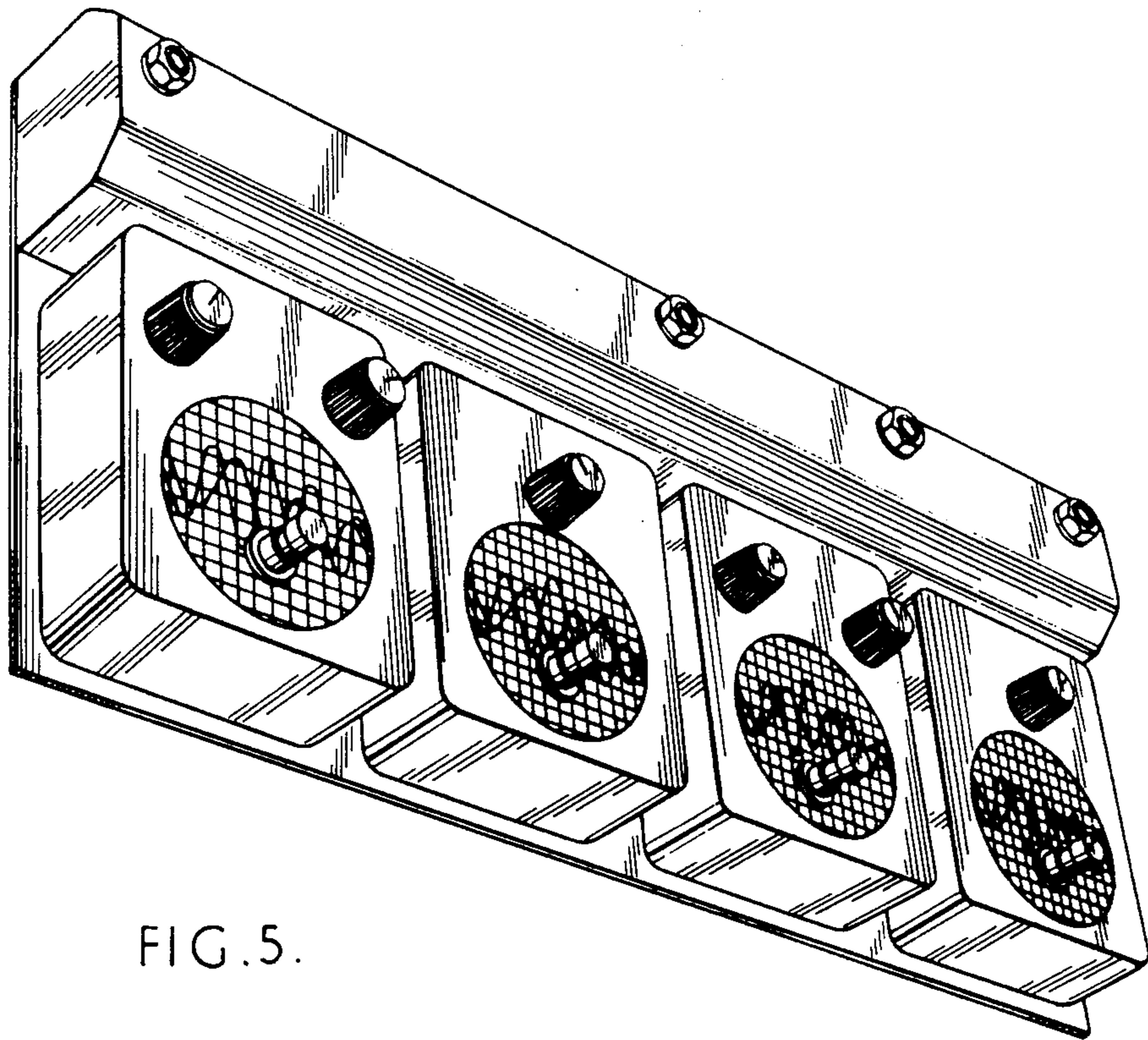

FIG. 5.

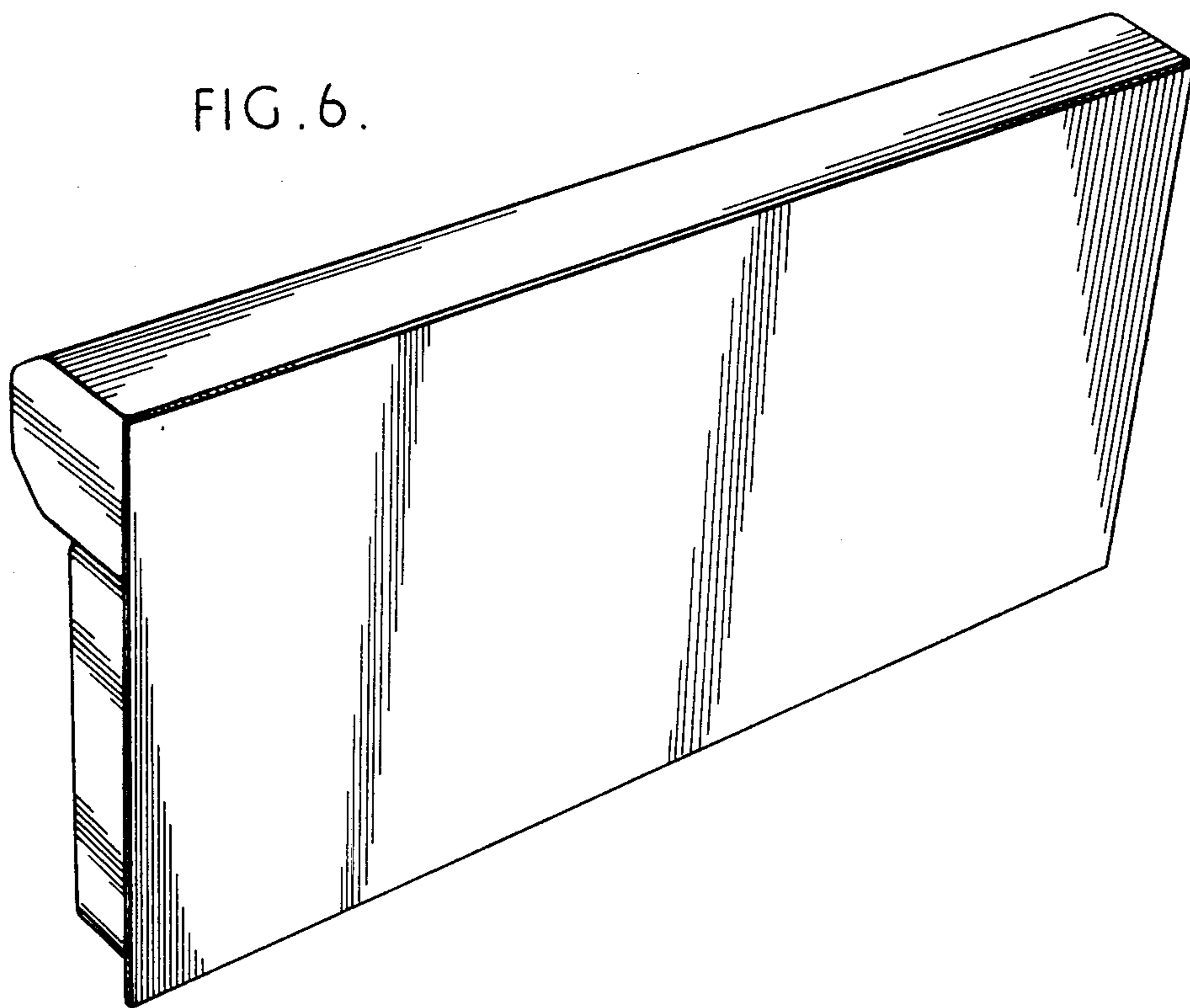

FIG. 6.