

[54] **SEAT**

[75] **Inventor:** Giovanni Offredi, Milan, Italy

[73] **Assignee:** Fratelli Saporiti, Besnate (Varese), Italy

[**] **Term:** 14 Years

[21] **Appl. No.:** 559,450

[22] **Filed:** Mar. 18, 1975

[30] **Foreign Application Priority Data**

Sept. 19, 1974 Italy 60913/74
 Sept. 19, 1974 Italy 60914/74
 Sept. 19, 1974 Italy 60915/74

[51] **Int. Cl.** D6-01

[52] **U.S. Cl.** D6/66

[58] **Field of Search** D6/37-39,
 D6/47-78

[56] **References Cited**

U.S. PATENT DOCUMENTS

D. 179,767 2/1957 Geva D6/47
 D. 188,488 8/1960 Otto D6/47
 D. 206,435 12/1966 Rodrigo D6/71

OTHER PUBLICATIONS

Interiors, Dec. 1958, p. 120, Panel 5, Chair.

Primary Examiner—Bruce W. Dunkins

Attorney, Agent, or Firm—William D. Denson

[57] **CLAIM**

The ornamental design for a seat, substantially as shown.

DESCRIPTION

FIG. 1 is a perspective view looking from the front of a chair embodying the present design;

FIG. 2 is a perspective view of the chair of FIG. 1 looking from above and to the front of said chair;

FIG. 3 is a perspective view of said chair looking from the rear and a side thereof;

FIG. 4 is a perspective view similar to FIG. 2 of a modified chair embodying the design;

FIG. 5 is a perspective view of the chair of FIG. 4 looking from the front and a side thereof;

FIG. 6 is a perspective view looking from the rear and a side thereof;

FIG. 7 is a perspective view of a loveseat embodying the present design;

FIG. 8 is a perspective view of the loveseat of FIG. 7 looking from the front thereof;

FIG. 9 is a view similar to FIG. 8 of a three-cushion sofa embodying the present design;

FIG. 10 is a perspective view of the sofa of FIG. 9 looking from a side and the rear thereof;

FIG. 11 is a perspective view similar to FIG. 9 of a four-cushion sofa embodying the present design; and

FIG. 12 is a perspective view looking from the rear and a side of the sofa of FIG. 11.

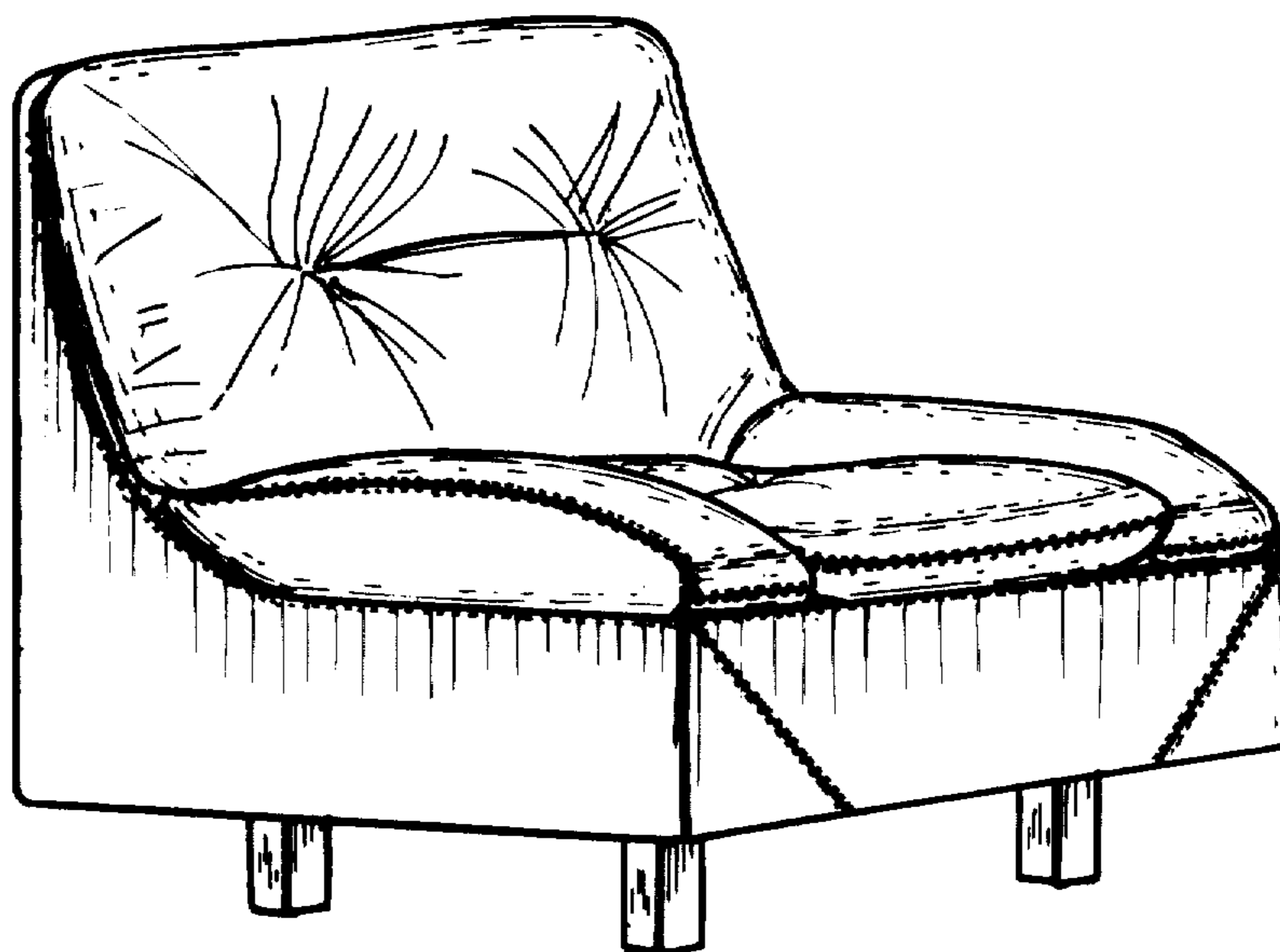

FIG. 1

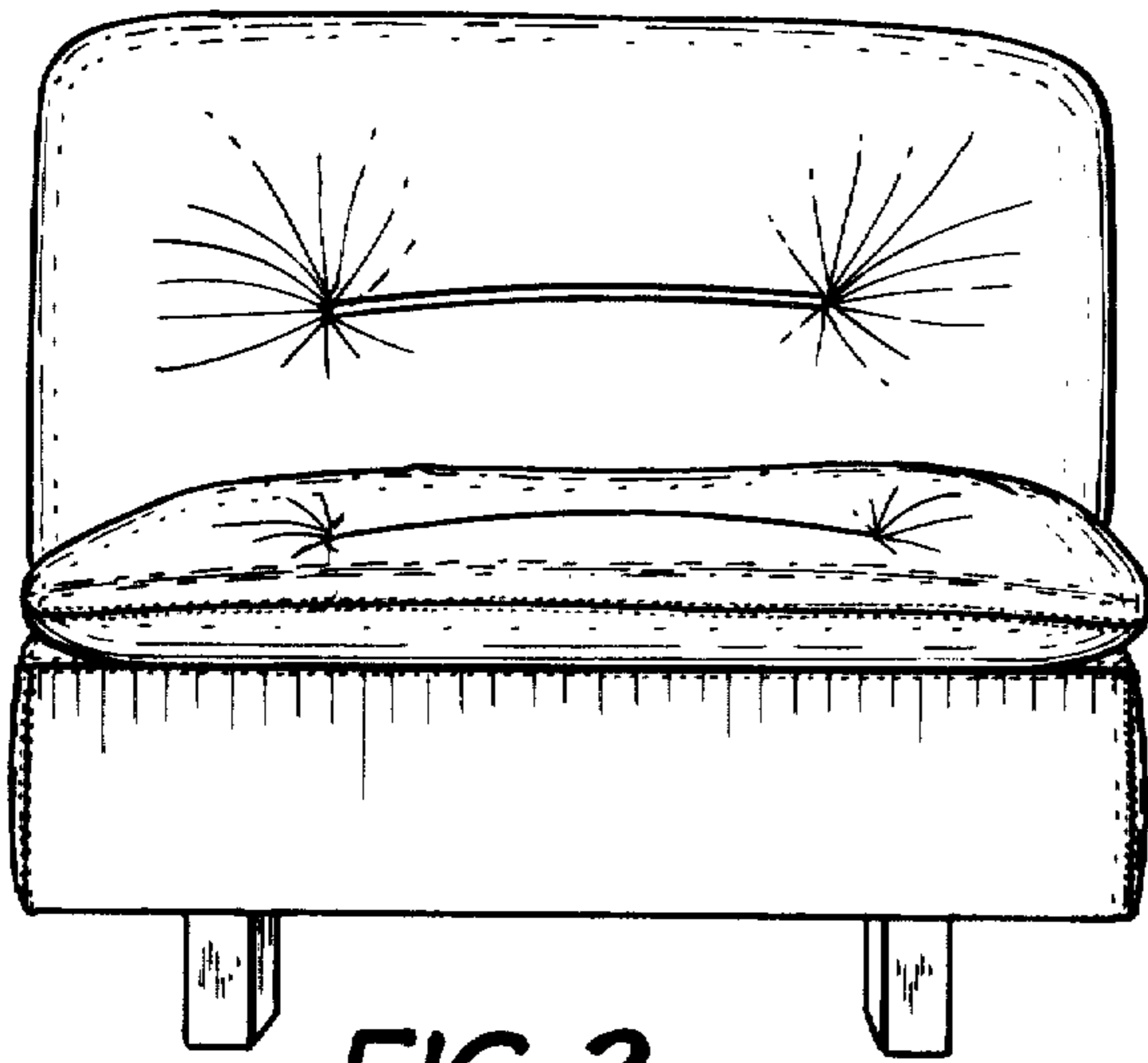

FIG. 2

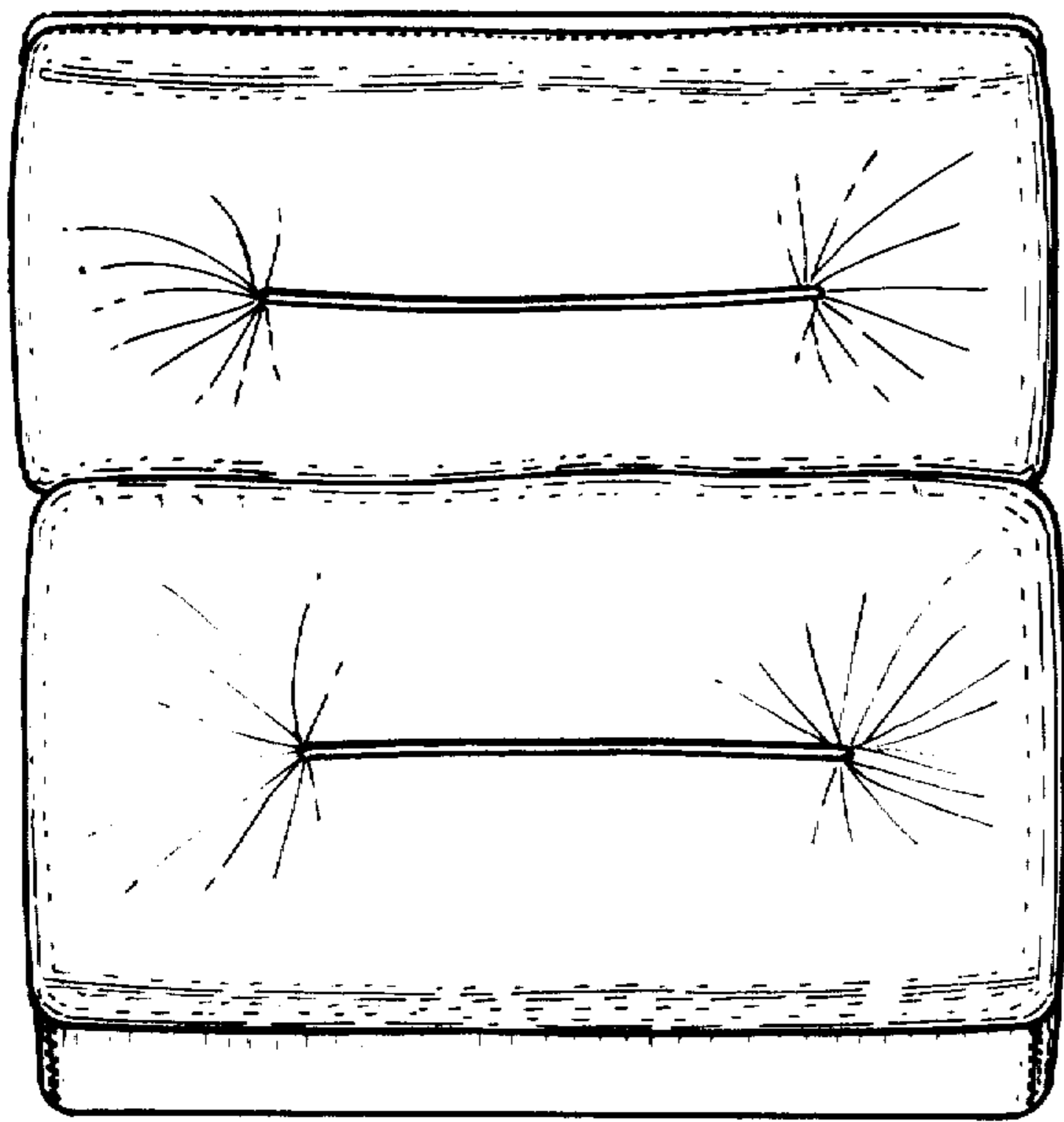

FIG. 4

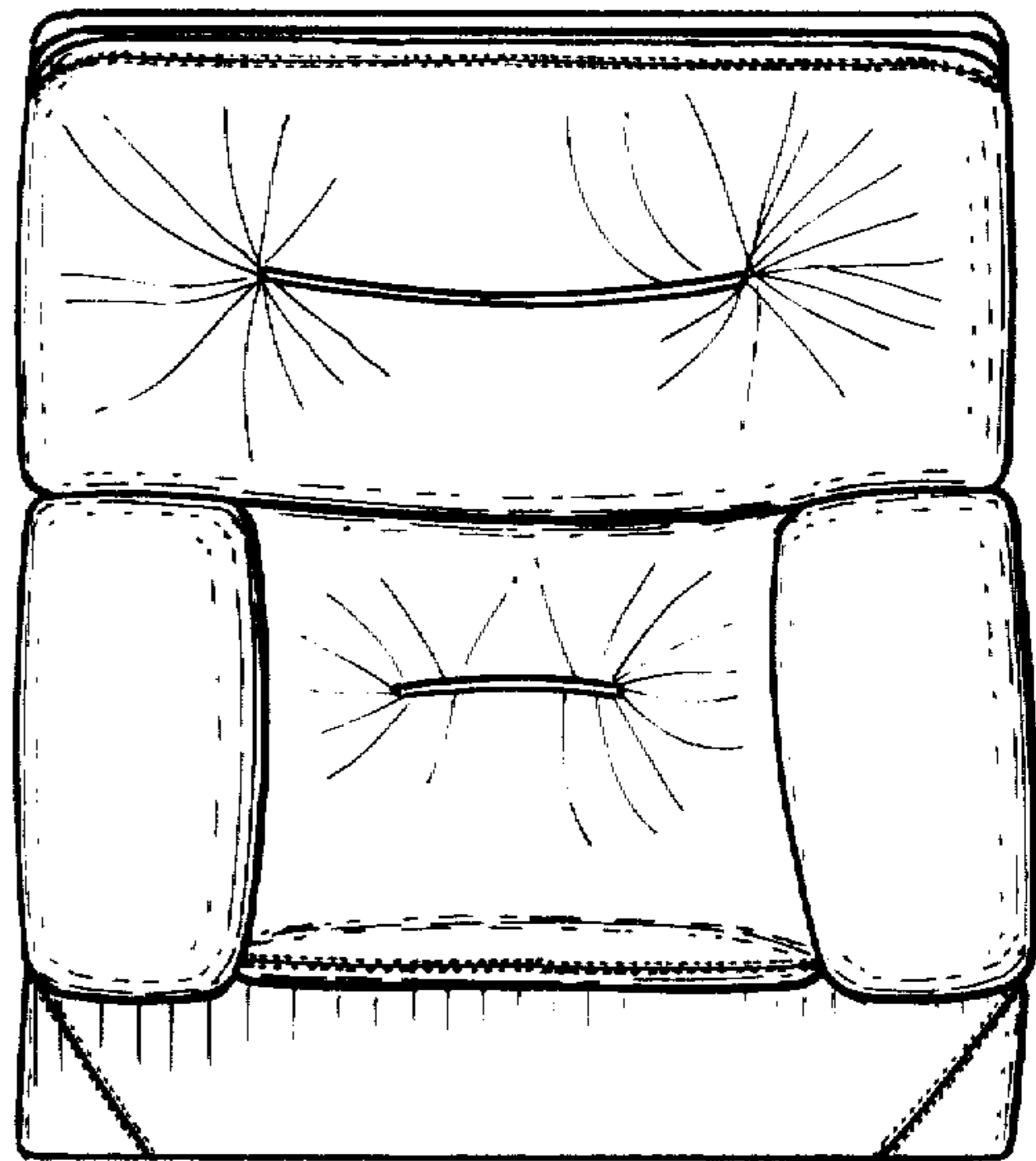

FIG. 5

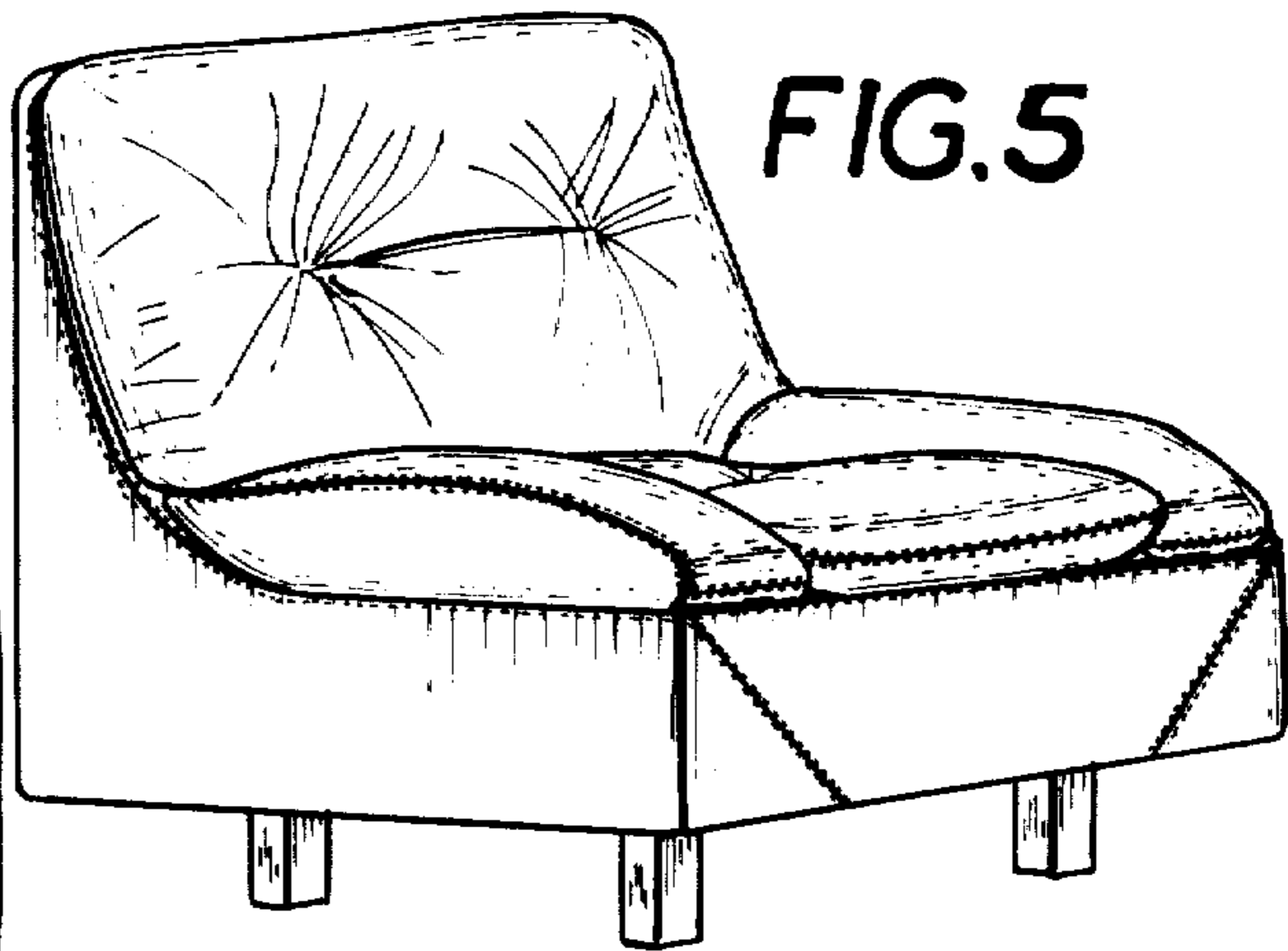

FIG. 6

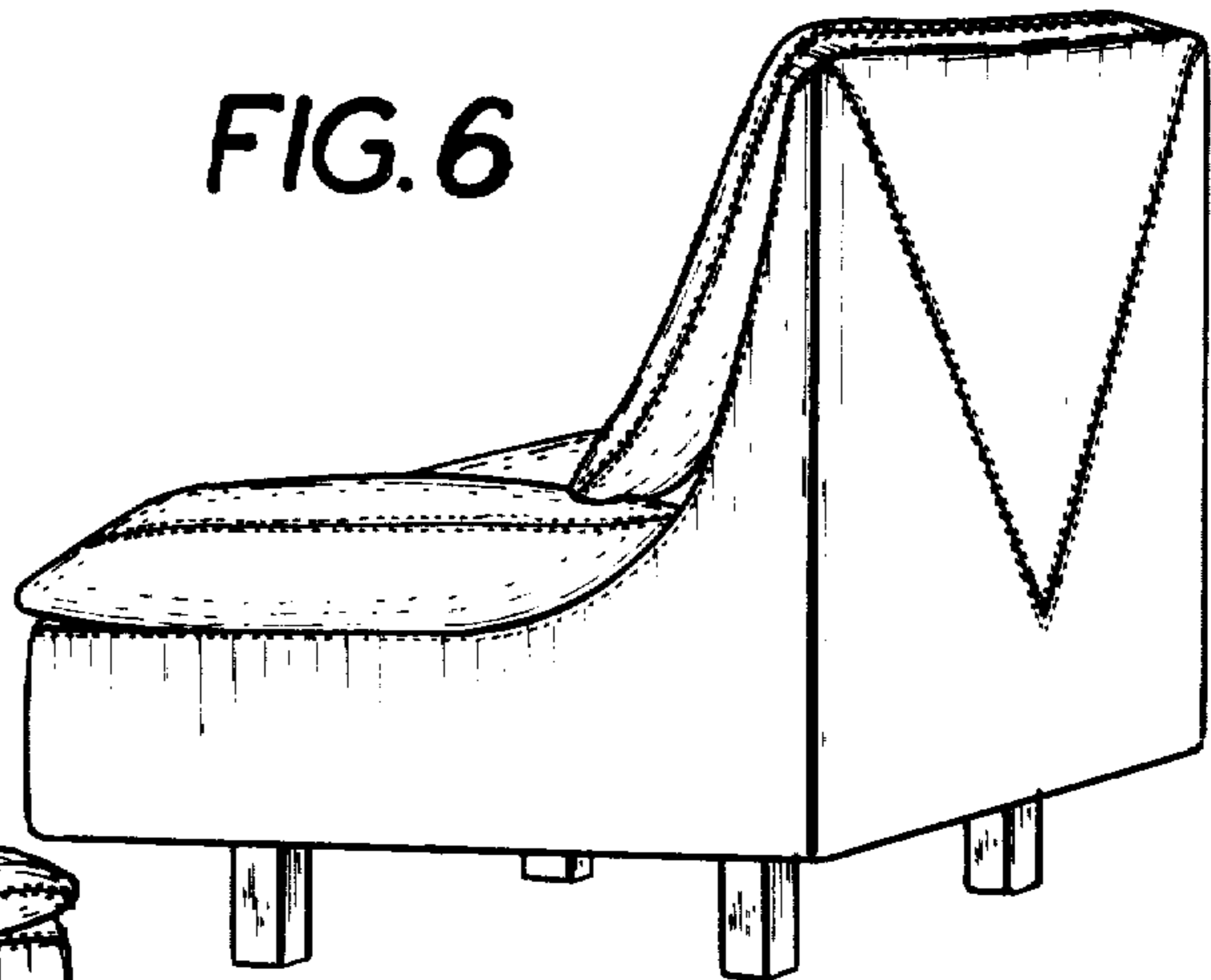
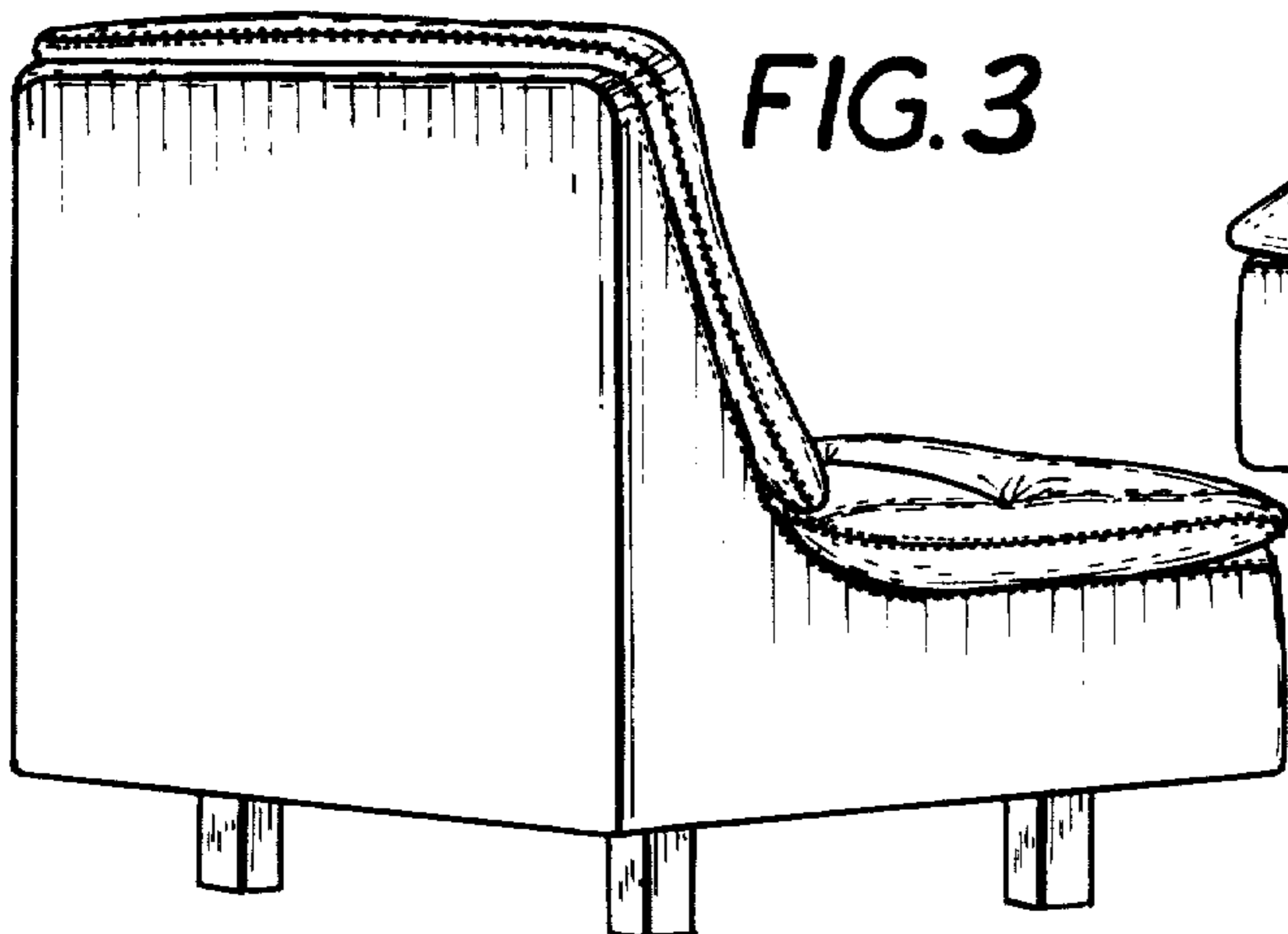

FIG. 3



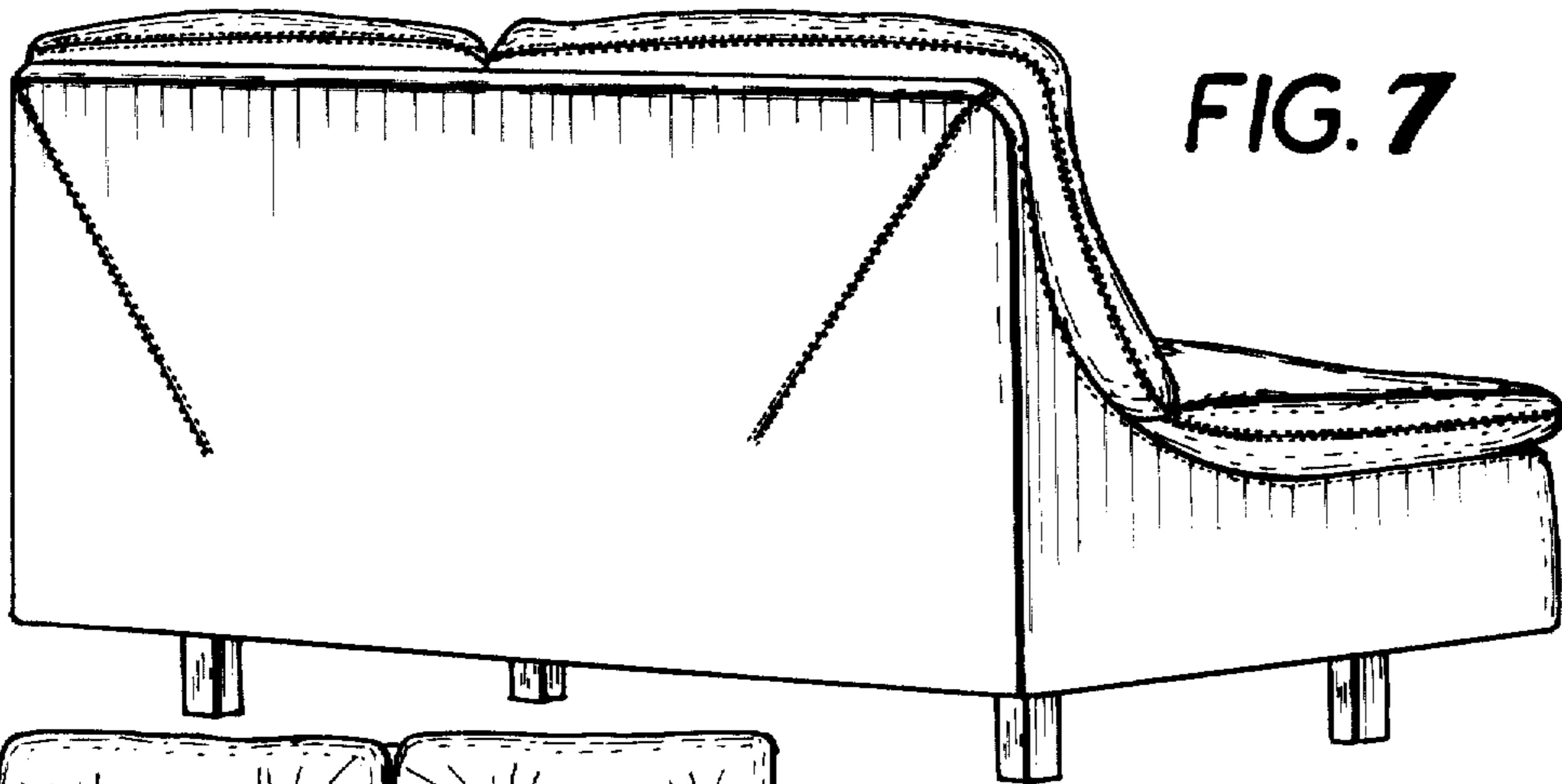

FIG. 7

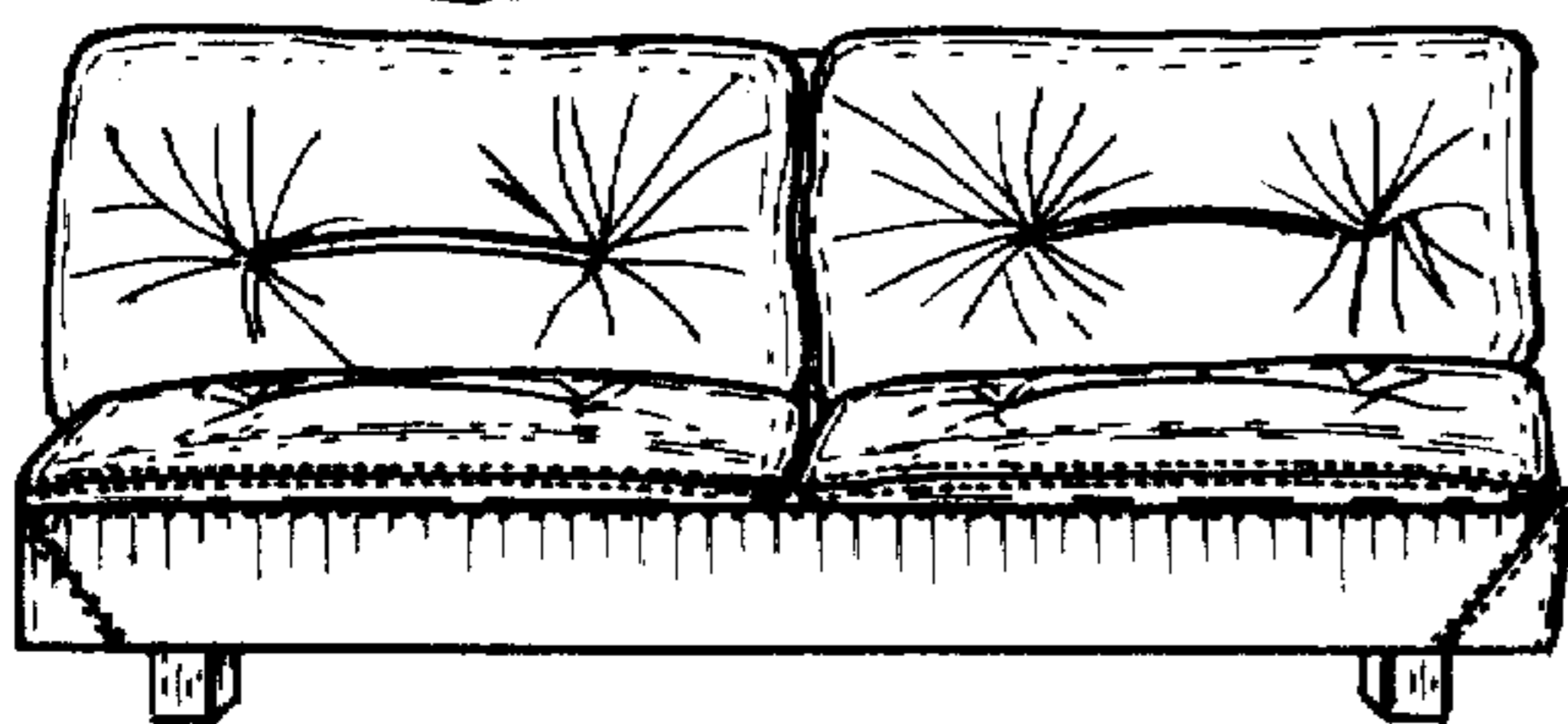

FIG. 8

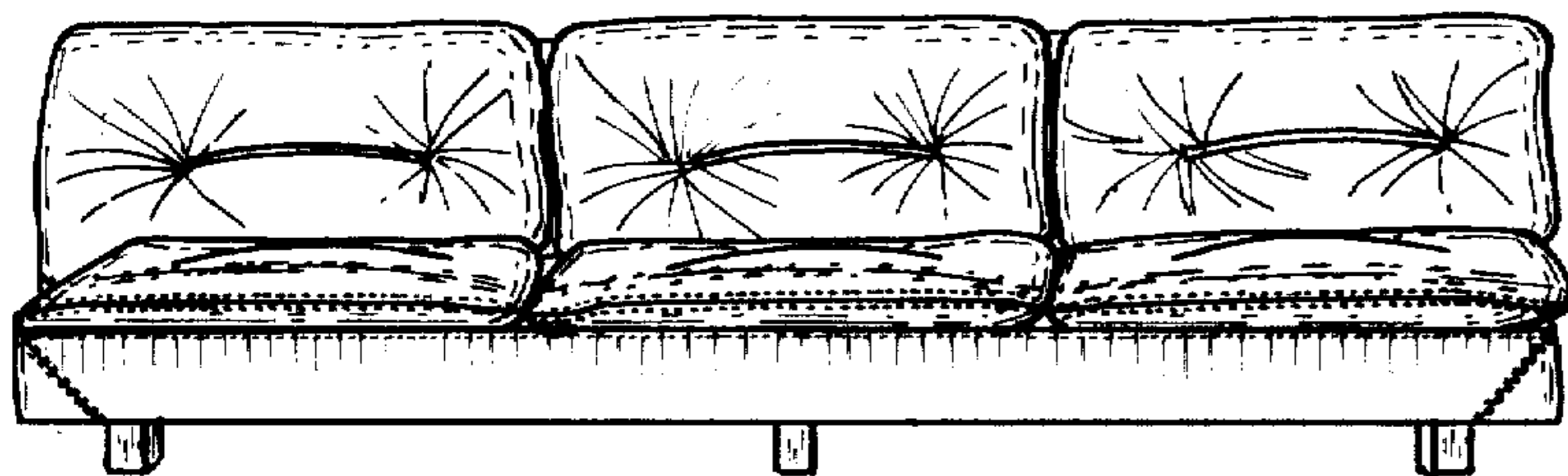

FIG. 9

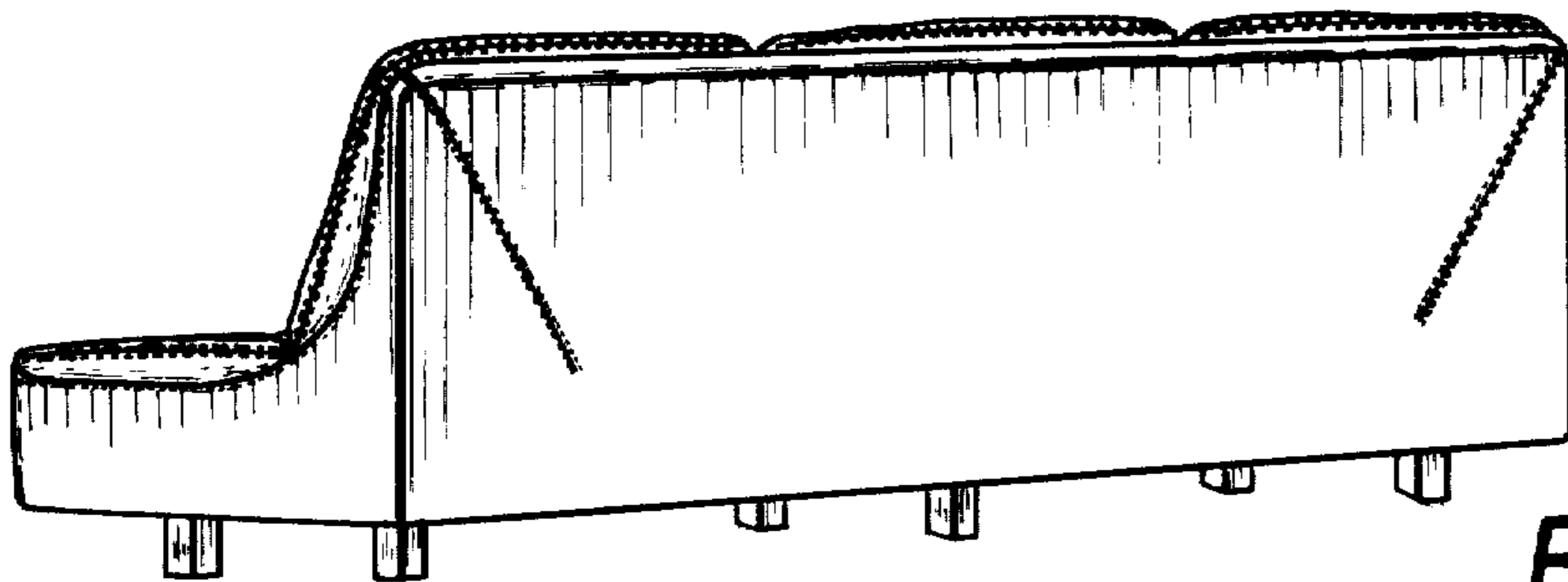

FIG. 10

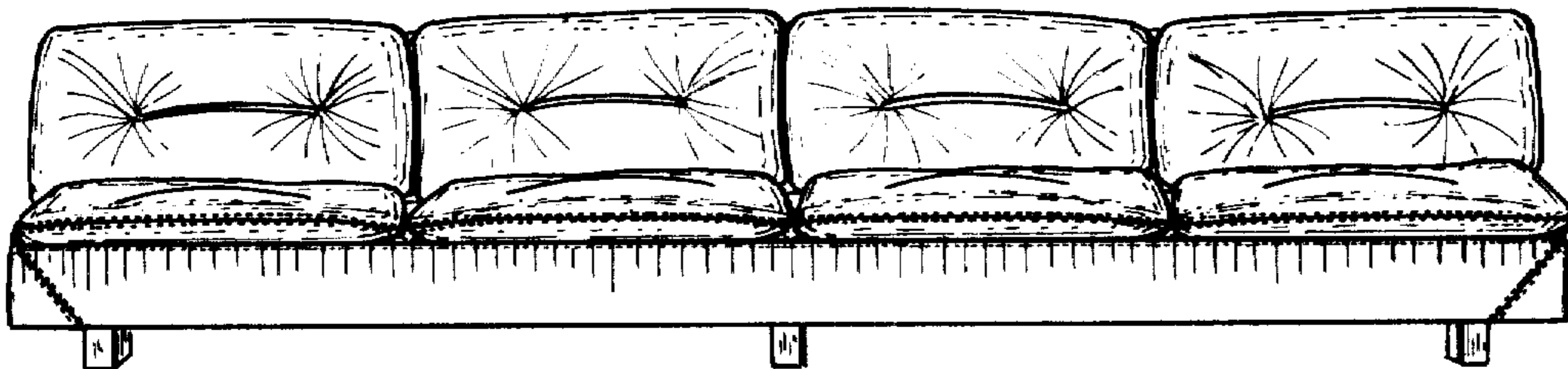

FIG. 11

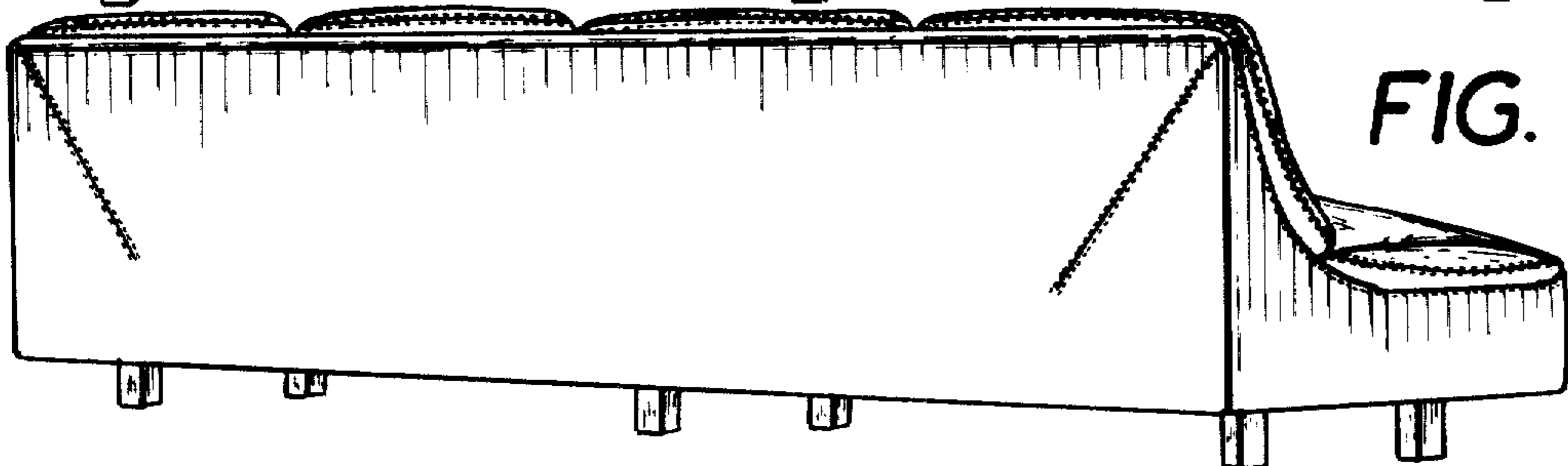

FIG. 12