

[54] **MERCHANDISE DISPLAY MODULE**

[75] Inventor: **Alexander N. Schoenfeld**, Roslyn Heights, N.Y.

[73] Assignee: **Trans-World Display Corporation**, New York, N.Y.

[\*\*] Term: **14 Years**

[21] Appl. No.: **606,685**

[22] Filed: **Aug. 21, 1975**

[51] Int. Cl. .... **D20-02**

[52] U.S. Cl. .... **D6/188**

[58] Field of Search ..... D6/85, 114, 116, 117, D6/118, 132, 137, 157, 181, 185, 186, 188, 189; 211/13, 40, 87, 90; 206/307, 309

[56] **References Cited**

**U.S. PATENT DOCUMENTS**

2,915,193 12/1959 Bromberg ..... D6/114

D. 174,146 3/1955 Tharrington ..... D6/85  
D. 181,901 1/1958 Clarke ..... D6/185  
D. 182,494 4/1958 Berlin ..... D6/185  
D. 224,003 6/1972 Dumm ..... D6/85

**FOREIGN PATENT DOCUMENTS**

1,421,916 1965 France ..... 211/40

*Primary Examiner*—Wallace R. Burke

*Assistant Examiner*—B. J. Bullock

*Attorney, Agent, or Firm*—Alan H. Levine

[57] **CLAIM**

The ornamental design for a merchandise display module, substantially as shown.

**DESCRIPTION**

FIG. 1 is a top, front, and right side perspective view of a merchandise display module showing my new design; and

FIG. 2 is a bottom, rear, and left side perspective view.

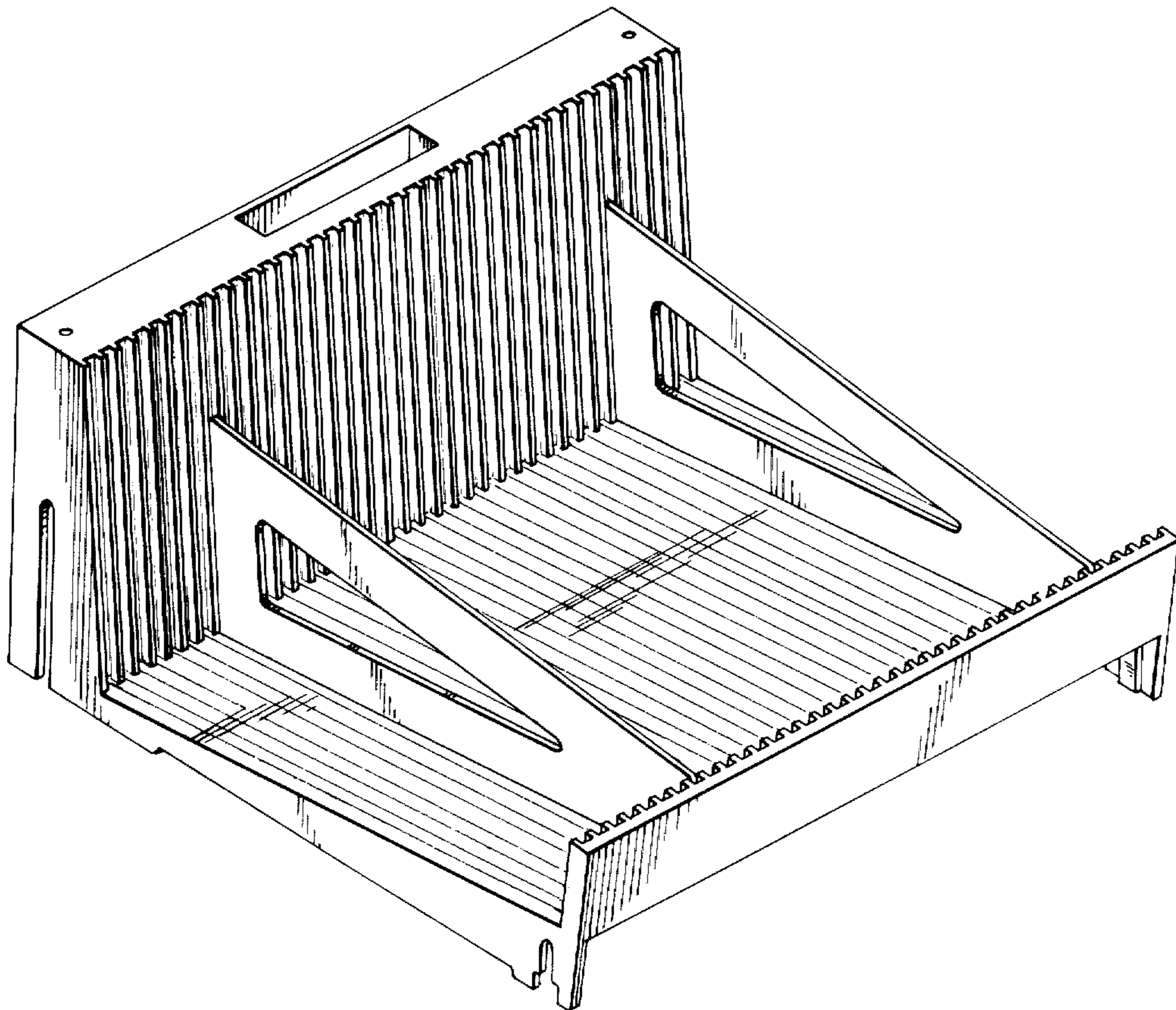

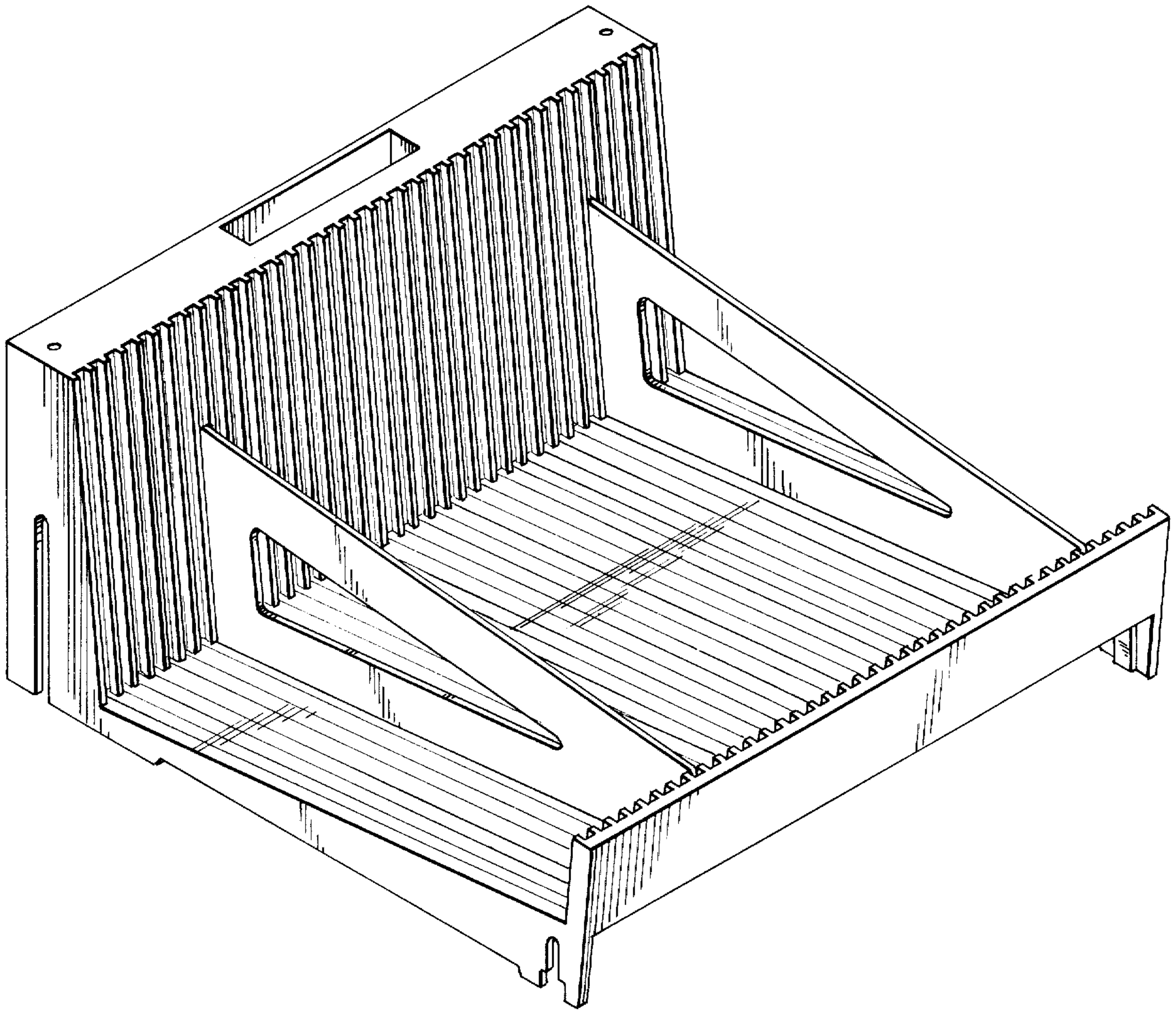

*FIG. 1*

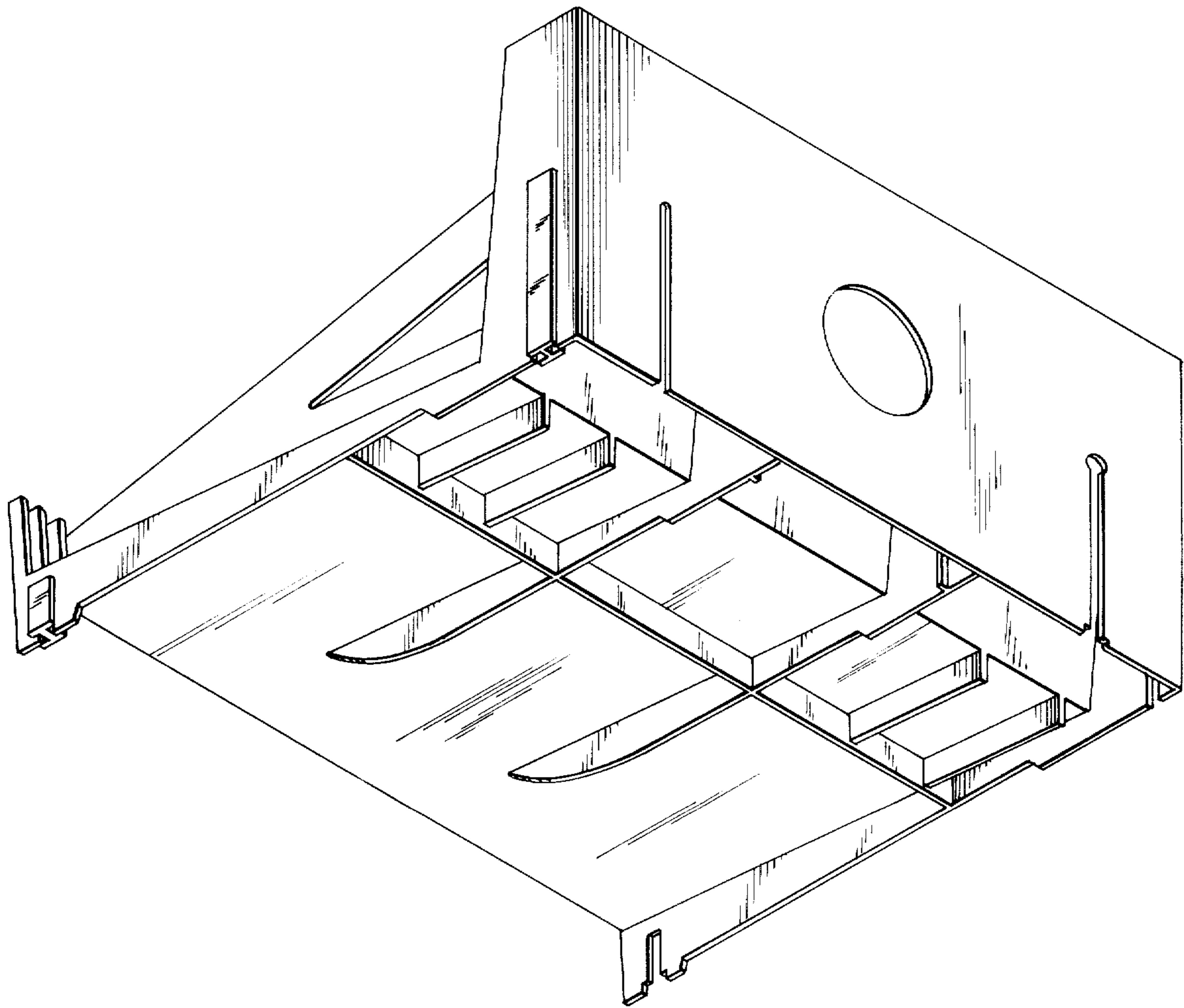

**FIG. 2**