

[54] **SNOWMOBILE TRACK**

[75] **Inventor: Jean-Rock Belanger,**
Drummondville, Canada

[73] **Assignee: Bombardier Limited**

[**] **Term: 14 Years**

[21] **Appl. No.: 592,272**

[22] **Filed: July 1, 1975**

[30] **Foreign Application Priority Data**

Mar. 21, 1975 Canada 210375

[51] **Int. Cl. D12-14**

[52] **U.S. Cl. D12/7**

[58] **Field of Search D12/7; D40/5 B;**
305/35 EB, 35 R, 38; 180/5 R; 198/193, 198

[56] **References Cited**

U.S. PATENT DOCUMENTS

3,582,154 6/1971 Russ, Sr. D12/7 UX
3,637,267 1/1972 Bombardier et al. 305/35 EB

Primary Examiner—Wallace R. Burke
Assistant Examiner—James M. Gandy
Attorney, Agent, or Firm—Eric L. Medcalf

[57] **CLAIM**

The ornamental design for a snowmobile track, as shown and described.

DESCRIPTION

FIG. 1 is a perspective view of a snowmobile track showing my new design; it being understood that the tread design continues uniformly through the belt indicated in light full lines; and
FIG. 2 is an enlarged fragmentary plan view of a portion of the tread design shown in FIG. 1.

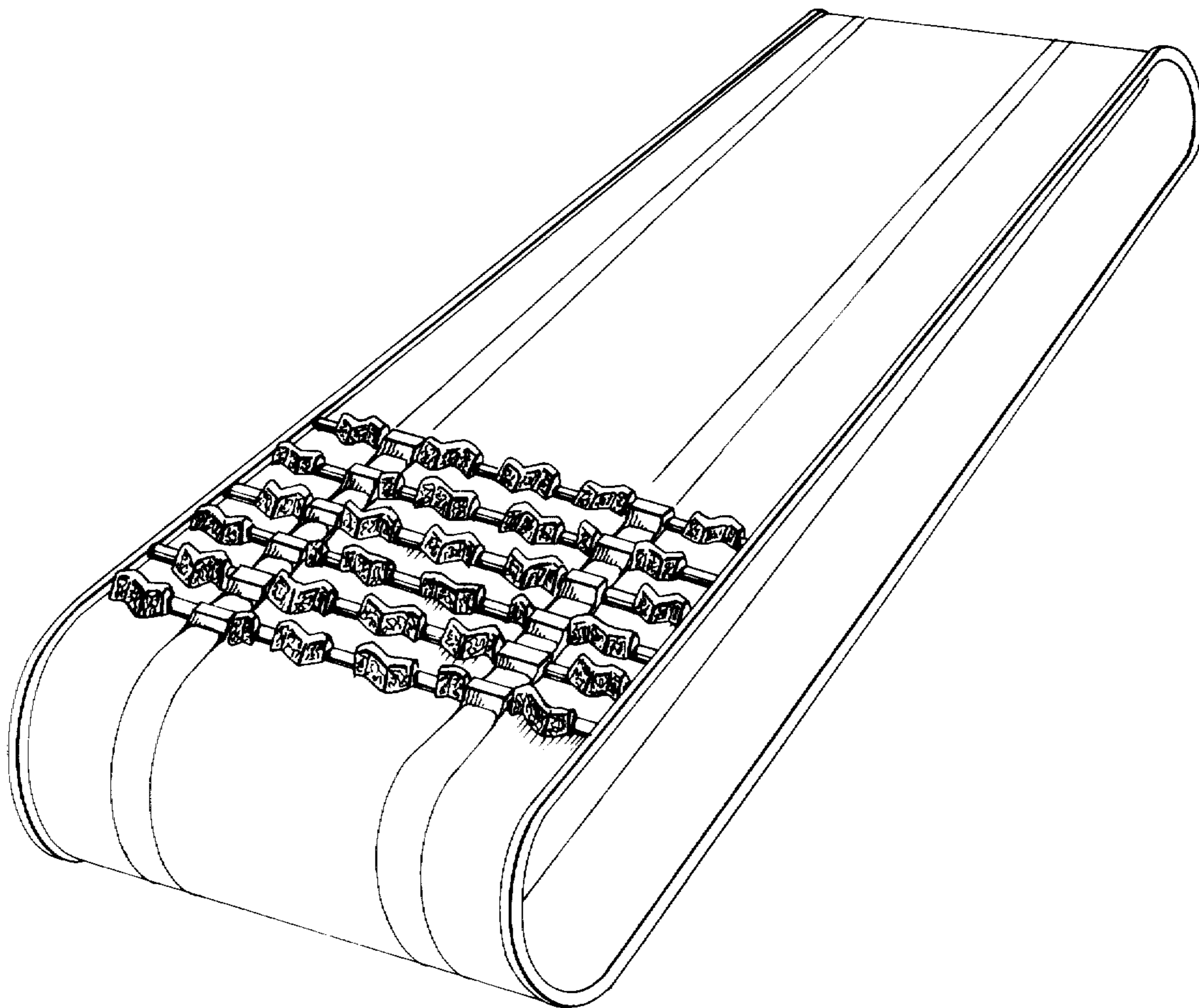

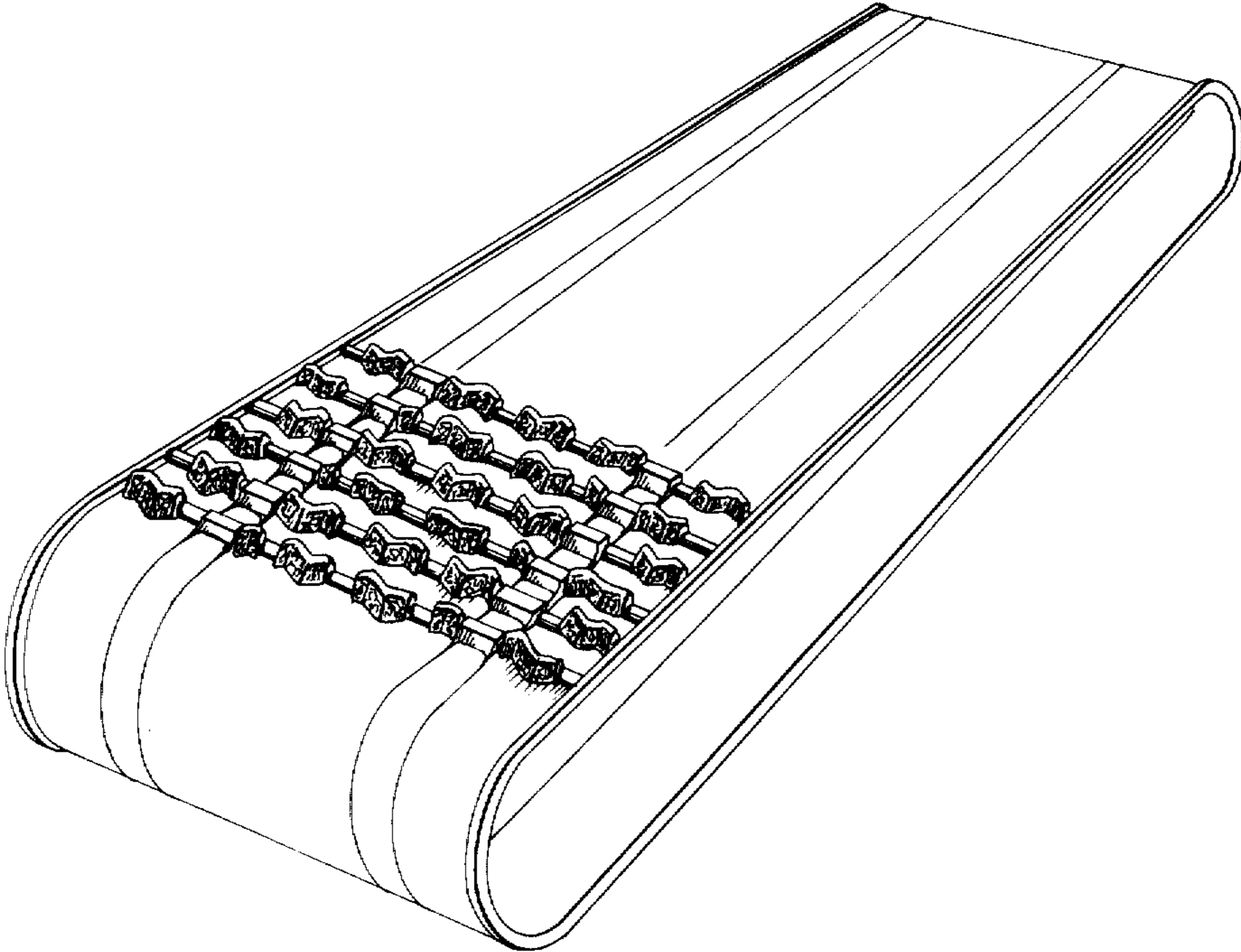

FIG. 1

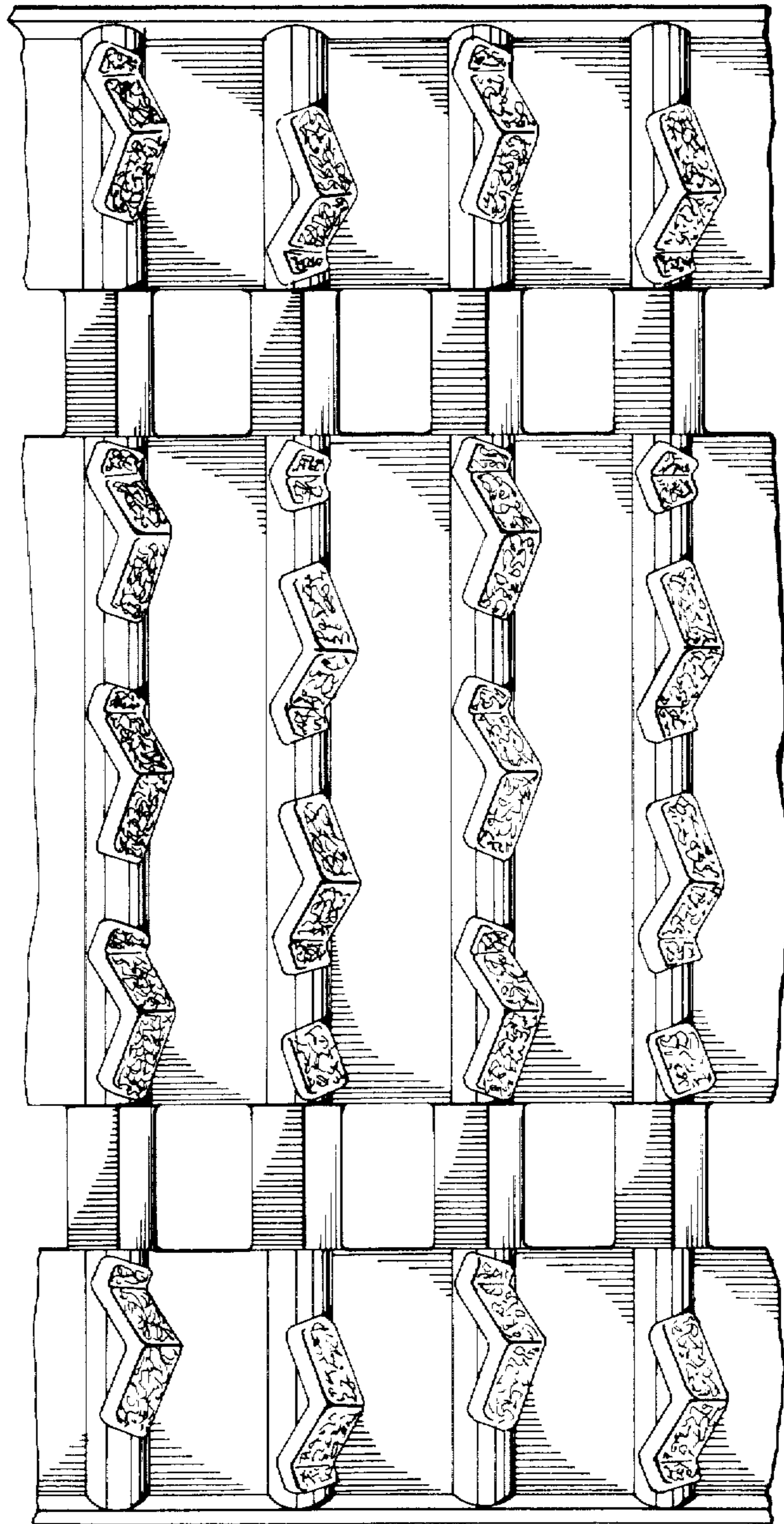

FIG. 2