

[54] POWER MODULE FOR ELECTRONIC ENGINE IGNITION SYSTEMS

[76] Inventor: Craig S. Beshore, 753 Puma Canyon Lane, Glendora, Calif. 91740

[\*\*] Term: 14 Years

[21] Appl. No.: 611,982

[22] Filed: Sept. 10, 1975

[51] Int. Cl. .... D13-03

[52] U.S. Cl. .... D26/1 R

[58] Field of Search ..... D26/1 R, 5 A; 123/148 E, 148 OC

[56] References Cited

OTHER PUBLICATIONS

Electronic Ignition, p. 6, 1975, From 123-148e.  
Autocar, March 15, 1963, p. 463, Ignition Unit.  
J. C. Whitney Catalog No. 328A, 1974, p. 76, lower right.

Electronics World, Oct., 1962, p. 100, Transistor Ignition.

Electronics, Sept., 1970, p. 68. Ignition System.

Primary Examiner—Susie J. Mercer

Assistant Examiner—Christine M. Nucker

Attorney, Agent, or Firm—Boniard I. Brown

[57] CLAIM

The ornamental design for a power module for electronic engine ignition systems, as shown and described.

DESCRIPTION

FIG. 1 is a perspective view of a power module, showing my new design;

FIG. 2 is a front view thereof;

FIG. 3 is a side elevational view thereof;

FIG. 4 is a bottom view thereof; and

FIG. 5 is a rear view thereof.

The side not shown is a mirror image of the side shown in FIG. 3.

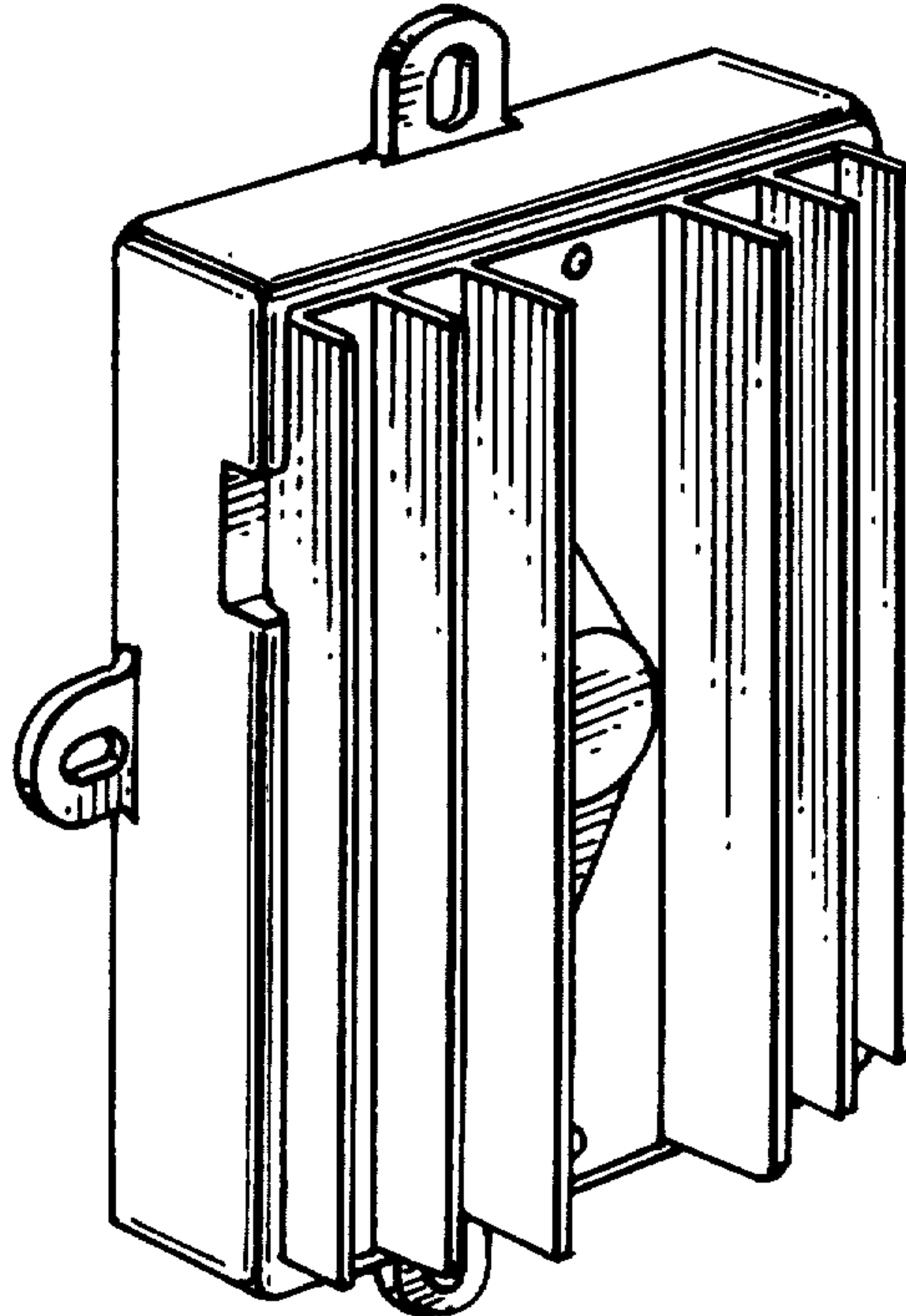

*Fig. 1.*

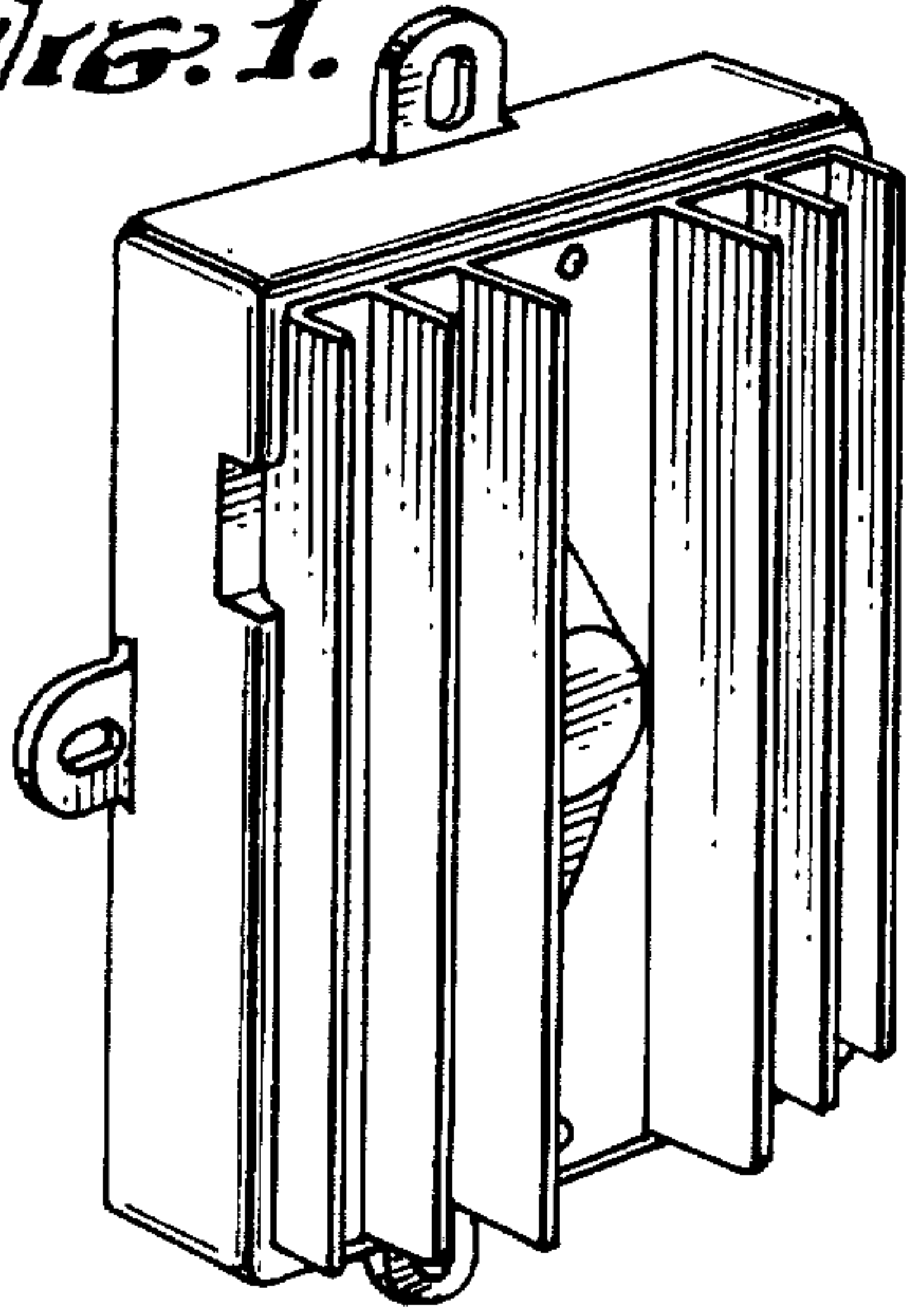

*Fig. 5.*

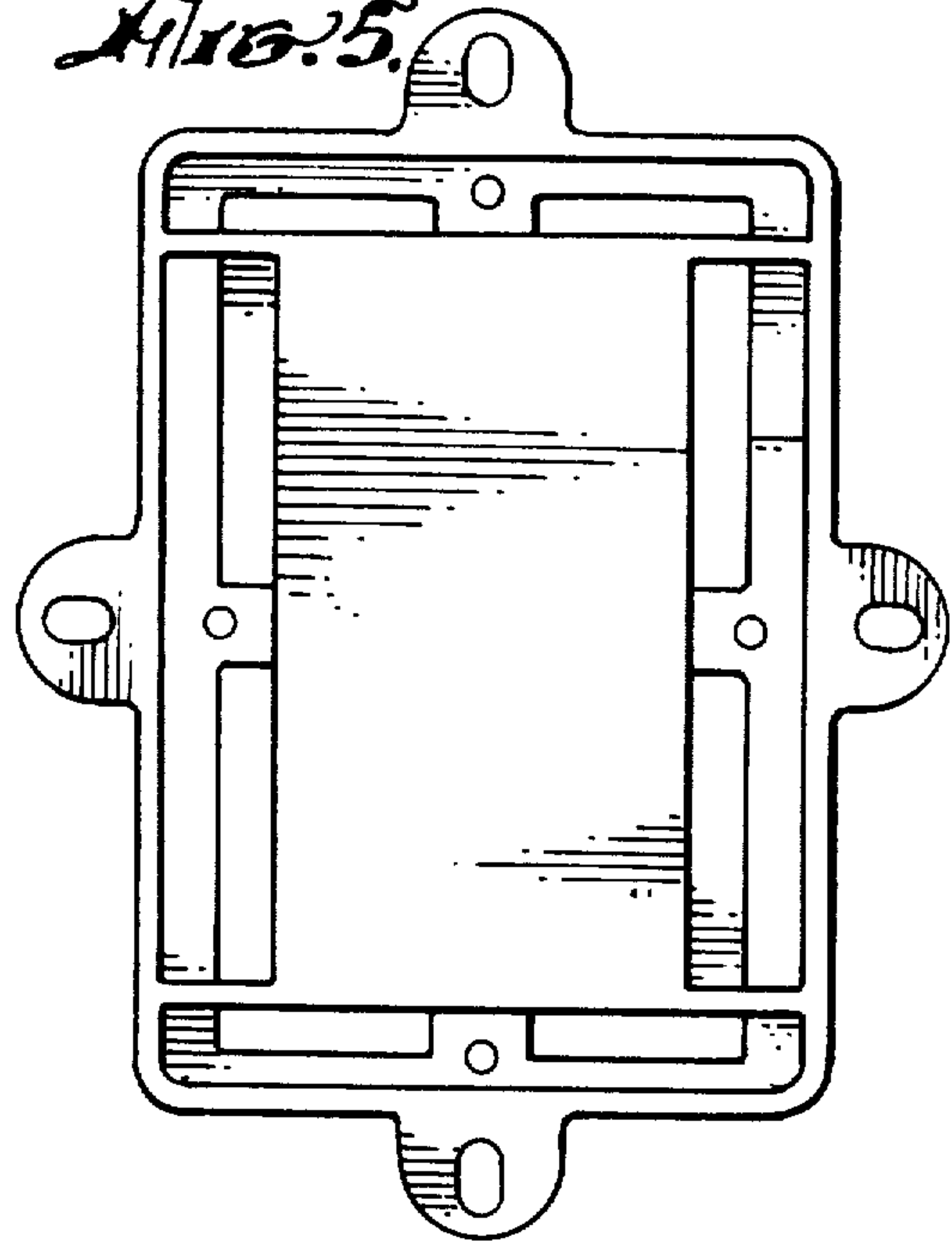

*Fig. 2.*

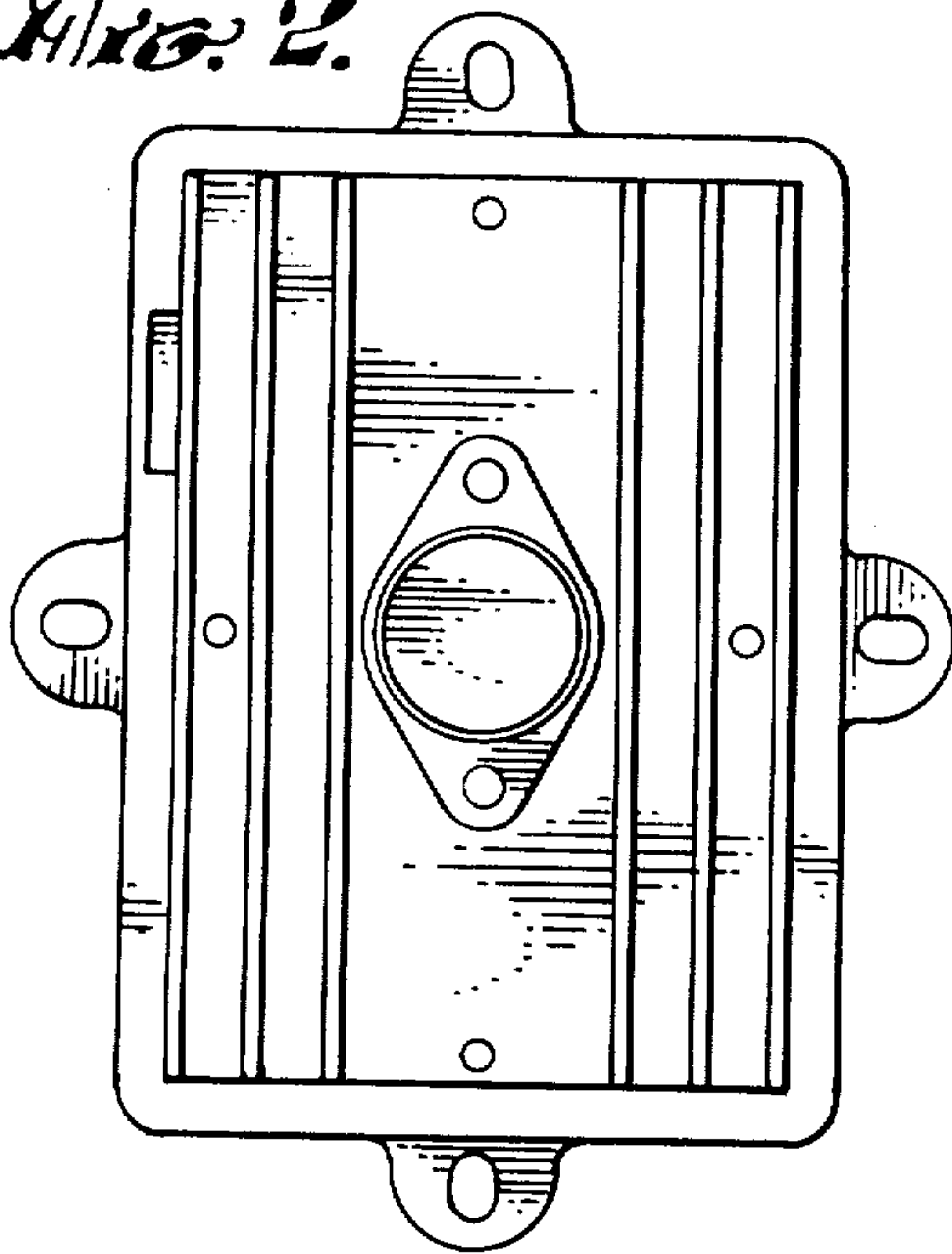

*Fig. 3.*

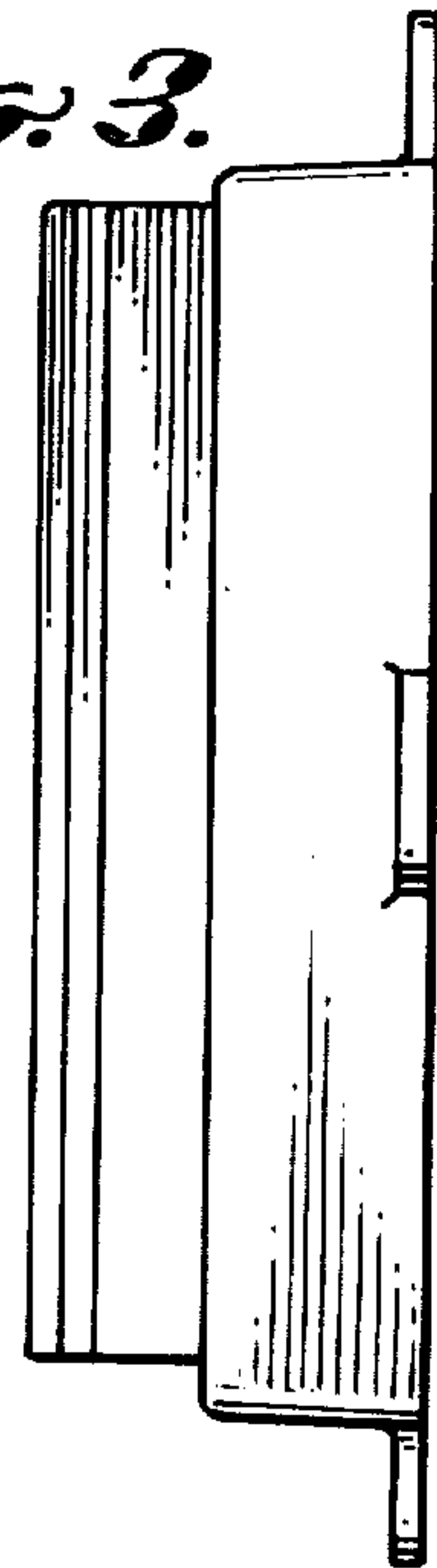

*Fig. 4.*

