

[54] MULTI-PURPOSE SELF-PROPELLED VEHICLE

[76] Inventor: Paul E. Tolar, 401 N. West St., Wichita, Kans. 67203

[**] Term: 14 Years

[21] Appl. No.: 617,275

[22] Filed: Sept. 29, 1975

[51] Int. Cl. D12-14

[52] U.S. Cl. D12/1

[58] Field of Search D12/1, 85, 88, 114, D12/128, 131; D40/5 R, 1 D; 180/14 R, 25 R, 27, 1 R

[56] References Cited

U.S. PATENT DOCUMENTS

3,485,314 12/1969 Herr 180/14 R

3,840,085 10/1974 Smith D12/114
D. 210,758 4/1968 Binder D12/112

Primary Examiner—Wallace R. Burke
Assistant Examiner—James M. Gandy
Attorney, Agent, or Firm—John H. Widdowson

[57] CLAIM

The ornamental design for a multi-purpose self-propelled vehicle, substantially as shown.

DESCRIPTION

FIG. 1 is a side elevation view of a multi-purpose self-propelled vehicle showing my new design; FIG. 2 is a top plan view thereof; FIG. 3 is a side elevation view thereof opposite to that shown in FIG. 1; FIG. 4 is a front elevation view thereof; and FIG. 5 is a rear elevation view thereof.

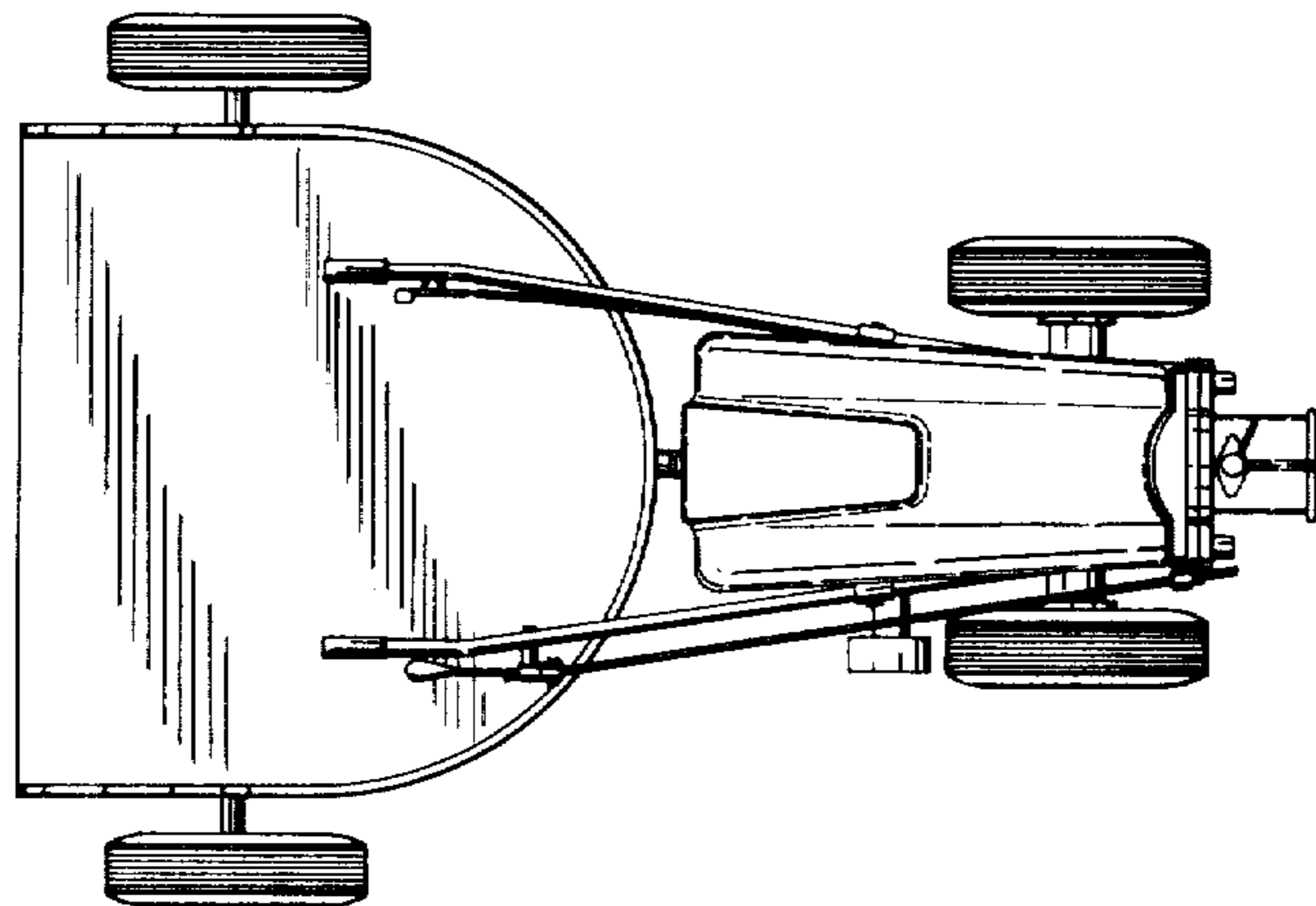
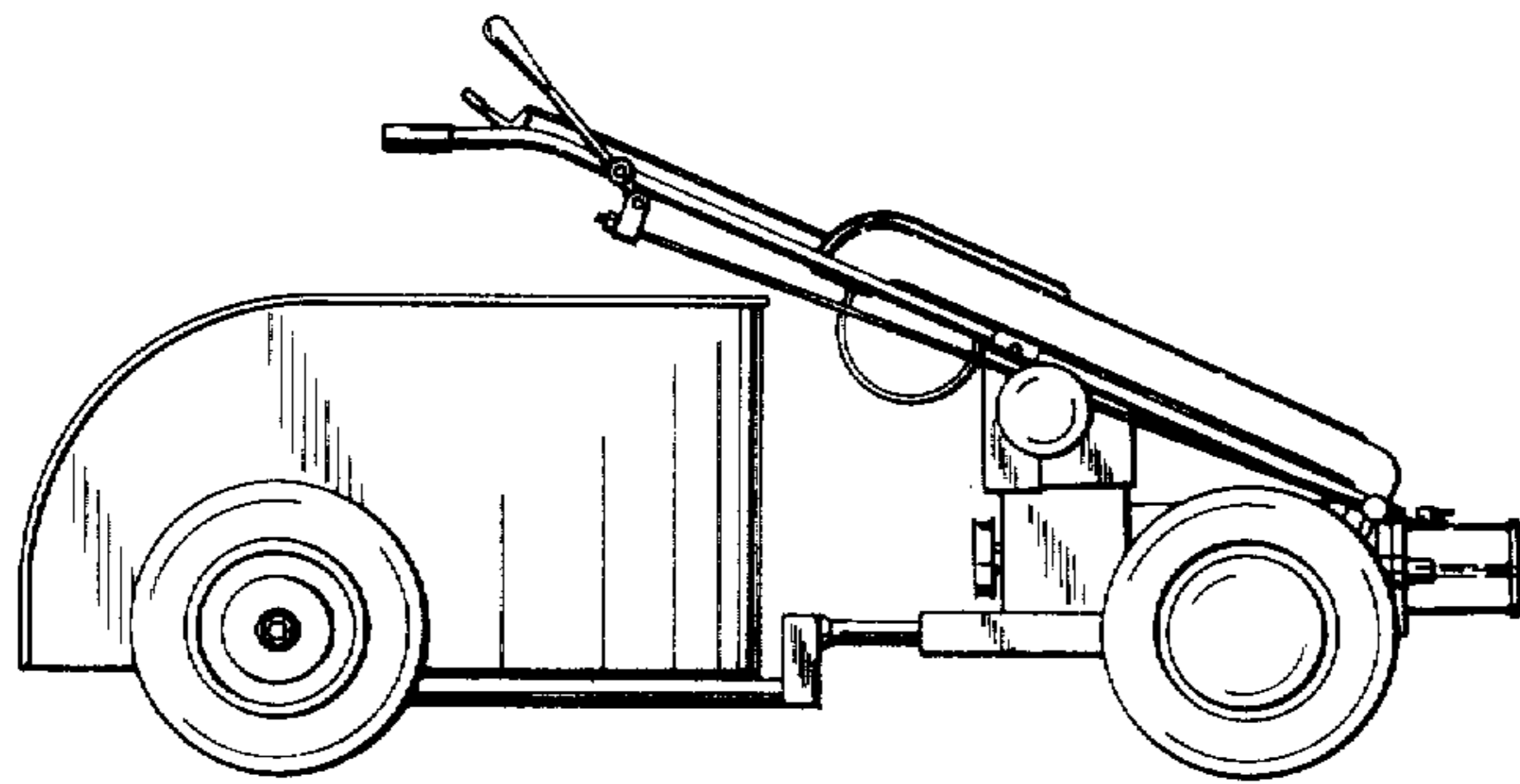

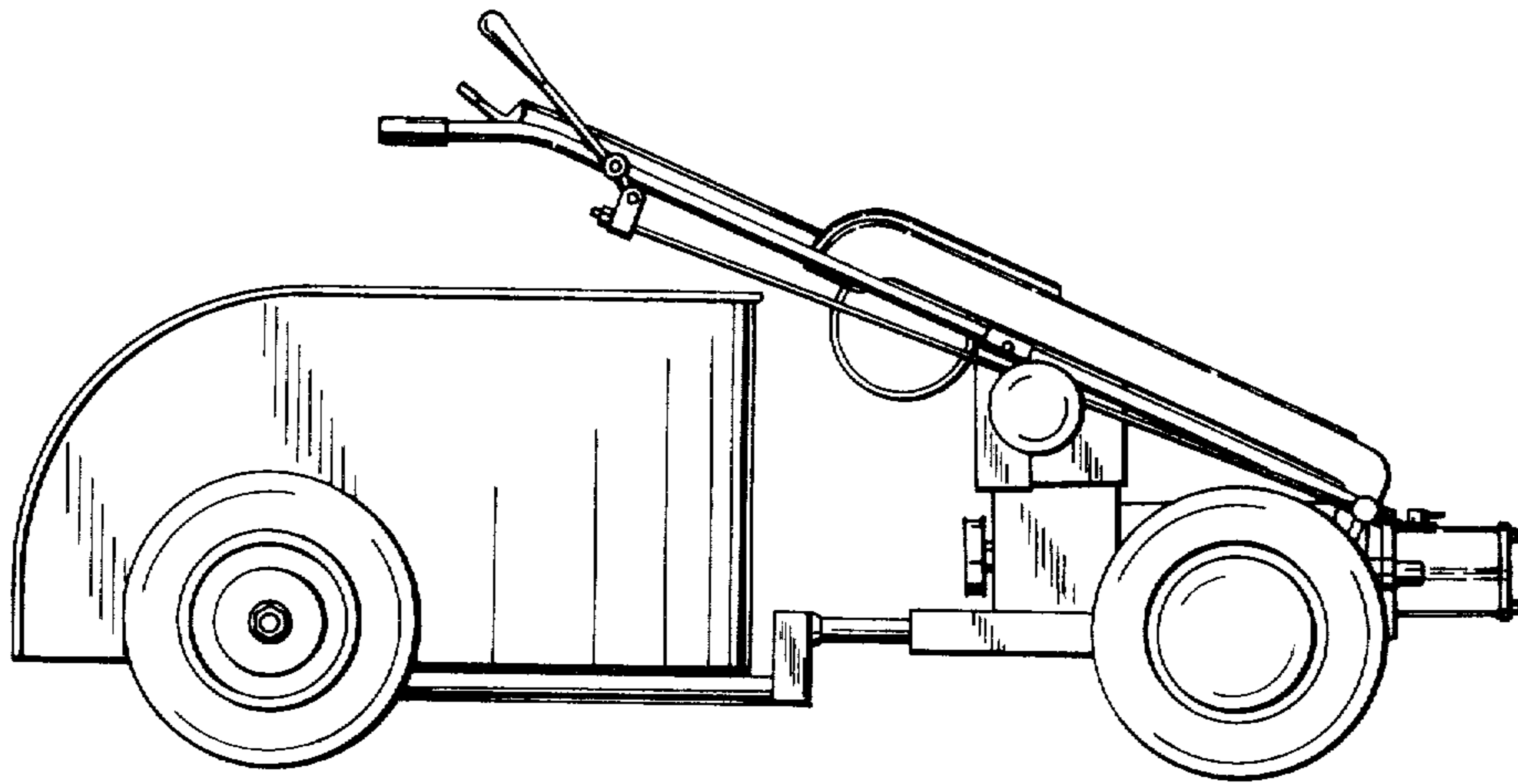

FIG. 1

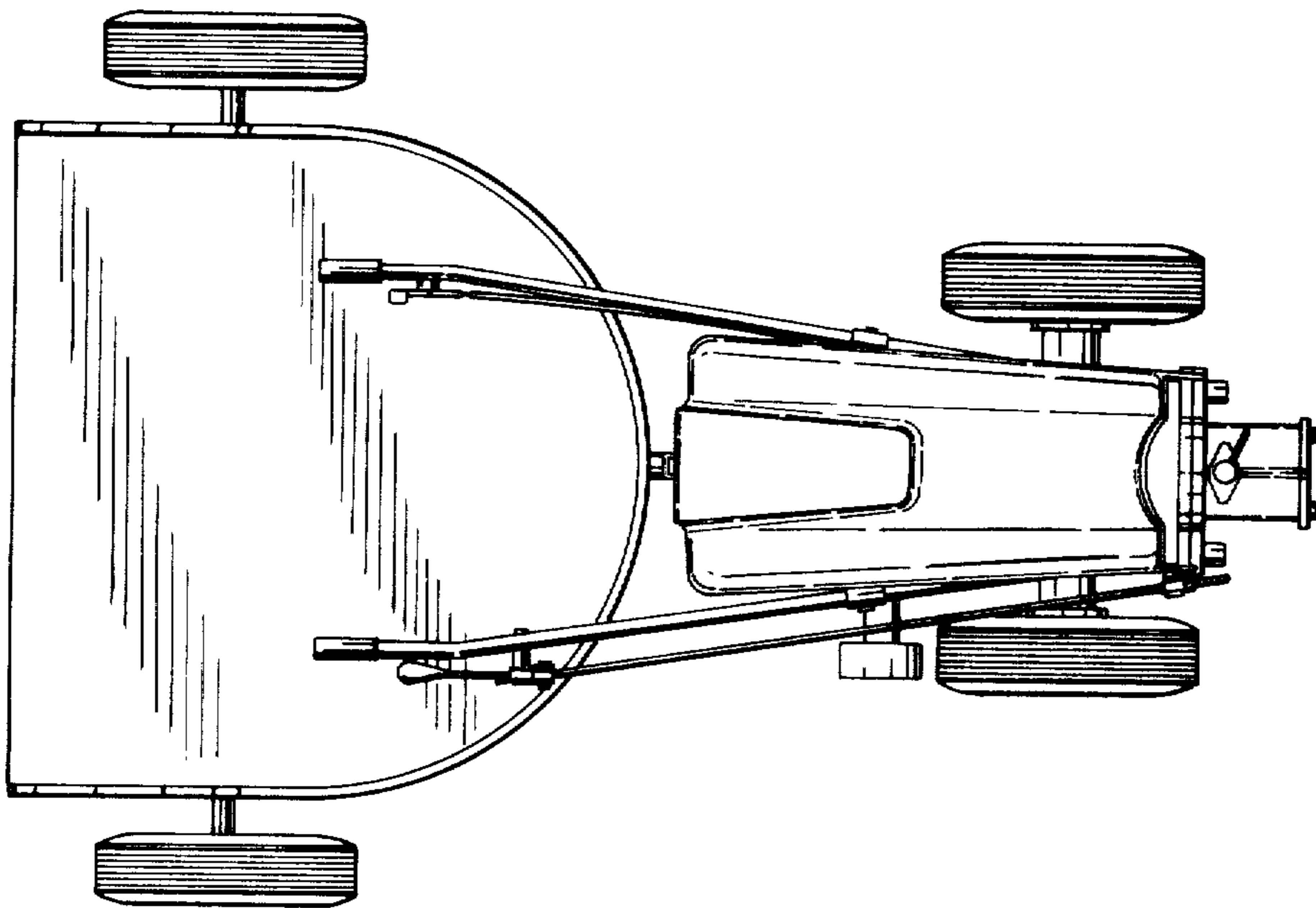

FIG. 2

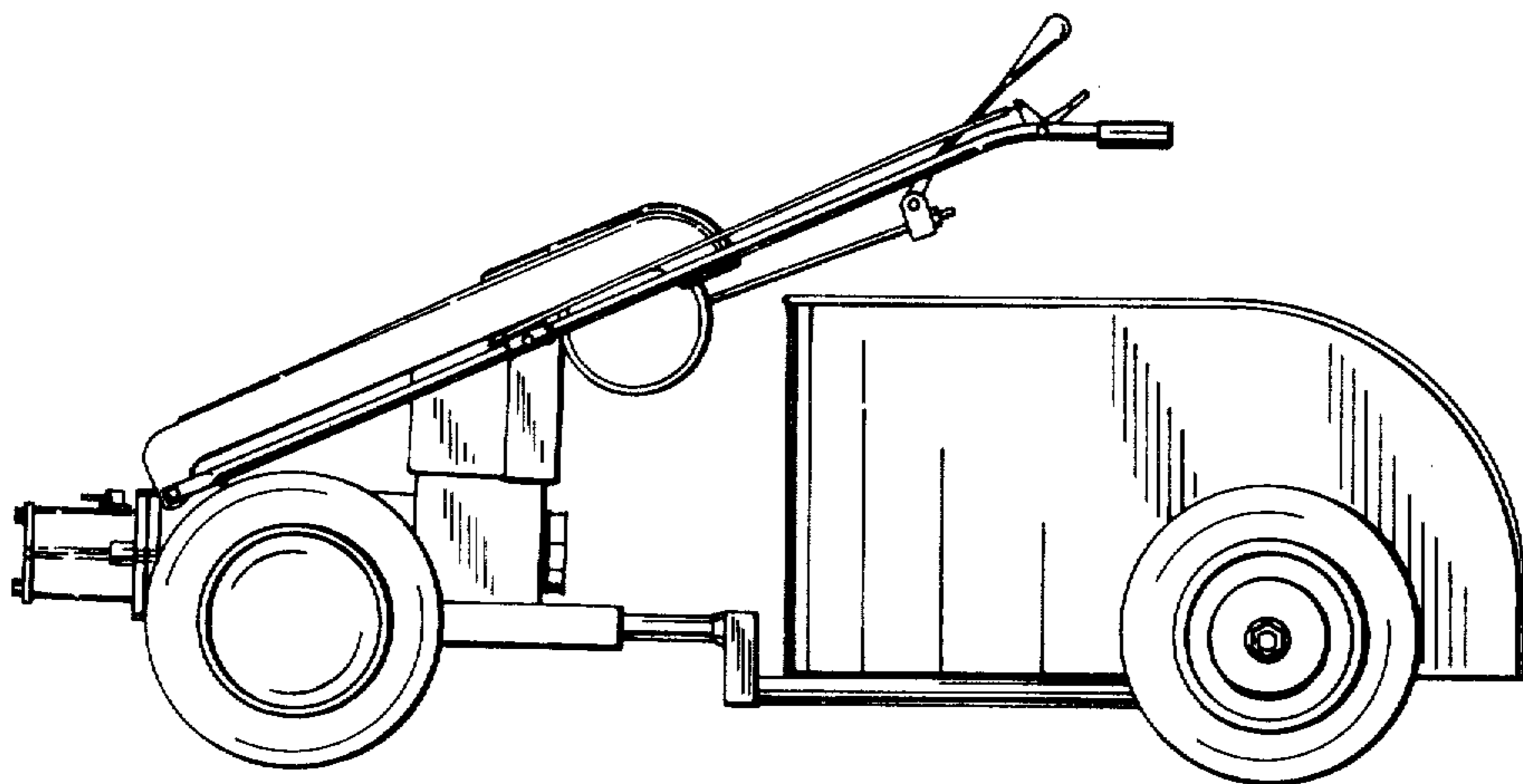

FIG. 3

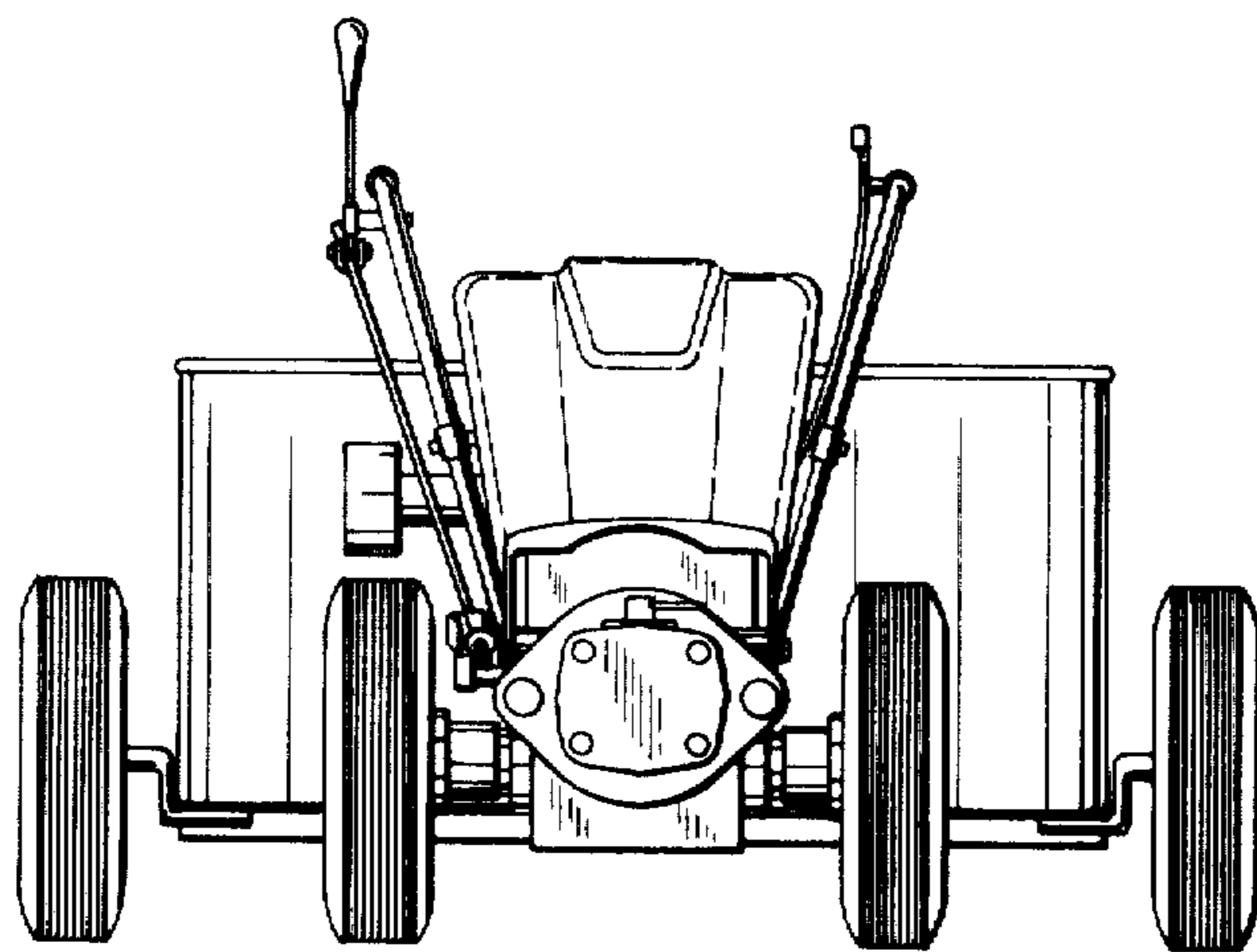

FIG. 4

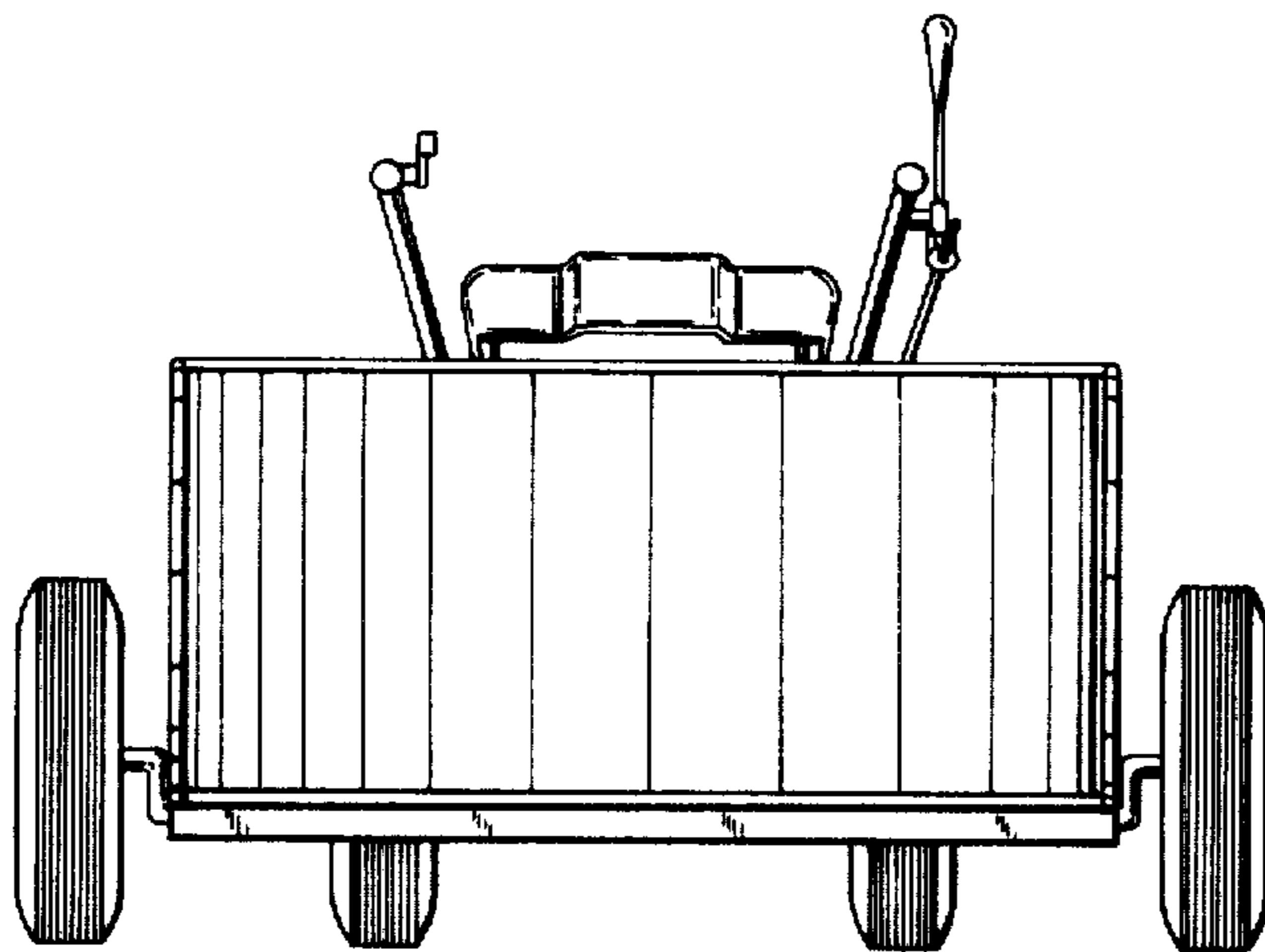

FIG. 5