

Reynolds

[54] HANDRAIL FOR VEHICLES

[76] Inventor: Robert L. Reynolds, 7931 Oranewood, Stanton, Calif. 90680

[**] Term: 14 Years

[21] Appl. No.: 606,426

[22] Filed: Aug. 21, 1975

[51] Int. Cl. D25-02; D12-99

[52] U.S. Cl. D25/38

[58] Field of Search D25/38, 43, 45, 89, D25/71; D12/106, 155; 296/23 R; 280/163, 164 R, 166; 256/1, 21, 22, 32, 37, 40, 59, 65

[56] References Cited

U.S. PATENT DOCUMENTS

202,405	4/1878	Brines	256/22
2,840,349	6/1958	Raymond	256/21
2,870,996	1/1959	Helt	256/65
3,704,005	11/1972	Kusel	256/22

Primary Examiner—Wallace R. Burke
Assistant Examiner—James M. Gandy
Attorney, Agent, or Firm—Harvey C. Nienow

[57] CLAIM

The ornamental design for a handrail for vehicles, as shown.

DESCRIPTION

FIG. 1 is an isometric view of a handrail for vehicles showing my new design;
FIG. 2 is a side elevational view thereof to an enlarged scale;
FIG. 3 is a front elevational view thereof to an enlarged scale;
FIG. 4 is a rear elevational view thereof to an enlarged scale;
FIG. 5 is a bottom plan view thereof to an enlarged scale; and
FIG. 6 is a top plan view thereof to an enlarged scale.

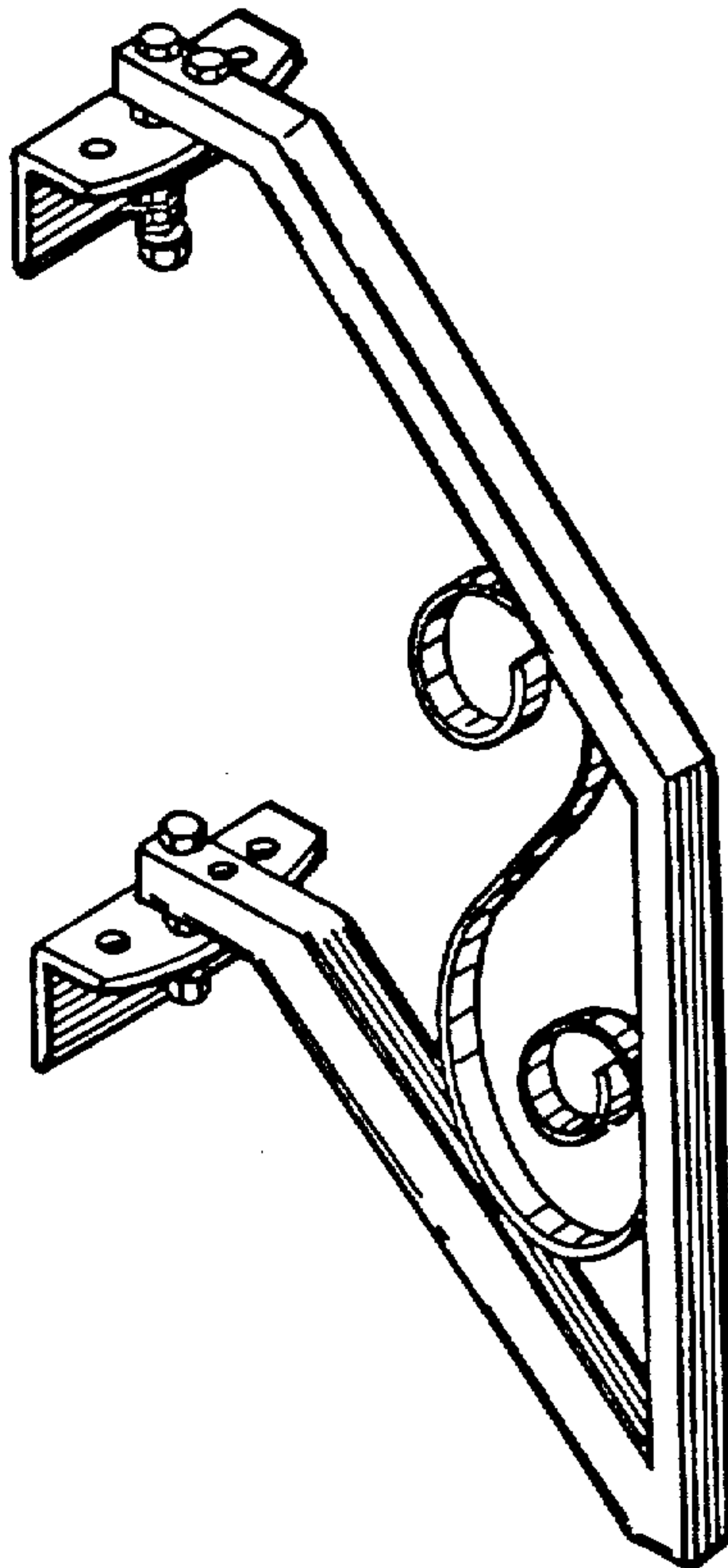

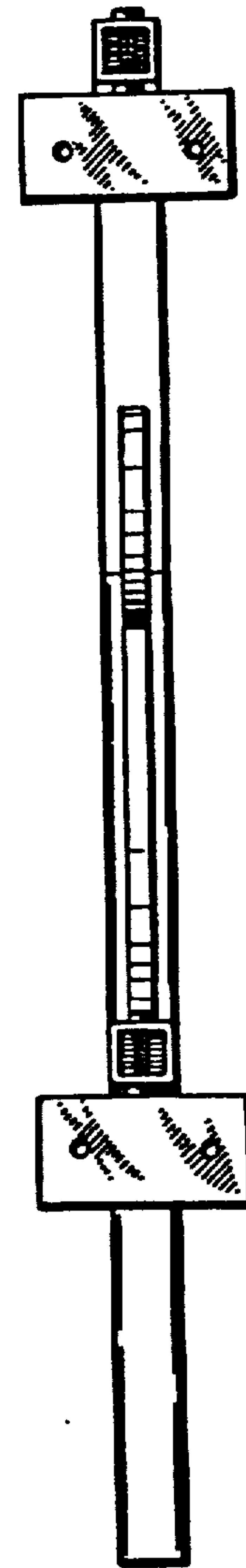
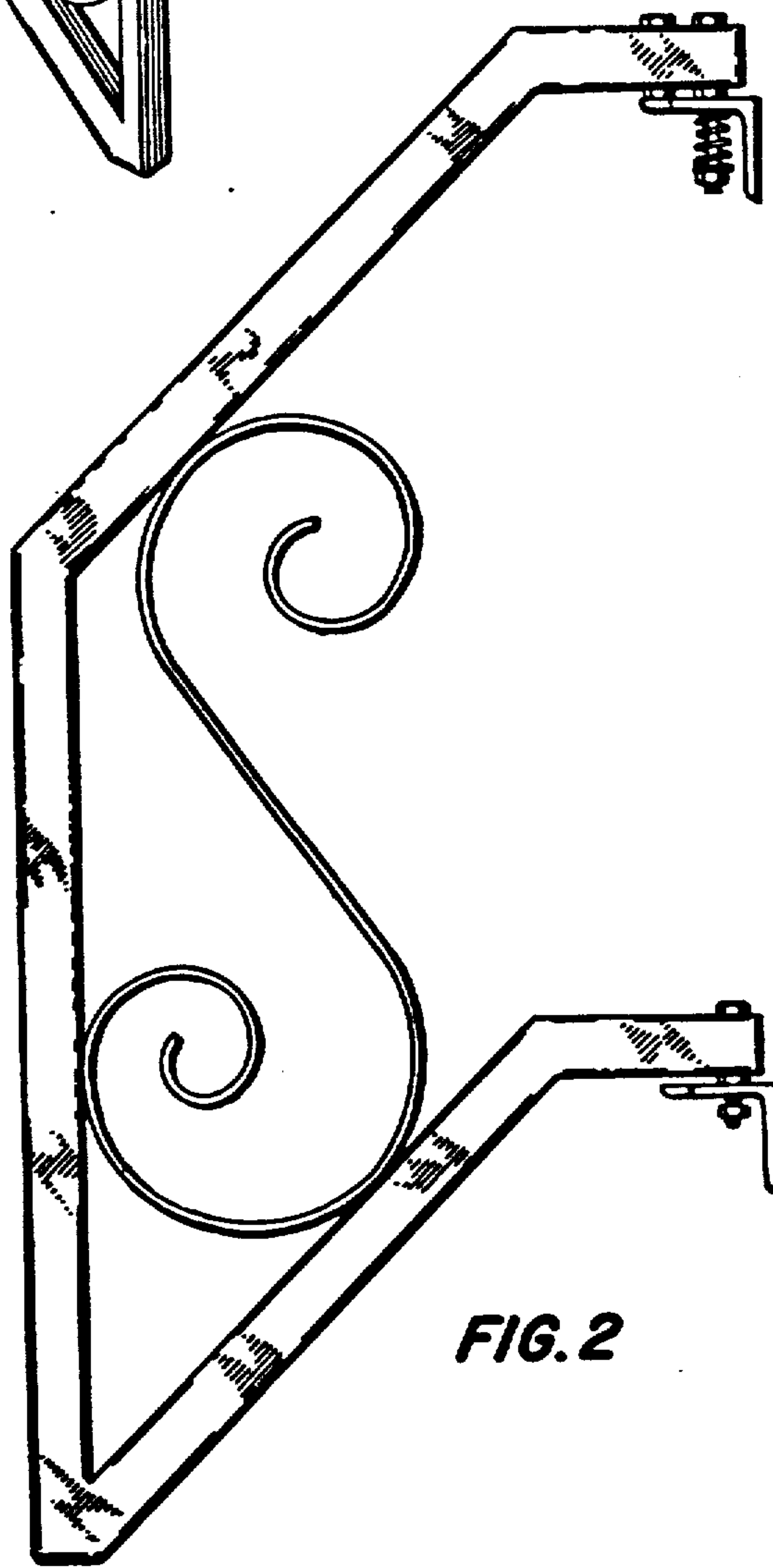
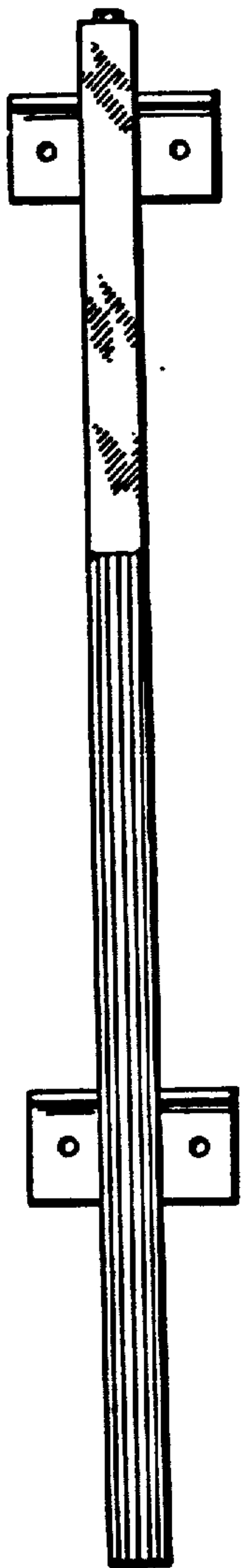
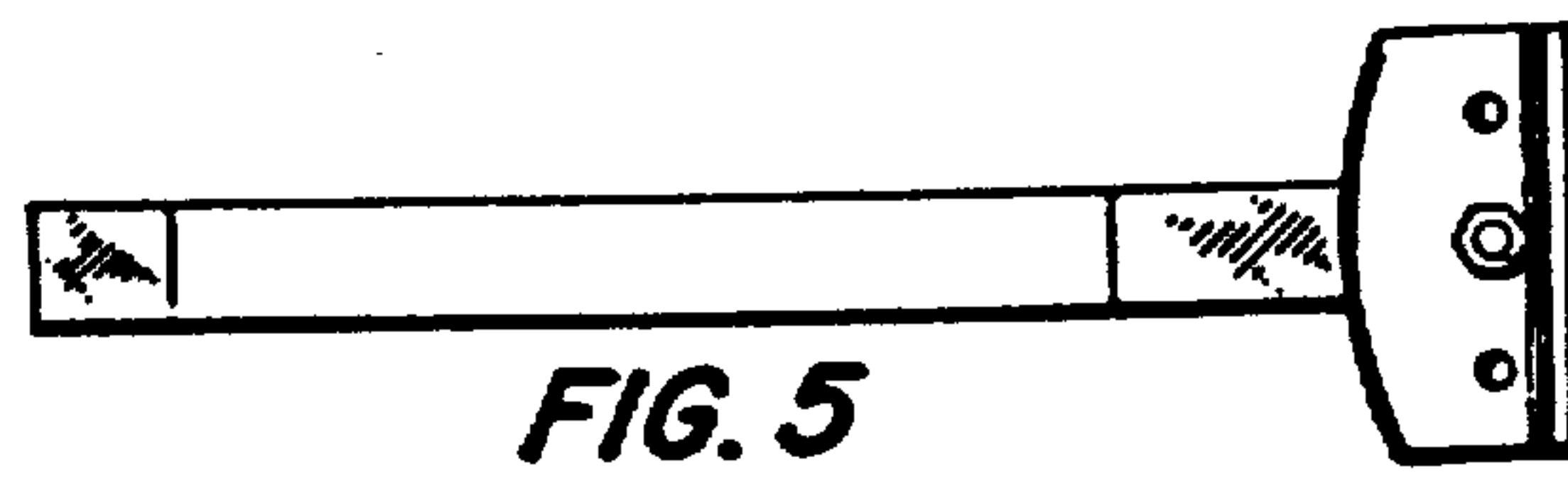
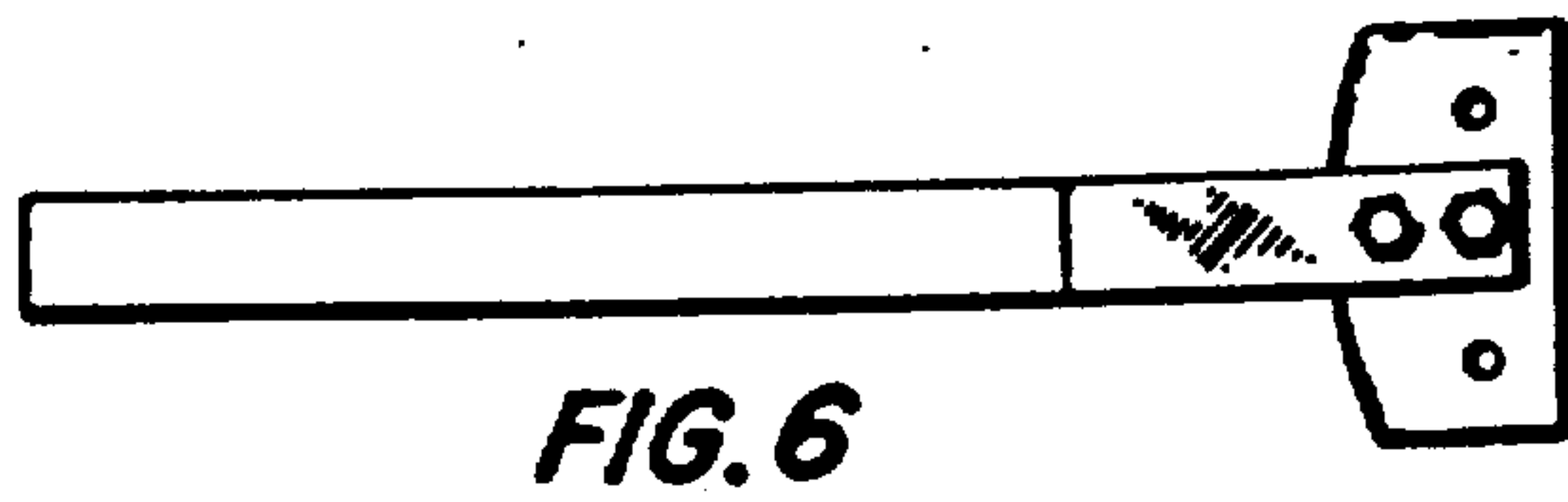
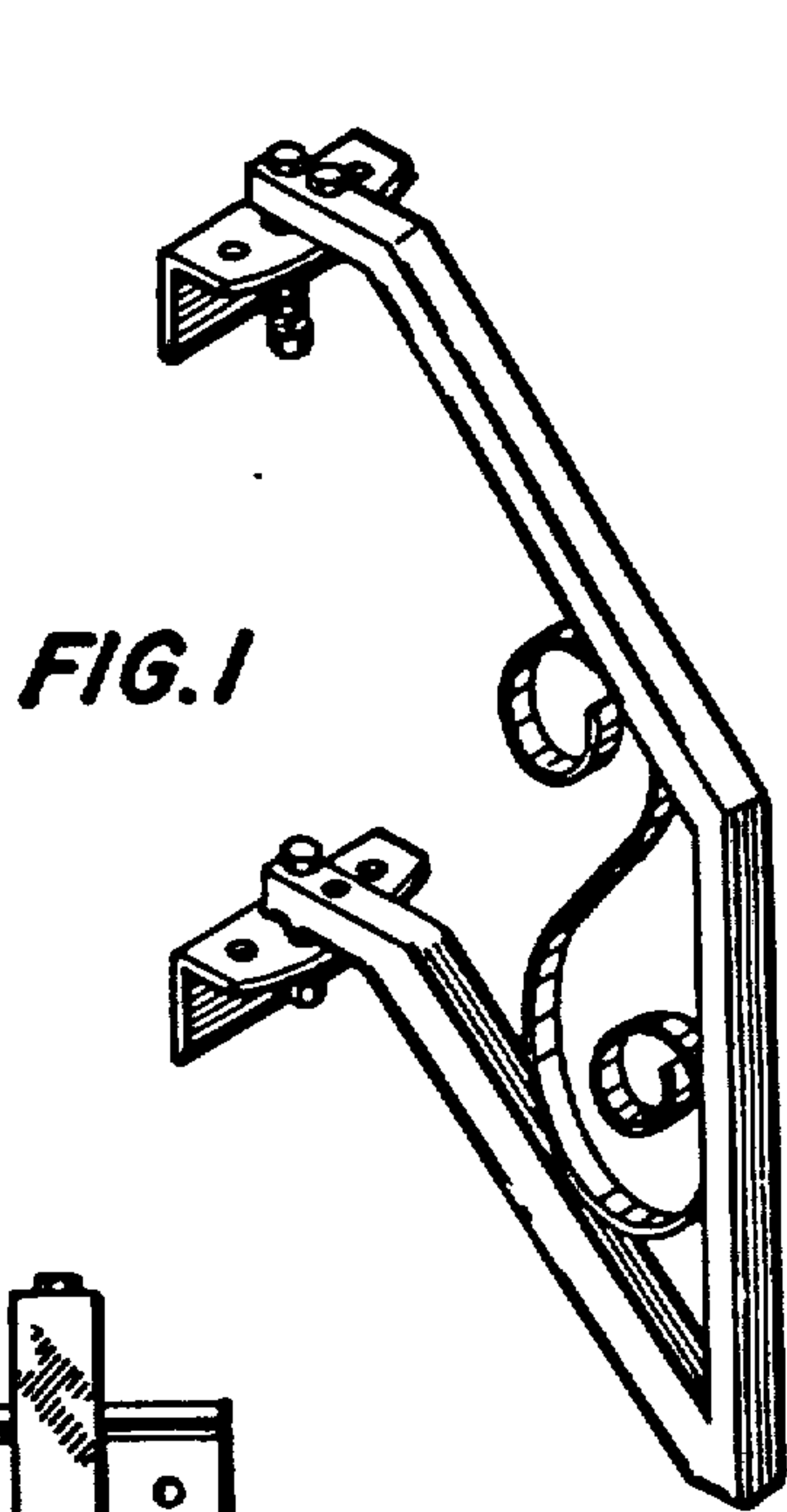

FIG. 3

FIG. 4