

[54] MOTOR VEHICLE STEERING WHEEL

[76] Inventors: Peter O. Marker, 4508 Bates Drive, Yorba Linda, Calif. 92686; Joseph F. King, 5507 Cochin Ave., Arcadia, Calif. 91006

[**] Term: 14 Years

[21] Appl. No.: 571,756

[22] Filed: Apr. 25, 1975

[51] Int. Cl. D12-16

[52] U.S. Cl. D12/176

[58] Field of Search D12/176, 177; 74/552, 74/554, 555, 558, 553

[56] References Cited

U.S. PATENT DOCUMENTS

3,209,615	10/1965	Fosnaugh et al.	74/552
3,909,078	10/1975	Natinsky	74/553
D. 216,543	2/1970	Steele	D12/176
D. 222,768	12/1971	Hikosaburo	D12/176

Primary Examiner—Wallace R. Burke
Assistant Examiner—James M. Gandy
Attorney, Agent, or Firm—Edward J. DaRin

[57] CLAIM

The ornamental design for a motor vehicle steering wheel, as shown and described.

DESCRIPTION

FIG. 1 is a front perspective view of a motor vehicle steering wheel showing our new design;
FIG. 2 is an enlarged top plan view thereof.
FIG. 3 is an enlarged bottom plan view thereof;
FIG. 4 is an enlarged side elevational view thereof;
FIG. 5 is a front perspective view of the horn button bumper ring detached from the motor vehicle steering wheel for clarity of illustration;
FIG. 6 is an enlarged top plan view of FIG. 5;
FIG. 7 is an enlarged bottom plan view of FIG. 5; and
FIG. 8 is an enlarged side elevational view, partially in section of FIG. 5.

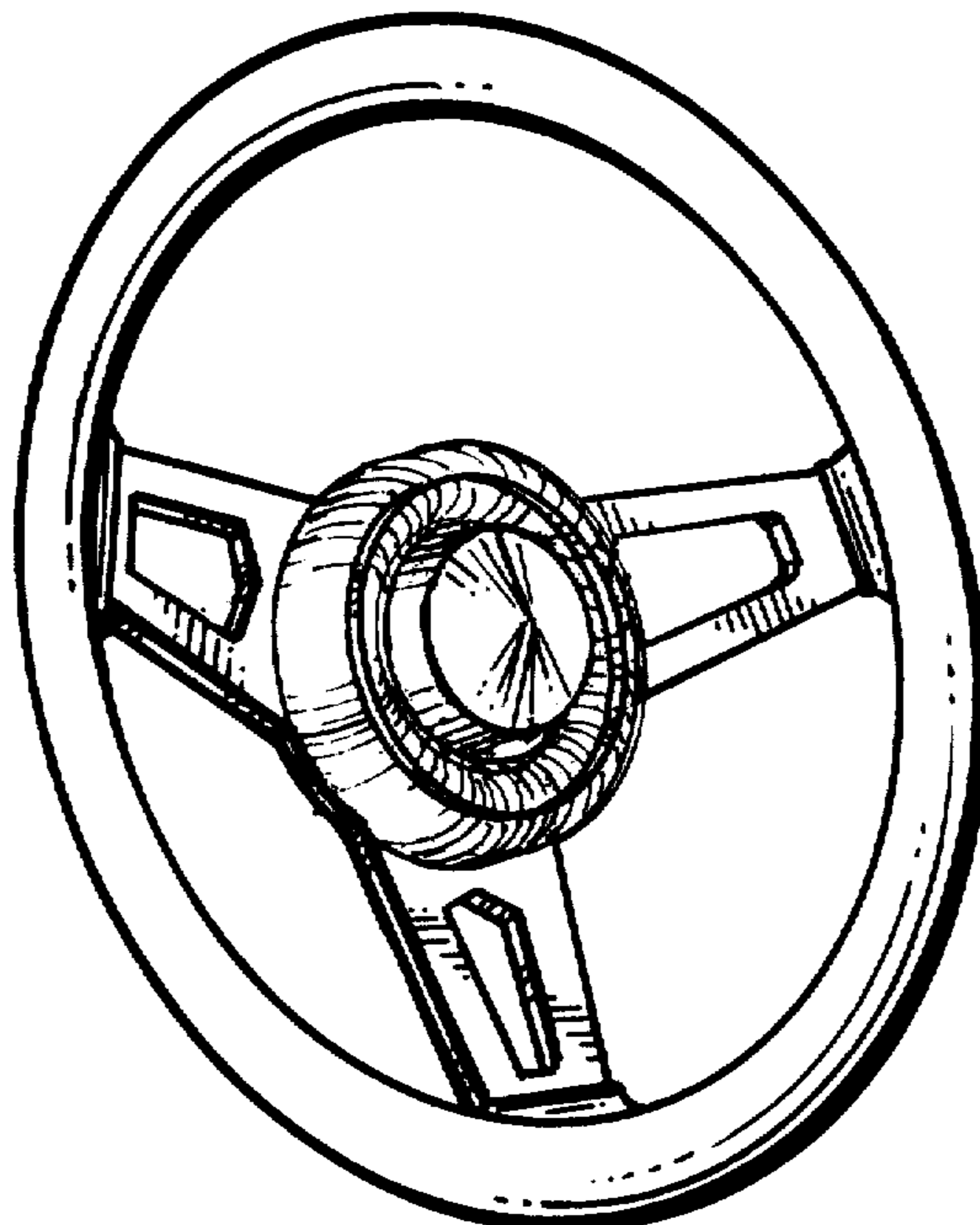

Fig. 1

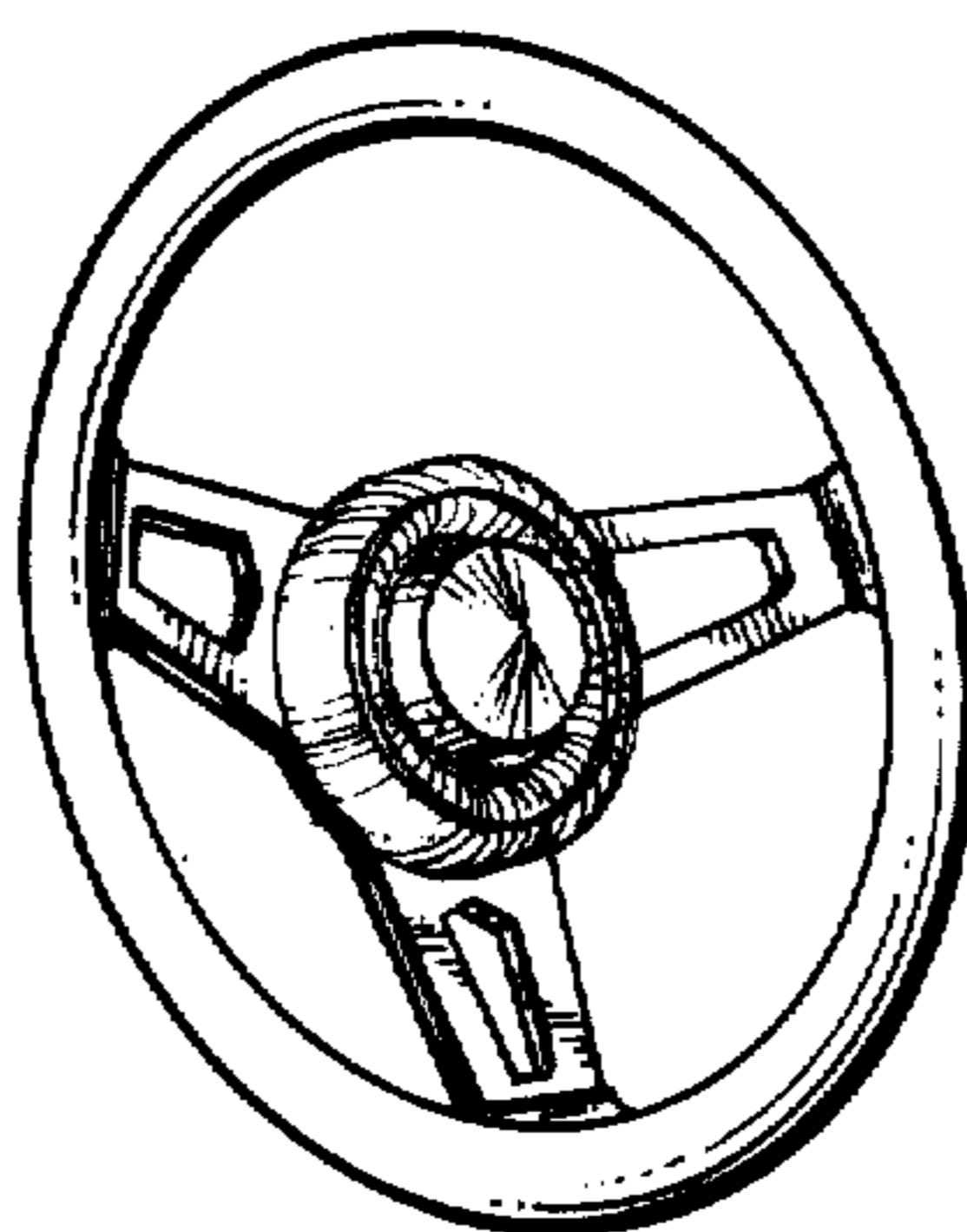

Fig. 2

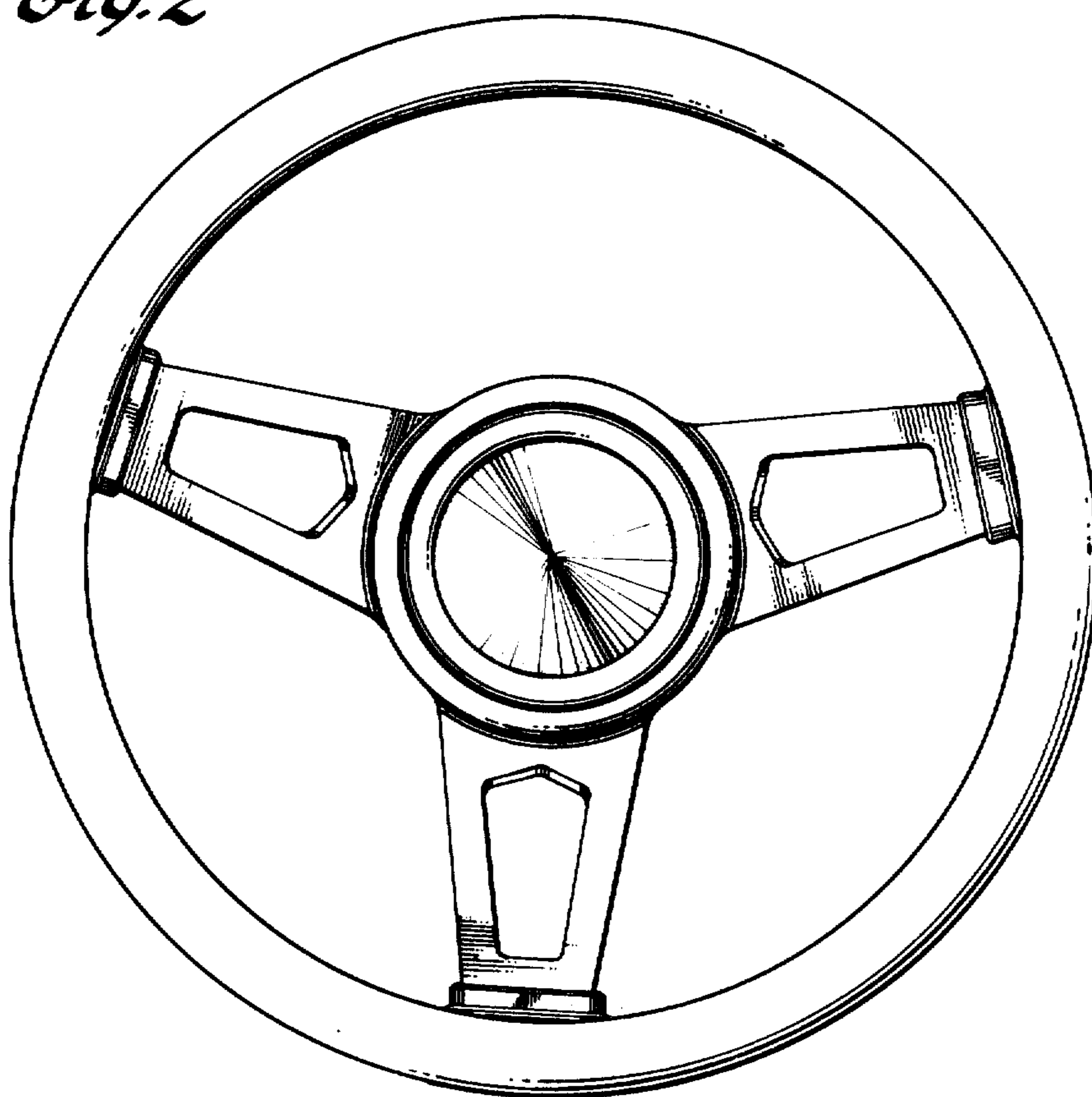

Fig. 4

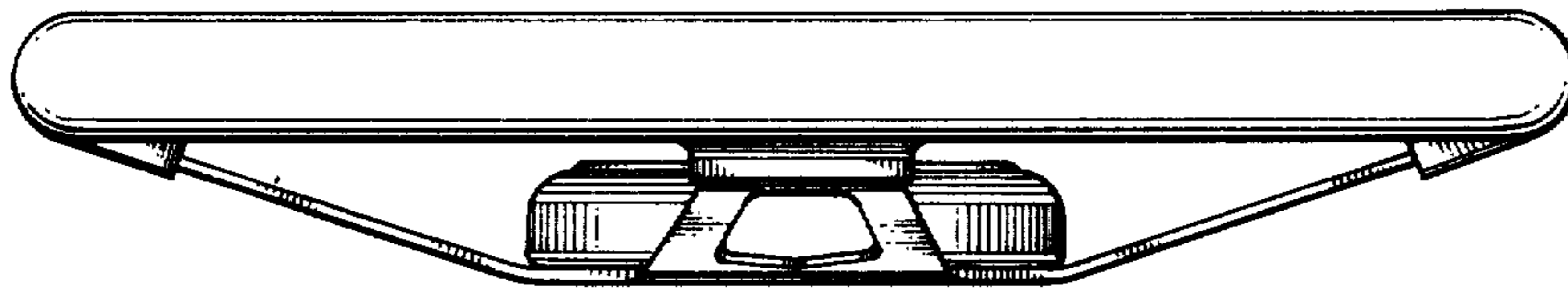

Fig. 3

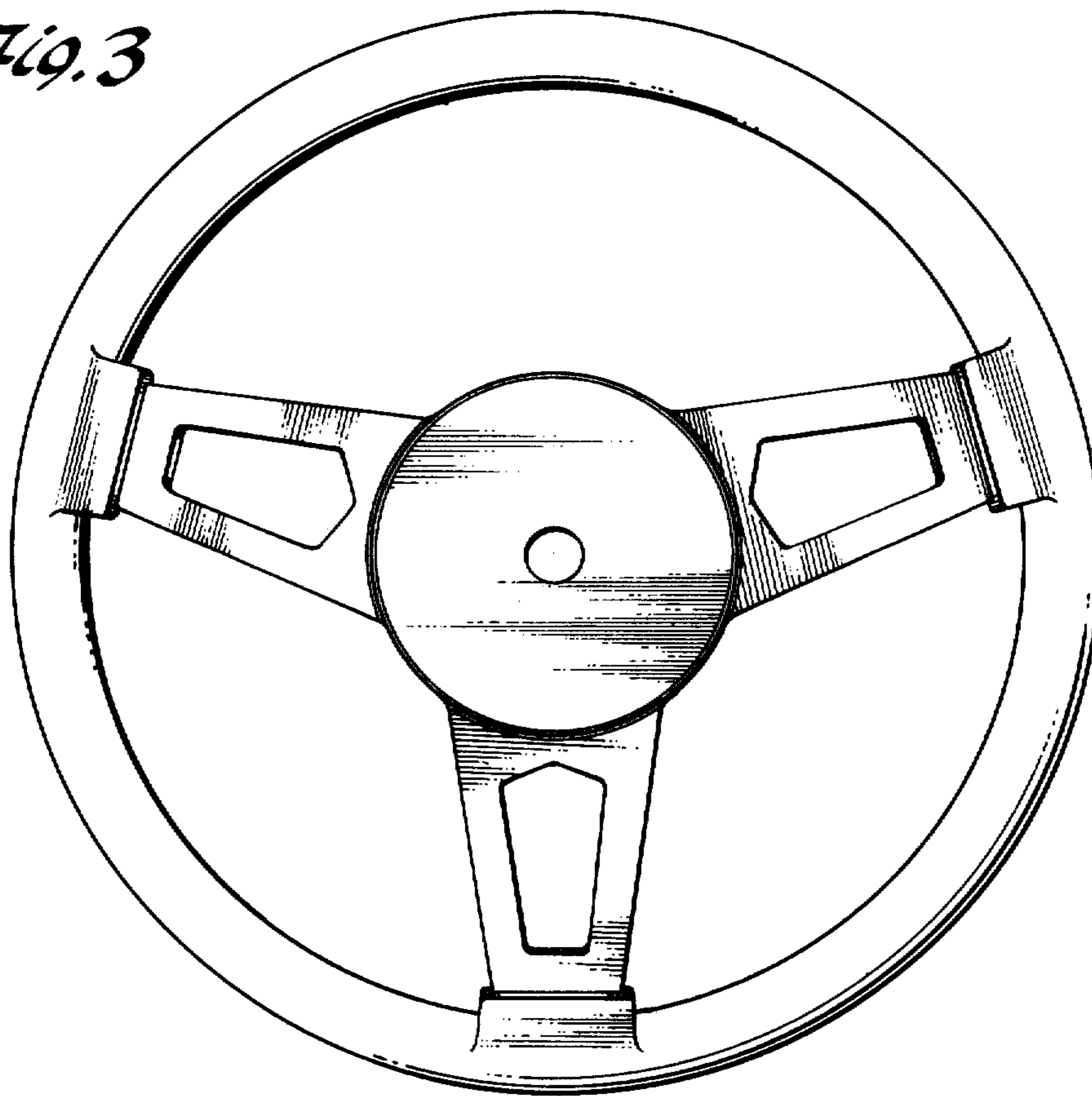

Fig. 5

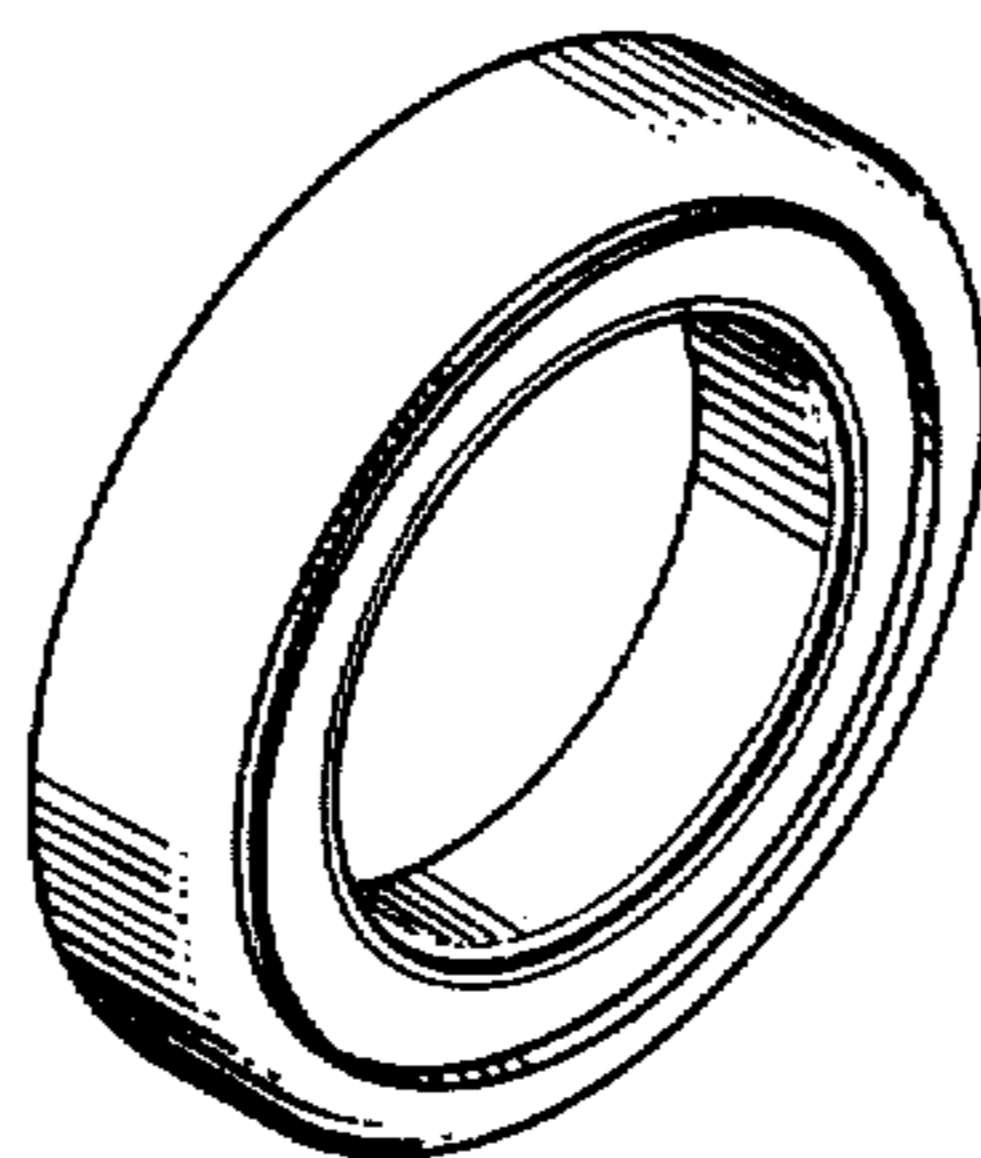

Fig. 6

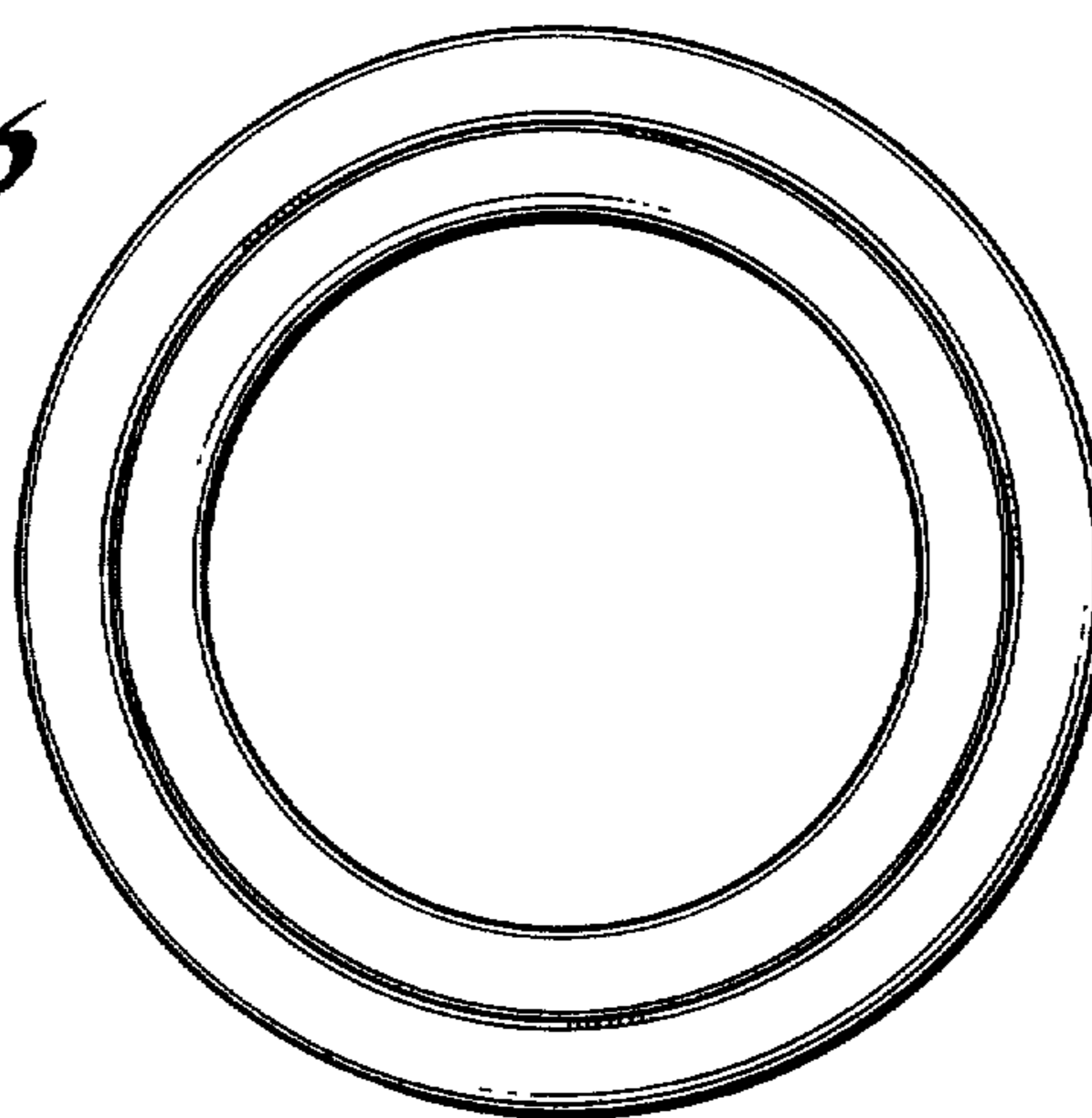

Fig. 8

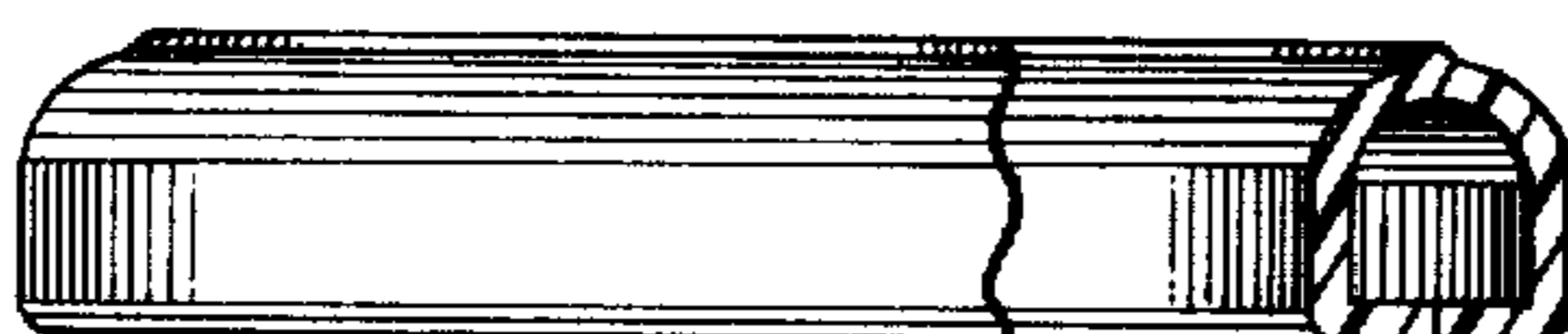

Fig. 7

