

[54] **AUTOMOBILE WIRE WHEEL**
 [75] Inventor: **Merlyn R. Reppert**, Torrance, Calif.
 [73] Assignee: **W. R. Grace & Co.**, New York, N.Y.
 [**] Term: **14 Years**
 [21] Appl. No.: **521,705**
 [22] Filed: **Nov. 7, 1974**
 [51] Int. Cl. **D12-16**
 [52] U.S. Cl. **D12/205**
 [58] Field of Search D12/205; 301/95, 95 B,
 301/95 C, 37 P, 37 CM, 6 CS, 37 SS, 37 R, 56,
 63 R, 63 PW, 64 R, 64 SD, 65, 66, 73, 79

[56] **References Cited**

U.S. PATENT DOCUMENTS

D. 231,732 6/1974 Ishibashi D12/209
 D. 233,328 10/1974 Clary et al. D12/205

FOREIGN PATENT DOCUMENTS

287,085 12/1928 United Kingdom 301/9.5 B
 357,573 9/1931 United Kingdom 301/9.5 B

OTHER PUBLICATIONS

Motor Trend, 9/72, p. 75, Wire Wheel, bottom of page.

Road and Track, 4/72, p. 49, Wire Wheel, bottom of page.
 Modern Tire Dealer, 3/73, p. 11, Wire Wheel, top right side of page.
 Road and Track, 10/72, p. 69, Wire Wheel, top left side of page.
 Modern Tire Dealer Annual Products Catalog, Mid-Apr. 1974, p. 38, Wire Spoke Wheel, center right side of page.

Primary Examiner—Wallace R. Burke
Assistant Examiner—James M. Gandy
Attorney, Agent, or Firm—Charles L. Harness

[57] **CLAIM**

The ornamental design for an automobile wire wheel, as shown.

DESCRIPTION

FIG. 1 is a front elevational view of an automobile wire wheel showing my new design;
 FIG. 2 is a rear elevational view thereof; and
 FIG. 3 is a cross-sectional view thereof taken along the line 3-3 in FIG. 1, it being understood that the rear spokes have been omitted for clarity of illustration.

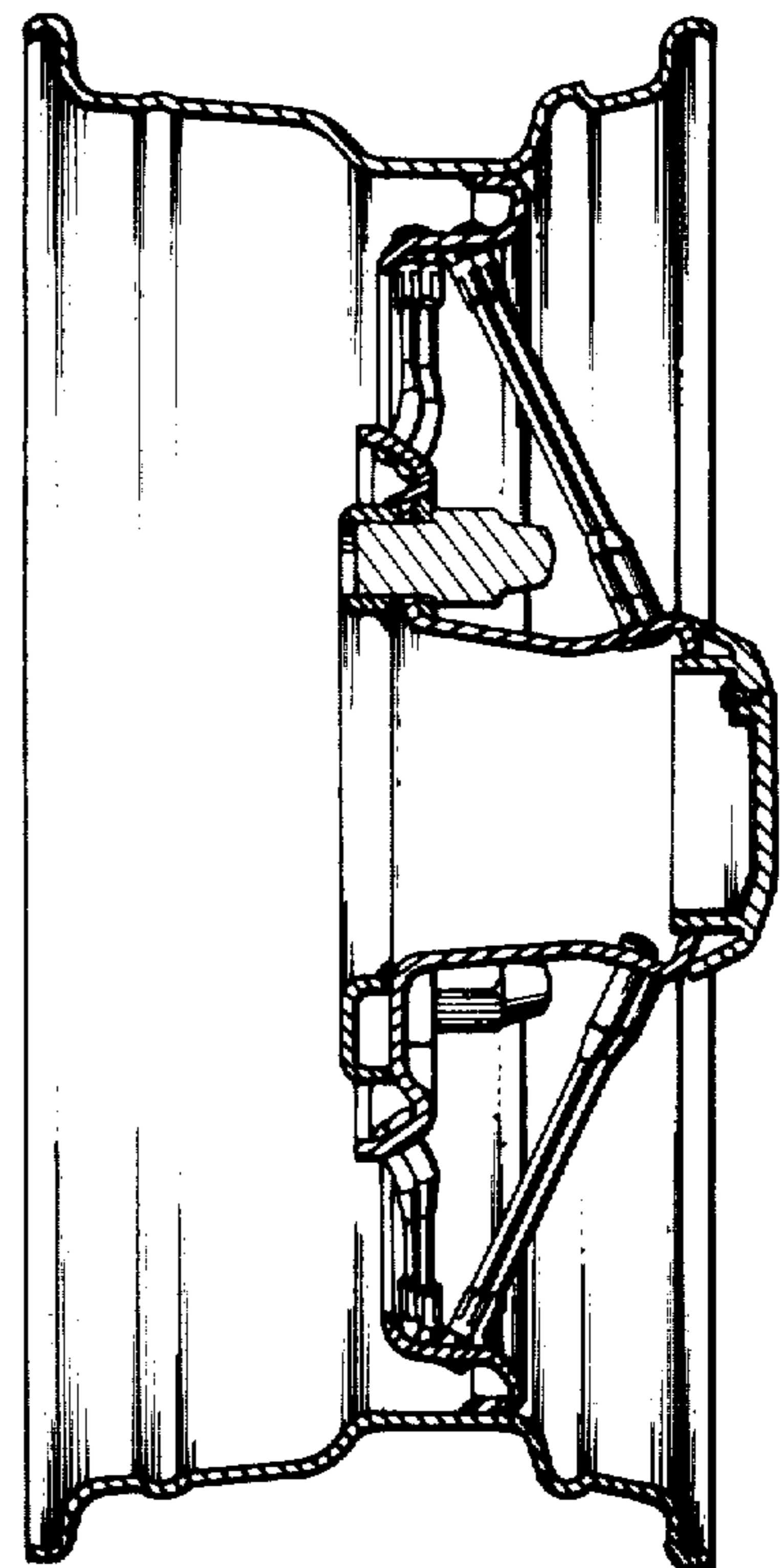
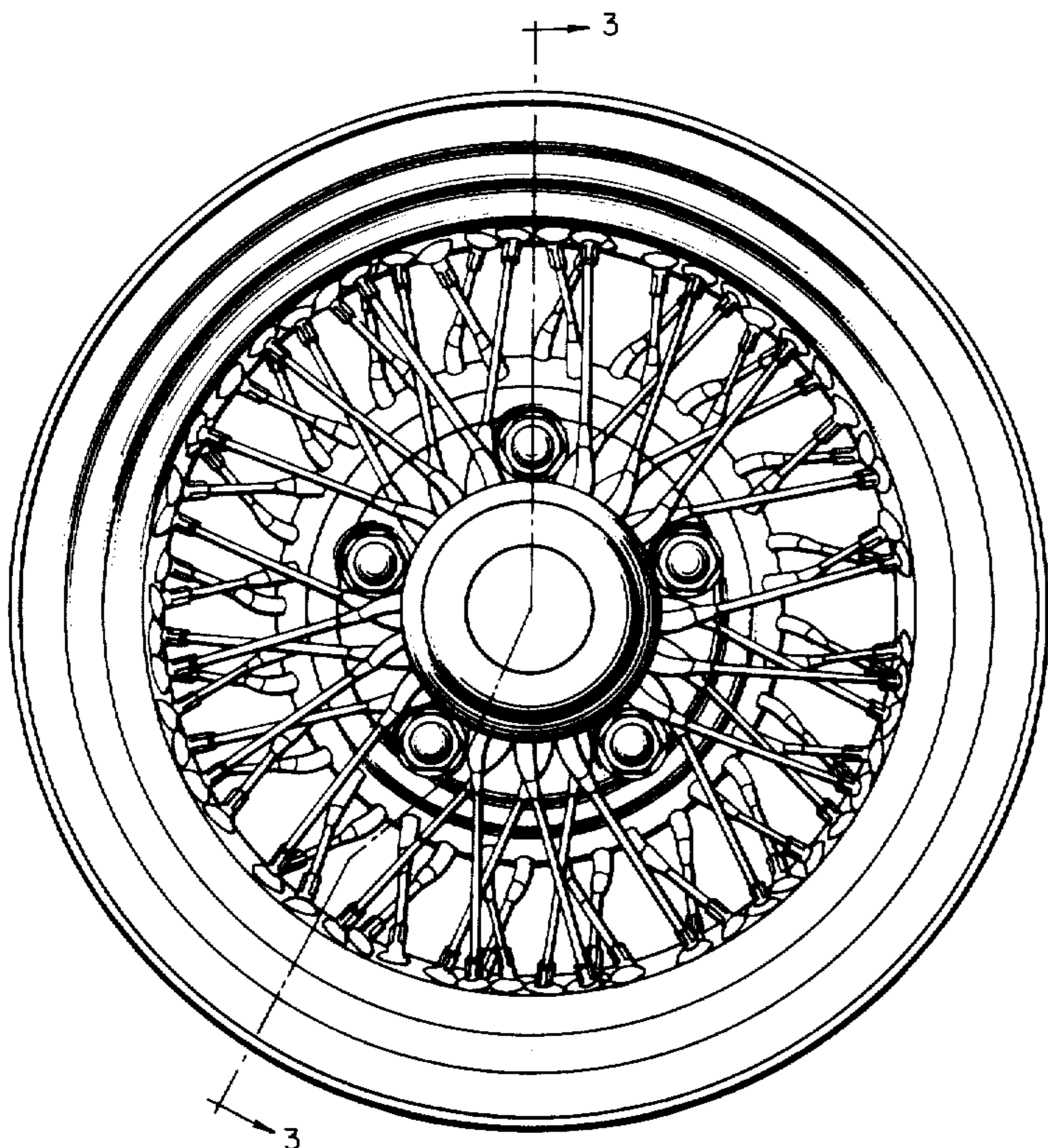

FIG. 1

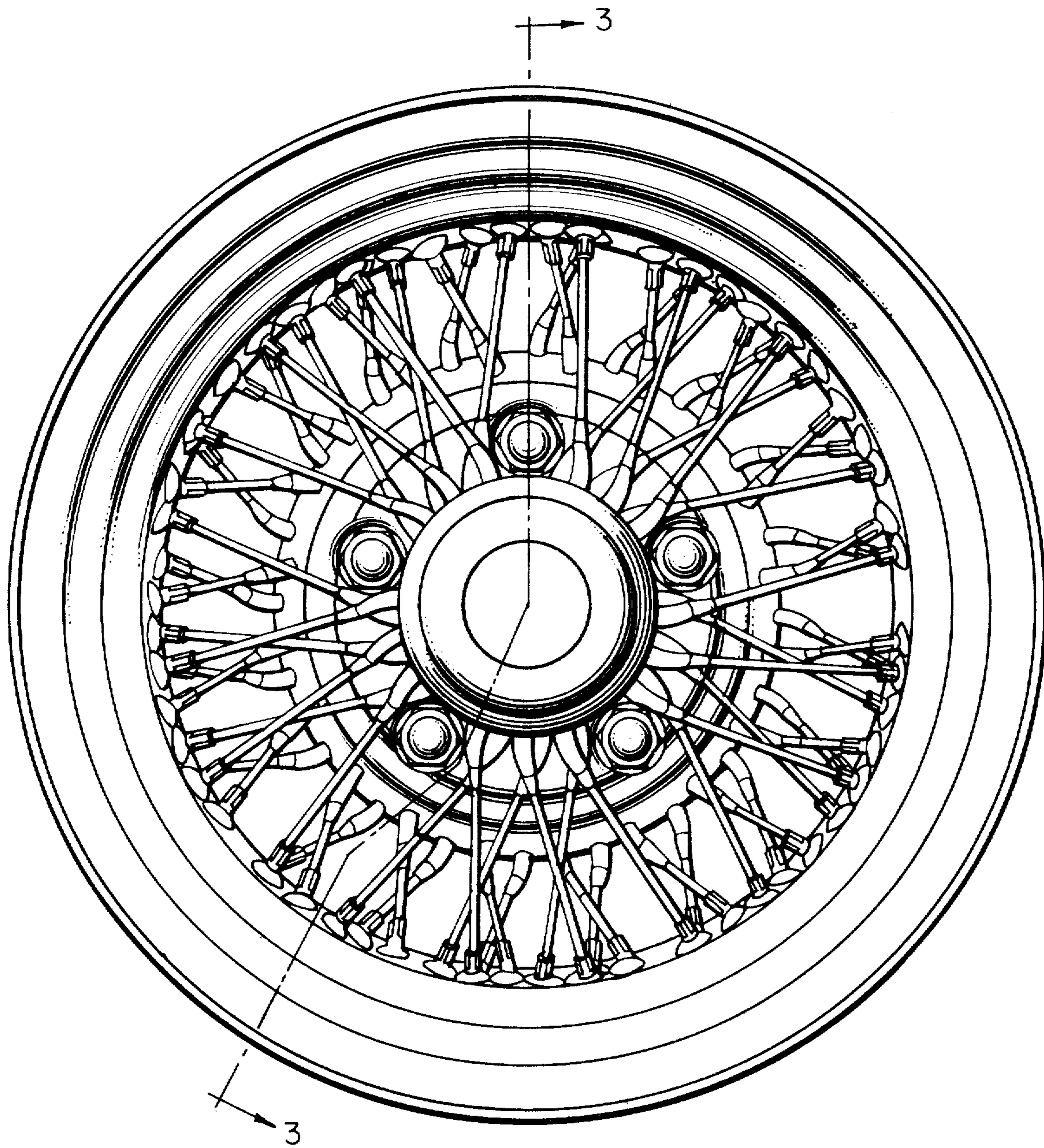

FIG. 2

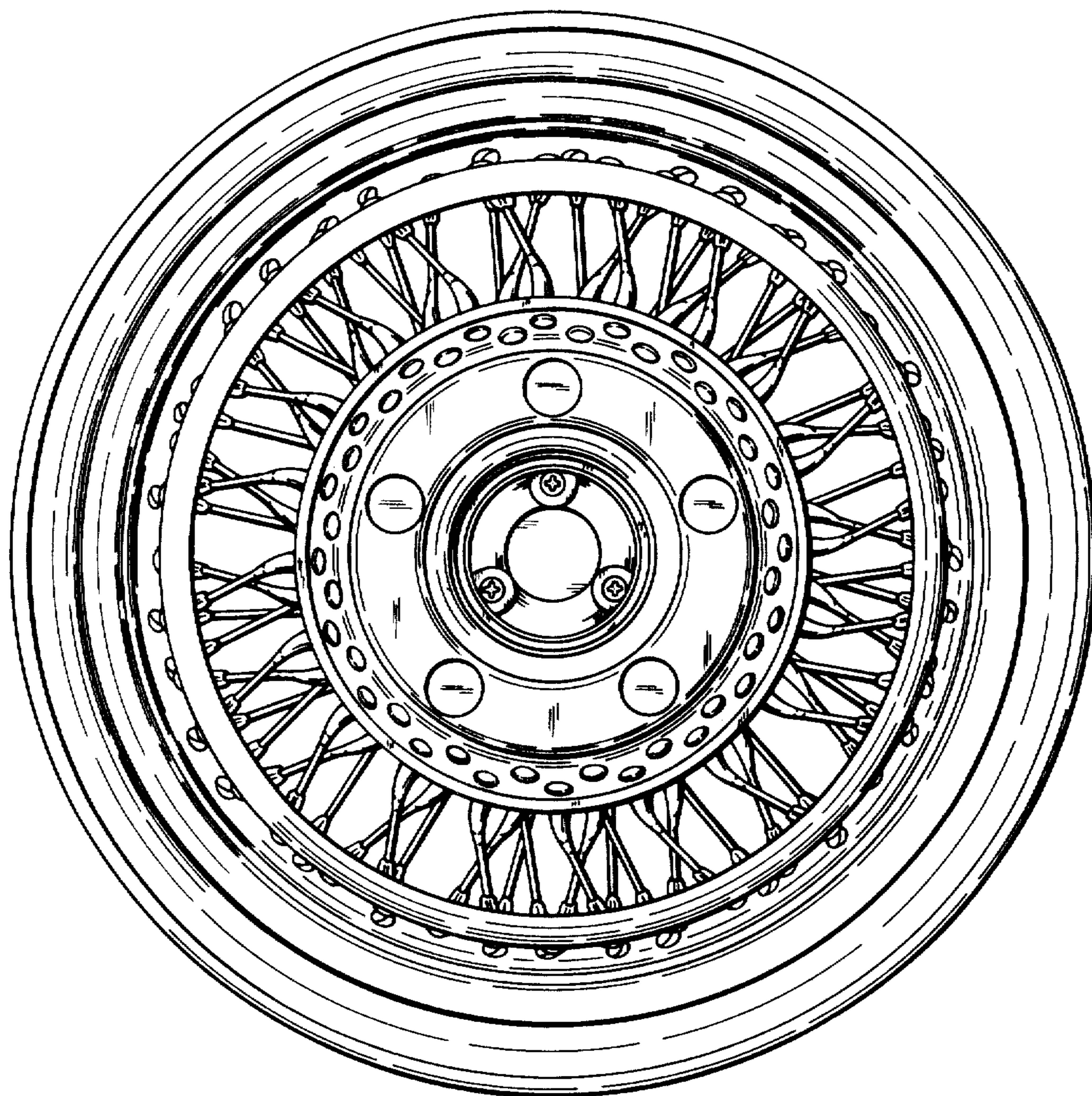

FIG. 3

