

[54] TRUCK

[76] Inventor: Harold Isaacs, 2567 Lafayette Drive, University Heights, Ohio 44118

[**] Term: 14 Years

[21] Appl. No.: 605,744

[22] Filed: Aug. 18, 1975

[51] Int. Cl. D12-08

[52] U.S. Cl. D12/96

[58] Field of Search D12/96, 98, 99; 180/89 R, 89 A; 296/28 C, 28 M

[56] References Cited

U.S. PATENT DOCUMENTS

D. 168,576 1/1953 Lee D12/96
D. 173,314 10/1954 Kramer D12/96

FOREIGN PATENT DOCUMENTS

684,351 4/1964 Canada 296/28 M

OTHER PUBLICATIONS

Modern Materials Handling, 6/66, p. 117, Tow Tractor, Top right side of page.
Commercial Car Journal, 6/53, p. 174, Truck, Top left side of page.

Primary Examiner—Susie J. Mercer
Assistant Examiner—James M. Gandy
Attorney, Agent, or Firm—Edward E. Sachs

[57] CLAIM

The ornamental design for a truck, substantially as shown and described.

DESCRIPTION

FIG. 1 is a front elevational view of a truck showing my new design;
FIG. 2 is a side elevational view thereof to a reduced scale;
FIG. 3 is a side elevational view thereof to a reduced scale of the side opposite to that shown in FIG. 2; and
FIG. 4 is a perspective view thereof to a greatly reduced scale.
The rear of the truck is substantially flat and unornamented.

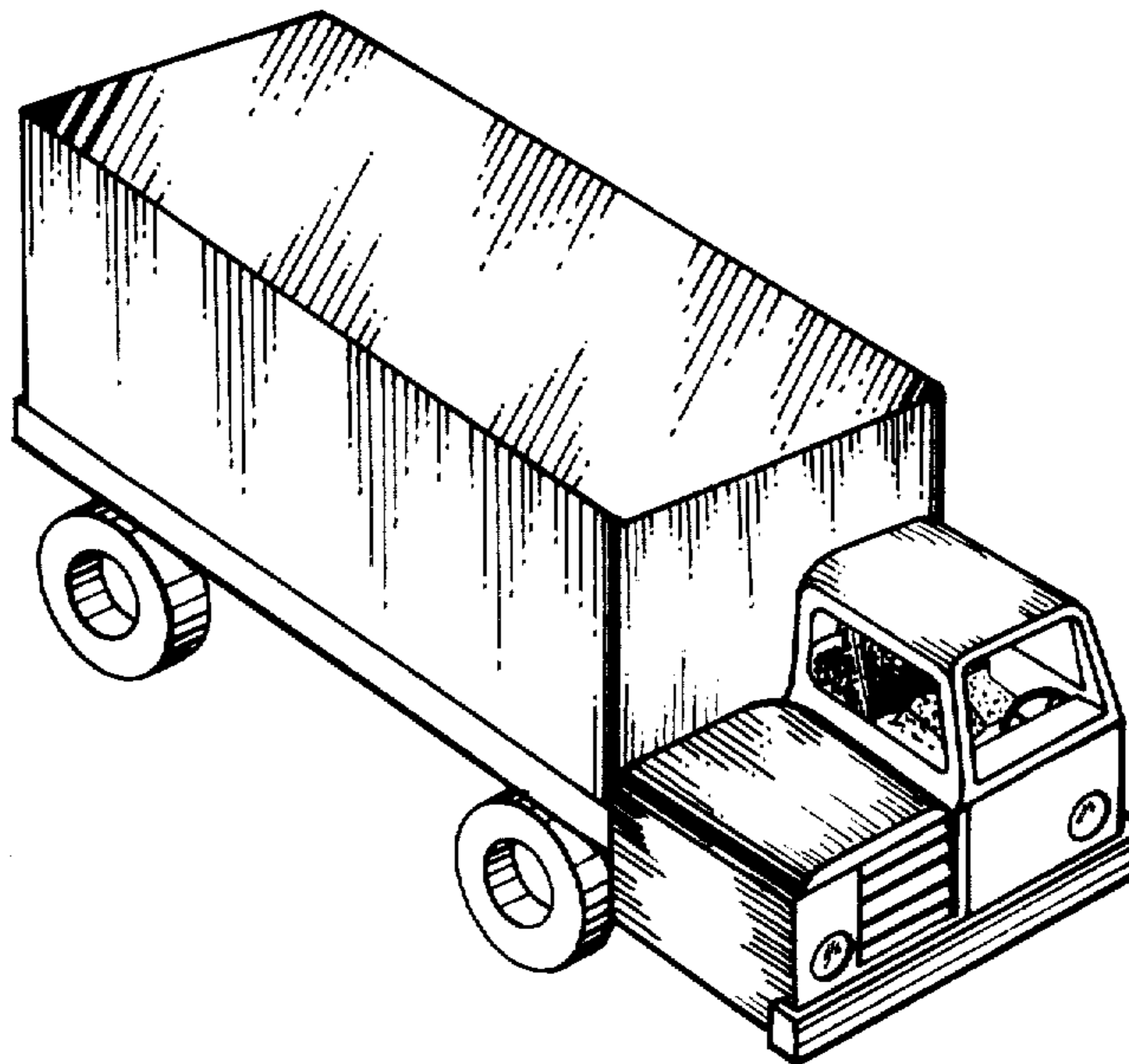

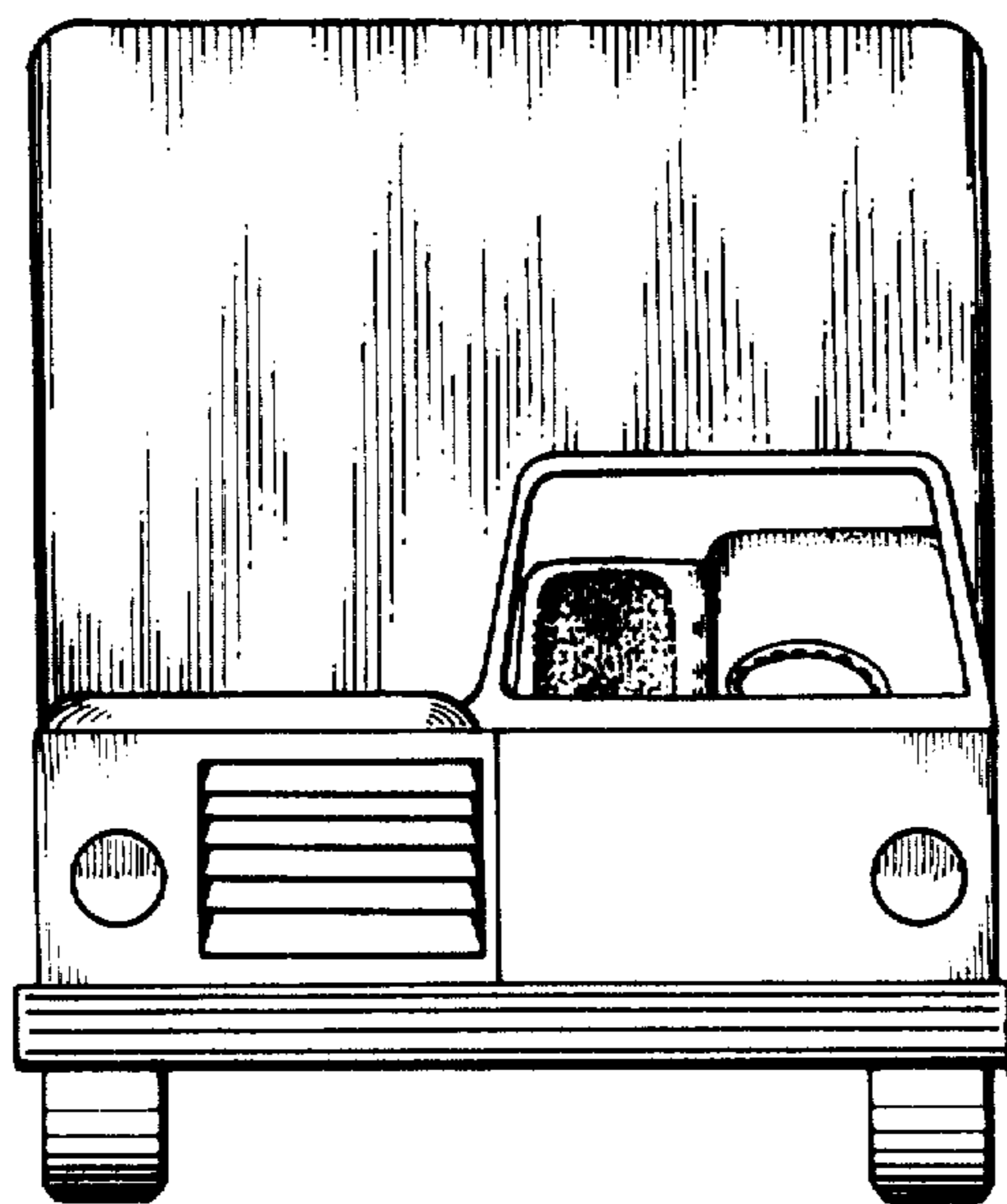

FIG. 1

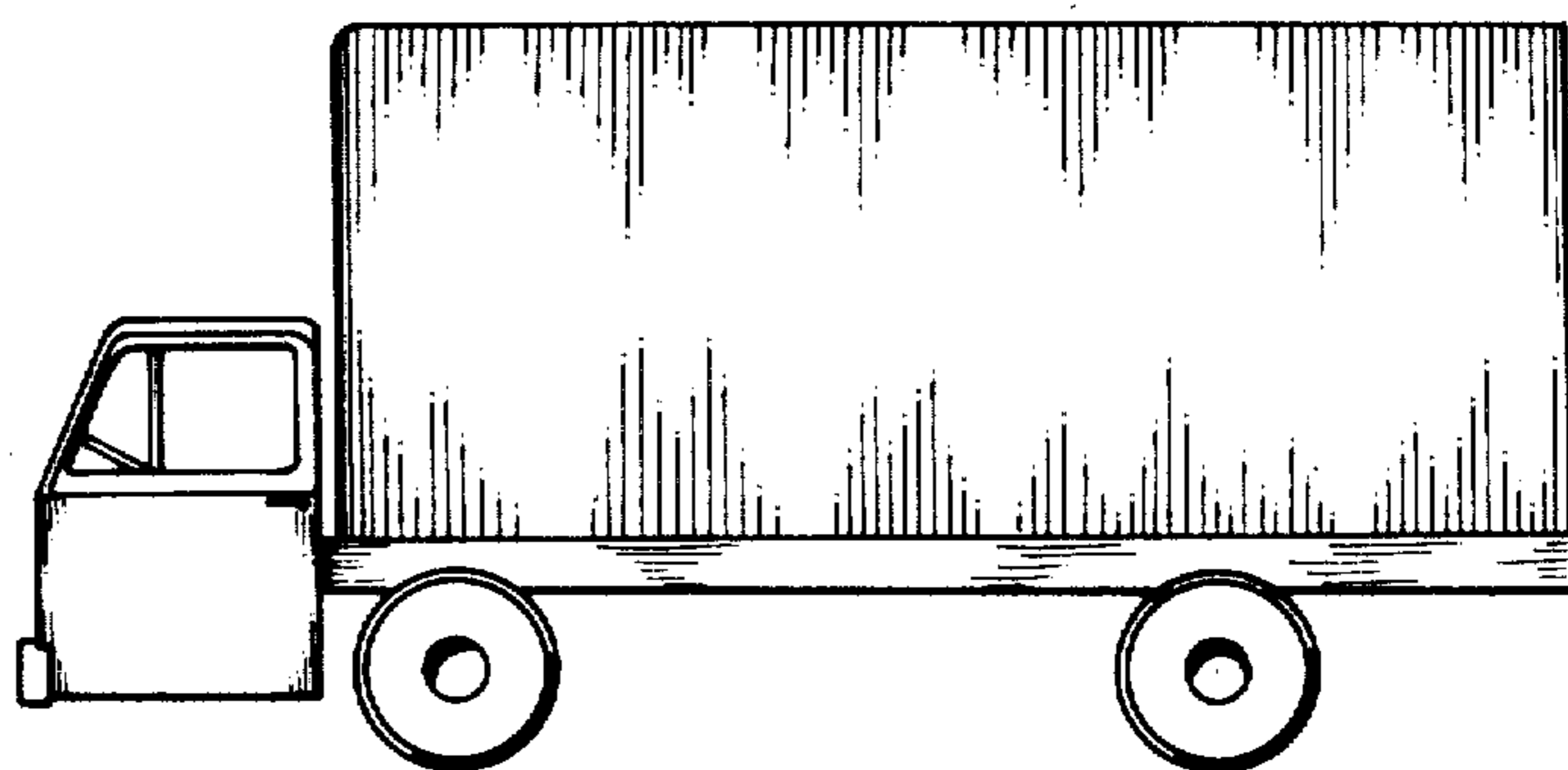

FIG. 2

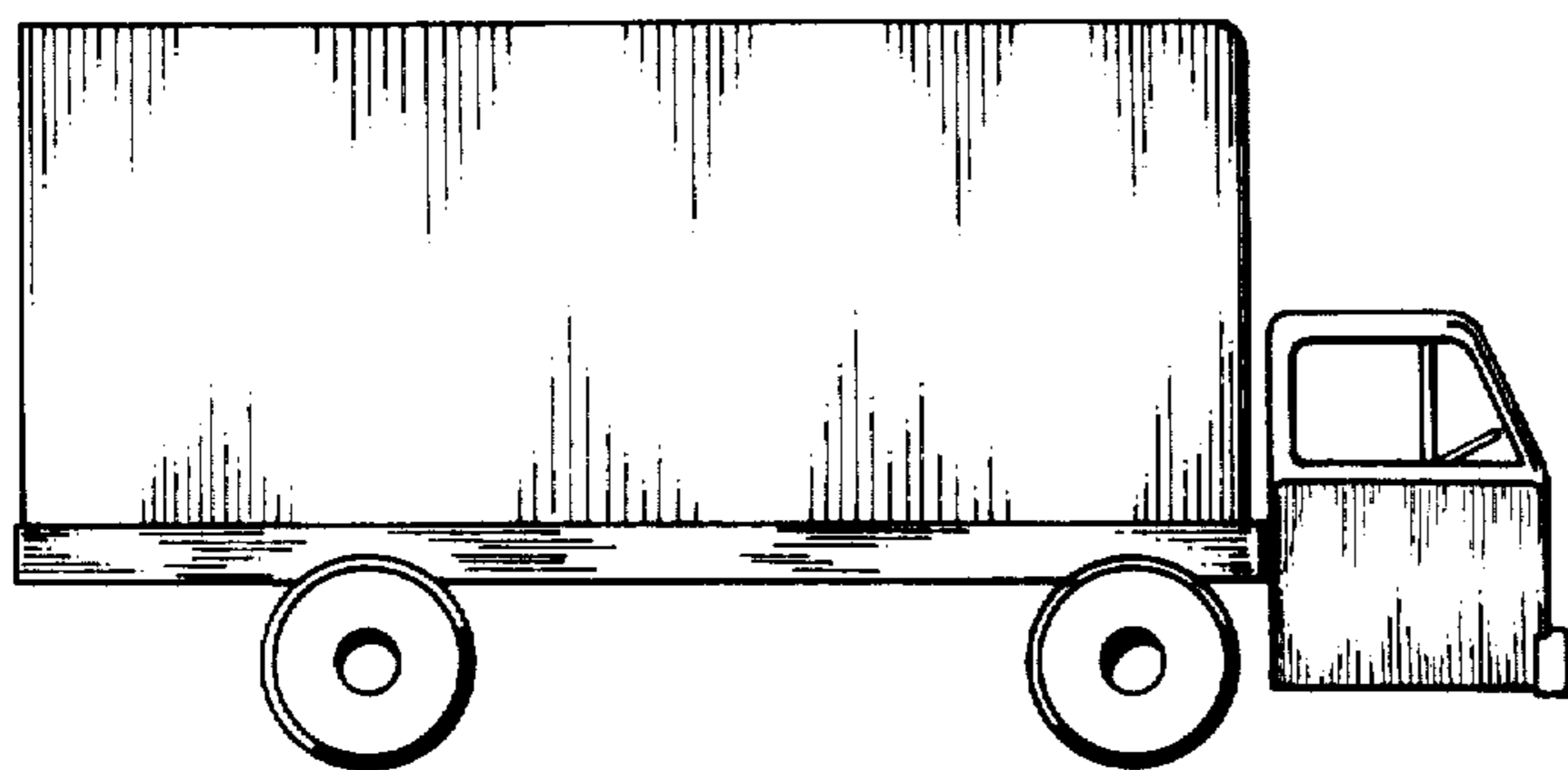

FIG. 3

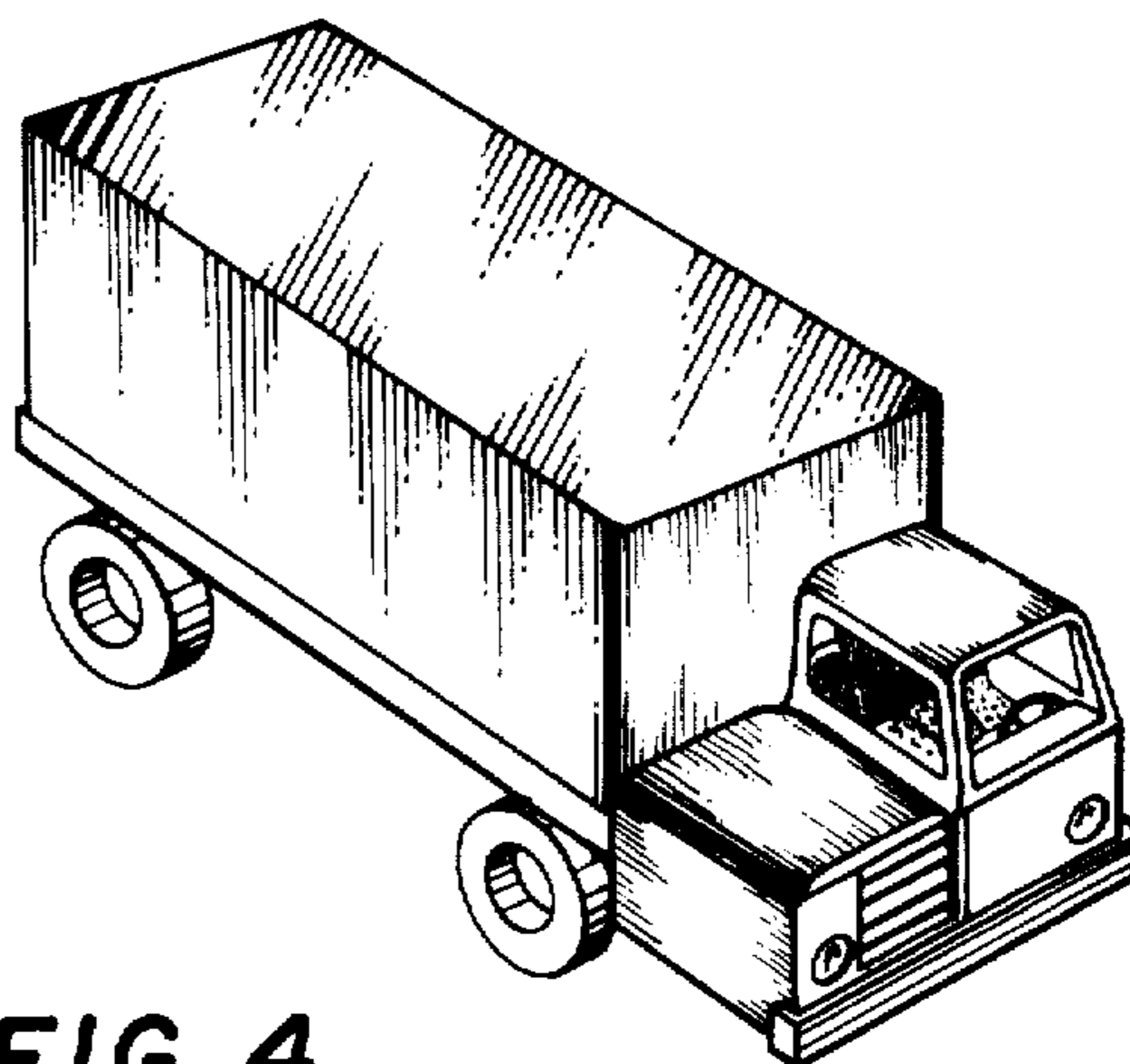

FIG. 4