

[54] TOY TRUCK WITH PLOW

[75] Inventors: Jack L. Breneman, Orchard Park; Jeffrey T. Samson, East Aurora, both of N.Y.

[73] Assignee: The Quaker Oats Company, Chicago, Ill.

[**] Term: 14 Years

[21] Appl. No.: 506,102

[22] Filed: Sept. 16, 1974

[51] Int. Cl. D21-01

[52] U.S. Cl. D34/15 AJ

[58] Field of Search D34/15 AJ, 15 D, 15 W, D34/15 AA, 15 BB, 15 HS, 15 JJ, 15 AF; D12/15, 75, 72, 73; D40/1 R; 280/1 R; 46/214, 222, 204

[56] References Cited

U.S. PATENT DOCUMENTS

D. 235,528 6/1975 Ahola et al. D12/15

OTHER PUBLICATIONS

Ertl Catalog, 1968, p. 3, "I. H. Pay Hauler," At Left Side of Page.

Wiking Catalog, 1969, p. 2, Item No. 64K, "Kom-munal-Unimog".
Wards Catalog, 1960, p. 626, "Shockmaster Fork," at Center of Page.

Primary Examiner—Joel Stearman
Assistant Examiner—C. A. Rademaker
Attorney, Agent, or Firm—Cumpston, Shaw & Stephens

[57] CLAIM

The ornamental design for a toy truck with plow, substantially as shown and described.

DESCRIPTION

FIG. 1 is a front perspective view of a toy truck with plow showing our new design; FIG. 2 is a left-side elevational view thereof; FIG. 3 is a front elevational view thereof; FIG. 4 is a rear elevational view thereof; and, FIG. 5 is a top plan view thereof. The tire lugs fragmentarily shown in FIG. 1 are continuous over the surface of the tire. The bottom plan aspect of the toy truck with plow is substantially plain and unornamented.

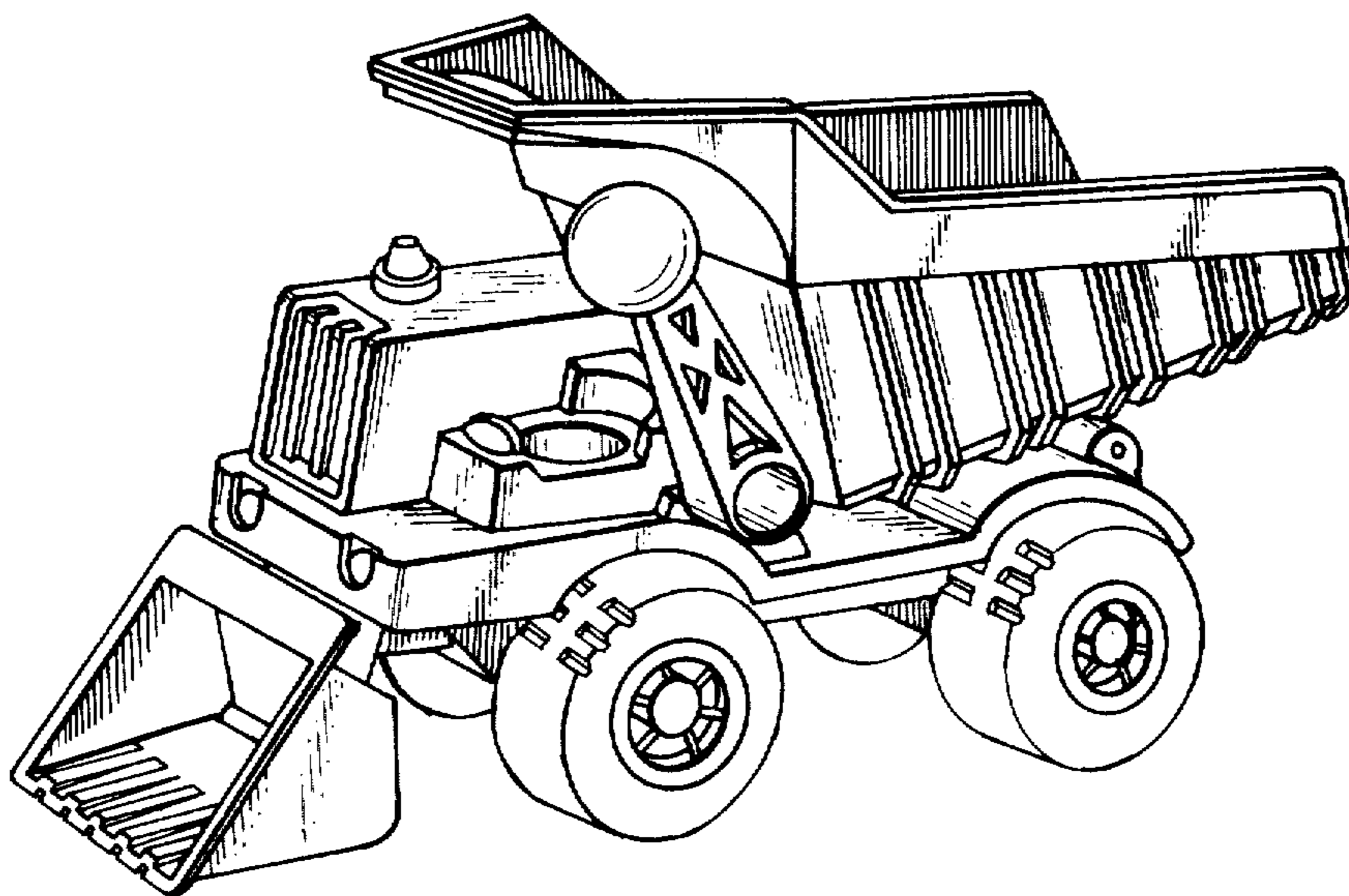

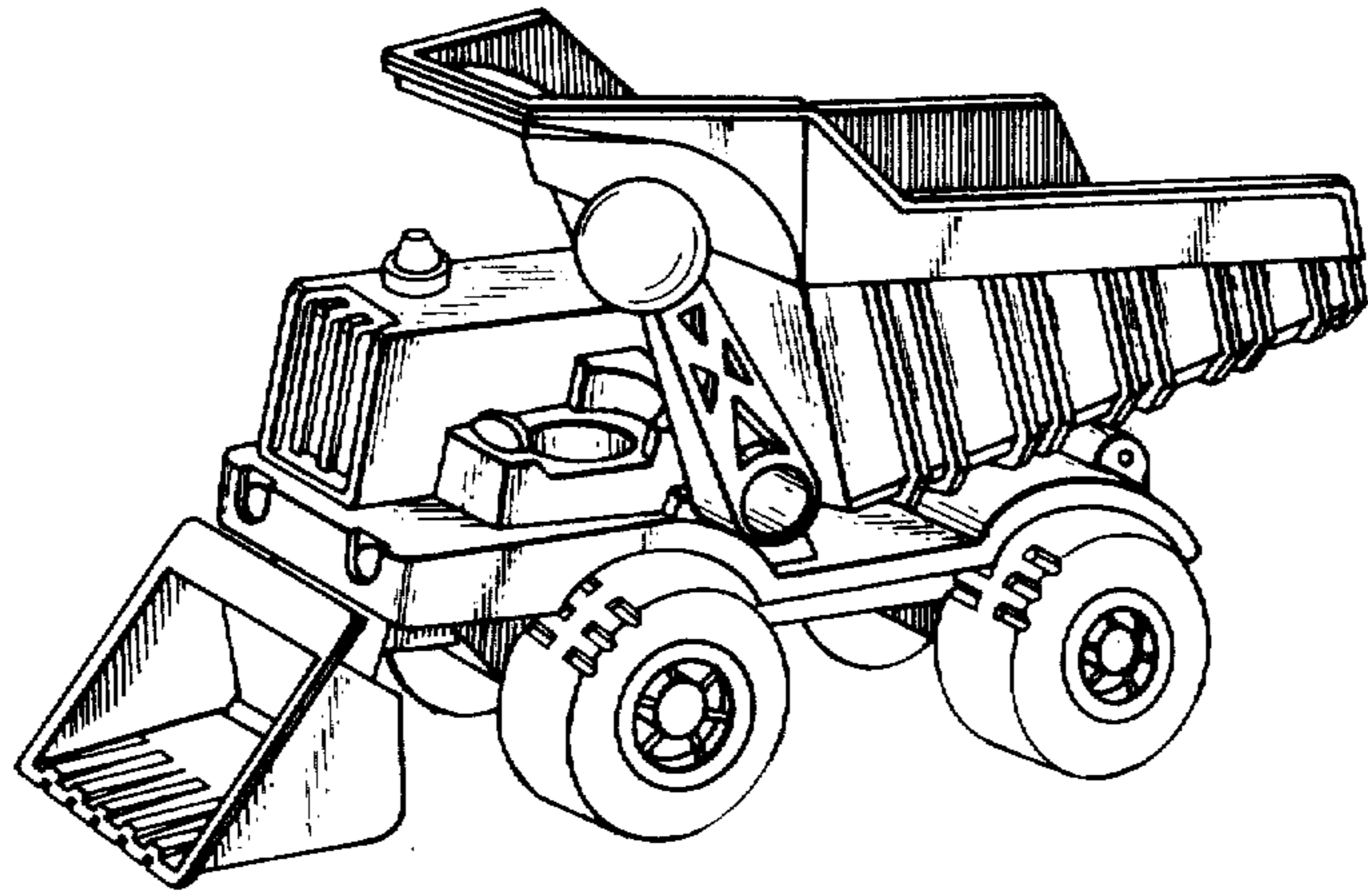

FIG. 1

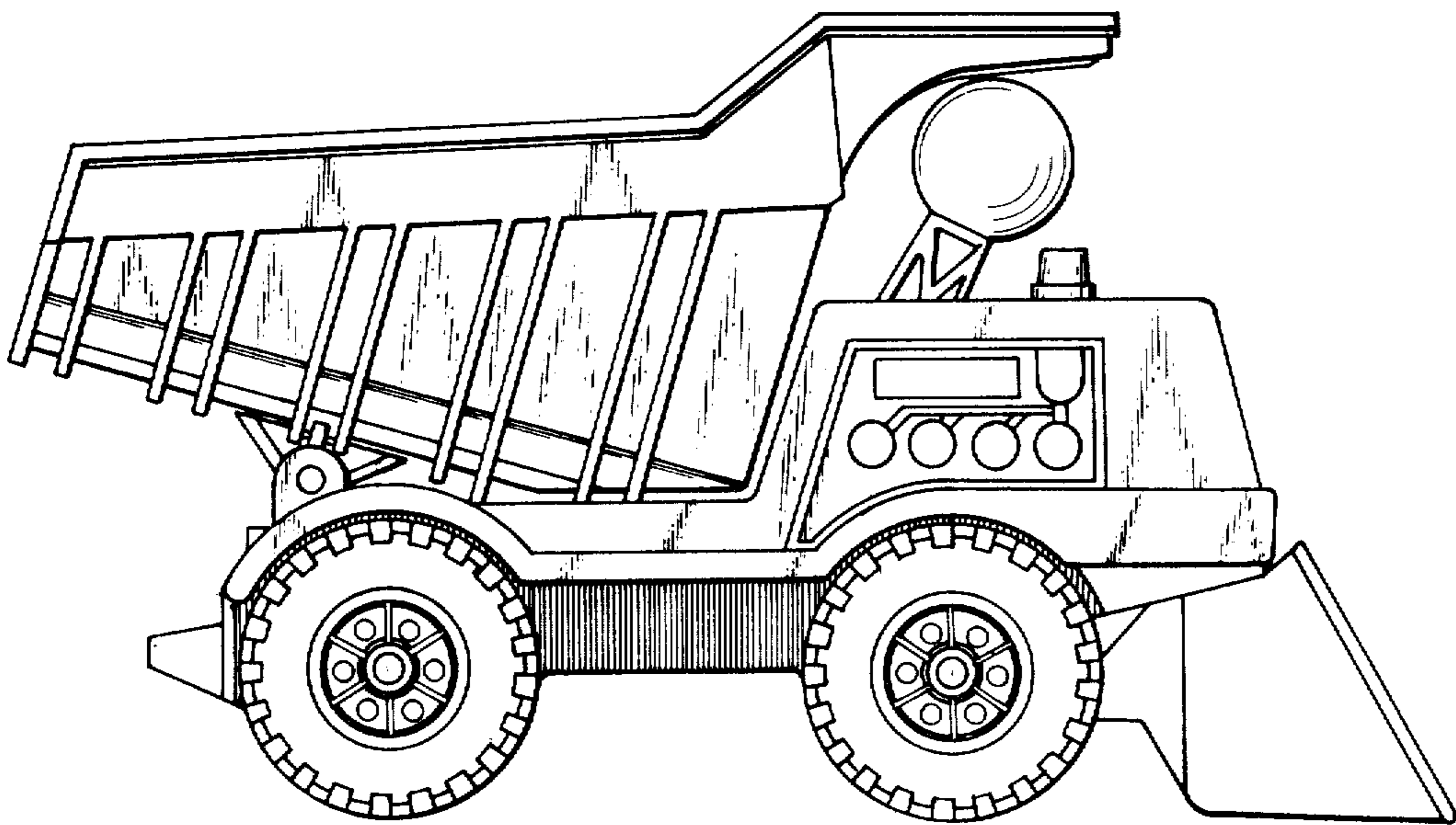

FIG. 2

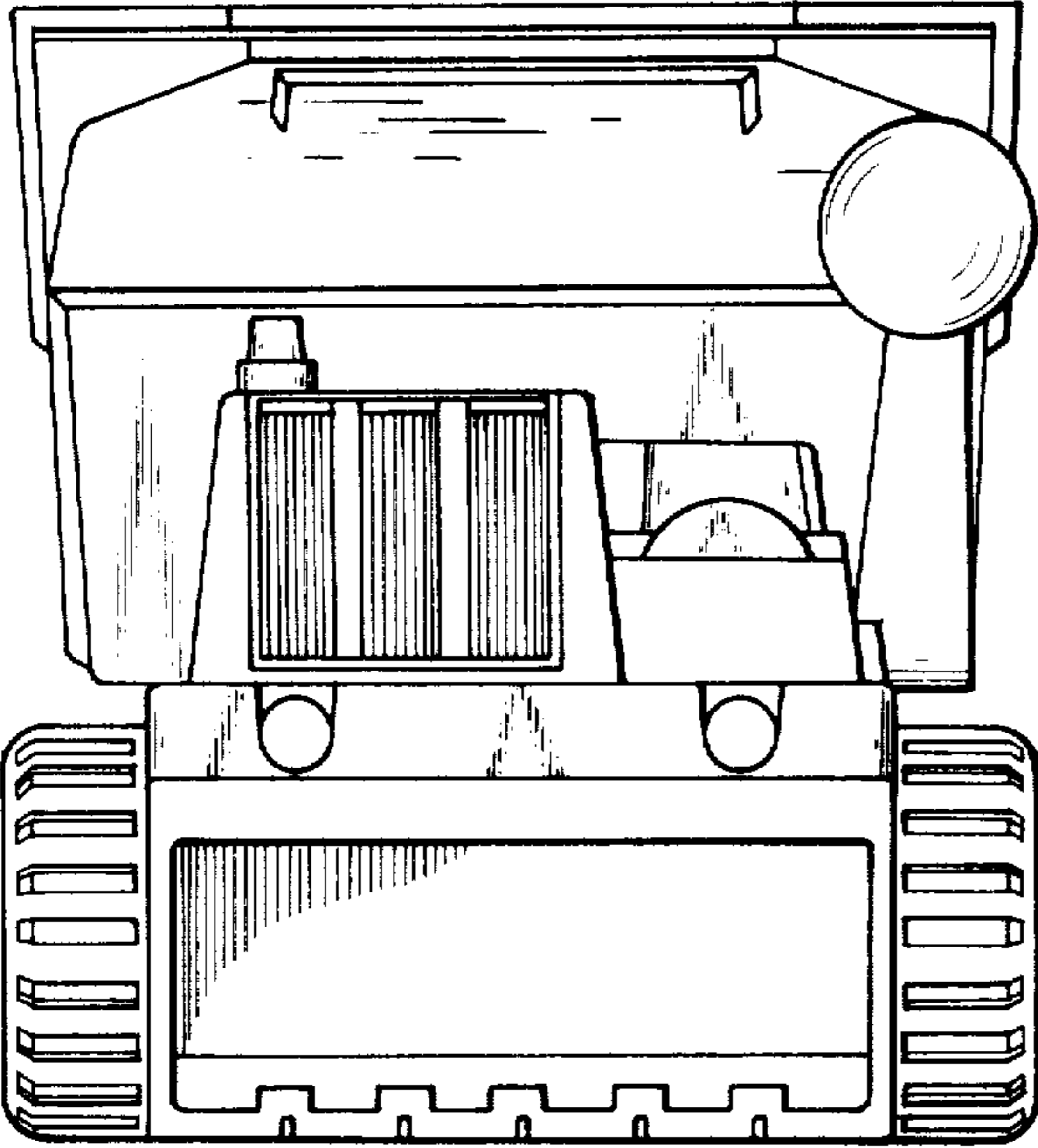

FIG. 3

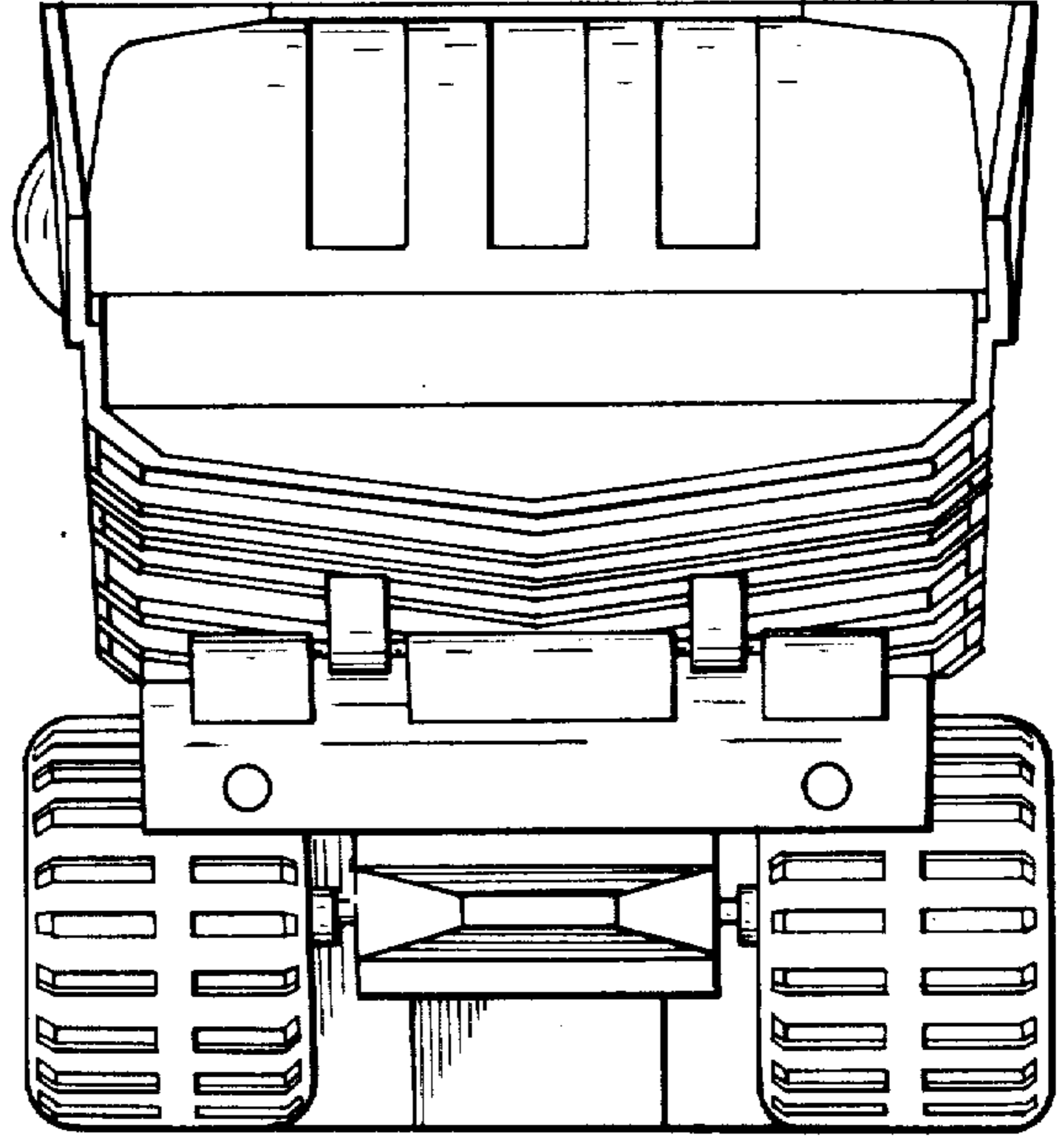

FIG. 4

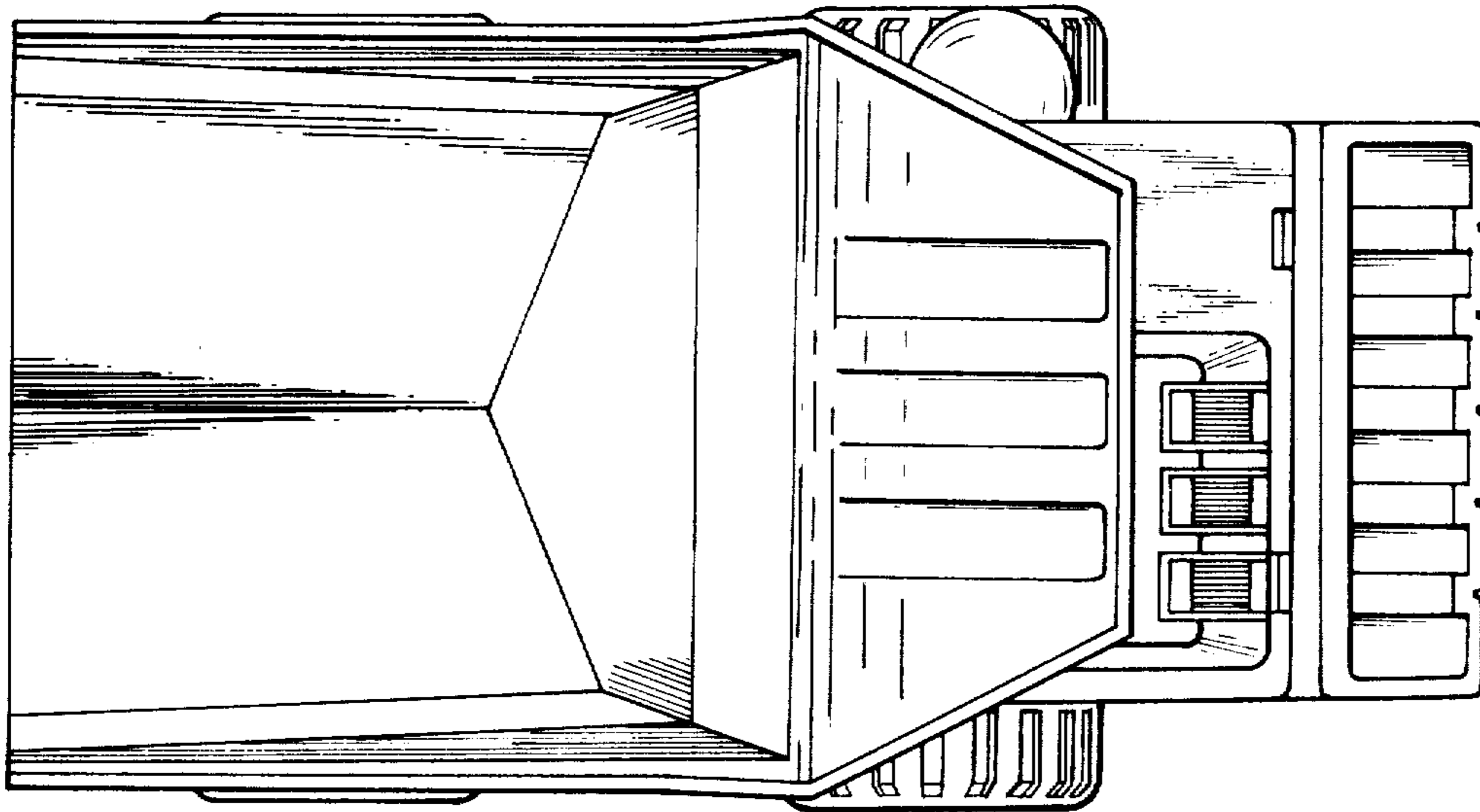

FIG. 5