

[54] **AUTOMOTIVE VEHICLE BODY**
 [76] Inventor: **Guillermo Viniegra**, Ezequiel Chavez No. 52, Col. Vista Bella, Edo. de Mexico, Mexico
 [**] Term: **14 Years**
 [21] Appl. No.: **601,003**
 [22] Filed: **Aug. 1, 1975**
 [51] Int. Cl. **D12-08**
 [52] U.S. Cl. **D12/86**
 [58] Field of Search **D12/86, 91, 92; D34/15 AJ; 296/28 R, 1 R, 15, 31 P; 180/89 R, 89 A**

Complete Encyclopedia of Motorcars, 1885-1968, Rec'd. Apr. 28, 1969, p. 194, 1911 Duryea, Electa 12HP Motor Buggy, Center Left Side of page.
 The Complete Encyclopedia of Motorcars, 1885-1968, Rec'd. Apr. 28, 1969, p. 570, 1906 Tudhope-McIntyre Motor Buggy, Top Left Side of page.

Primary Examiner—Susie J. Mercer
Assistant Examiner—James M. Gandy
Attorney, Agent, or Firm—Leonard J. Robbins

[57] **CLAIM**

The ornamental design for an automotive vehicle body, as shown.

DESCRIPTION

[56] **References Cited**
OTHER PUBLICATIONS
 Merry Old Mobiles on Parade, Oct. 1951, p. 65, the "Michigan", bottom of page.
 Treasury of Foreign Cars Old & New, Rec'd. Apr. 2, 1958, p. 11, Fiat, bottom of page.

FIG. 1, is a top plan view of the automotive vehicle body.
 FIG. 2, is a side elevational view thereof, the opposite side being a mirror image of the side shown herein.
 FIG. 3, is a rear elevational view thereof.
 FIG. 4, is a front elevational view thereof.

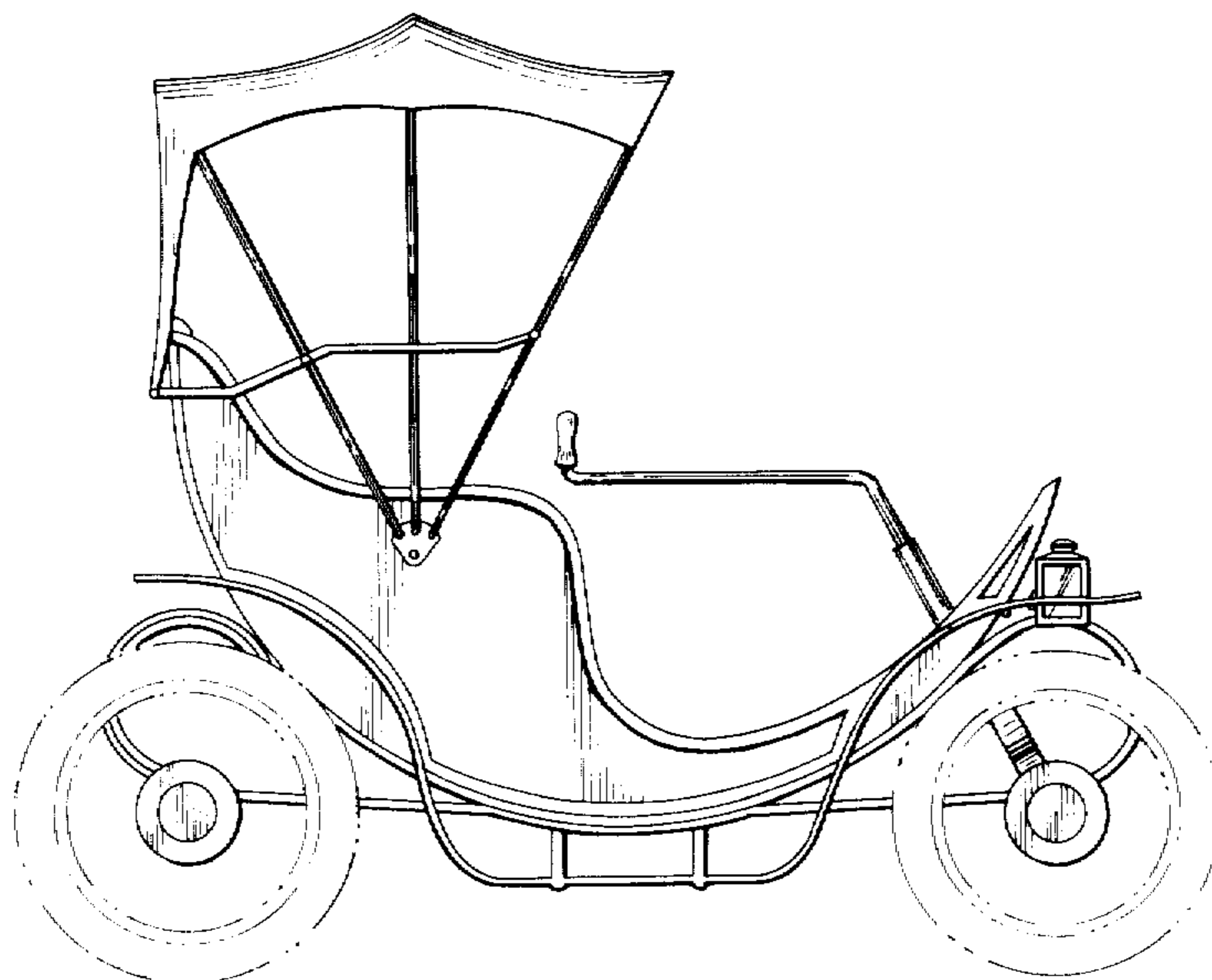
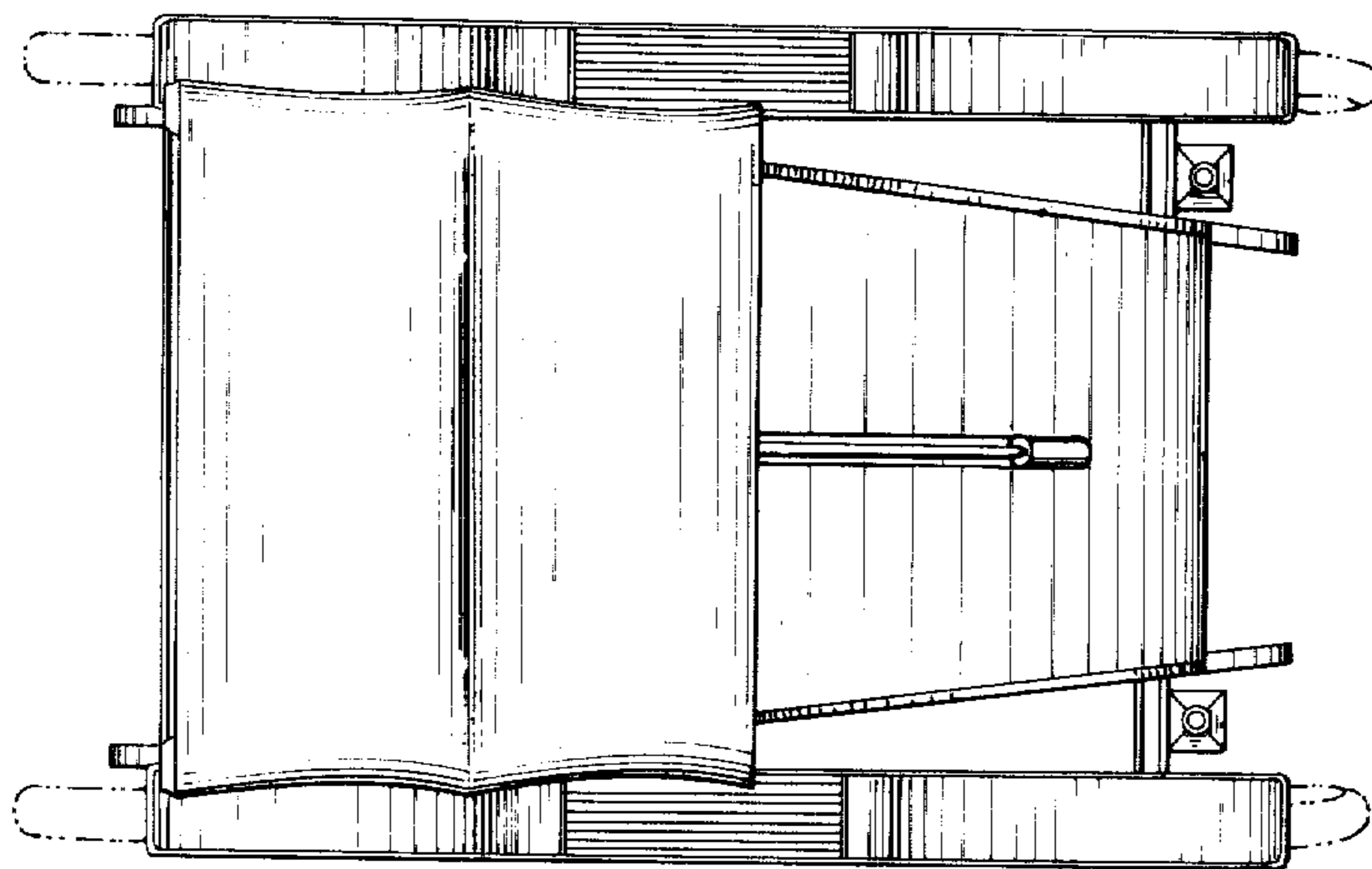

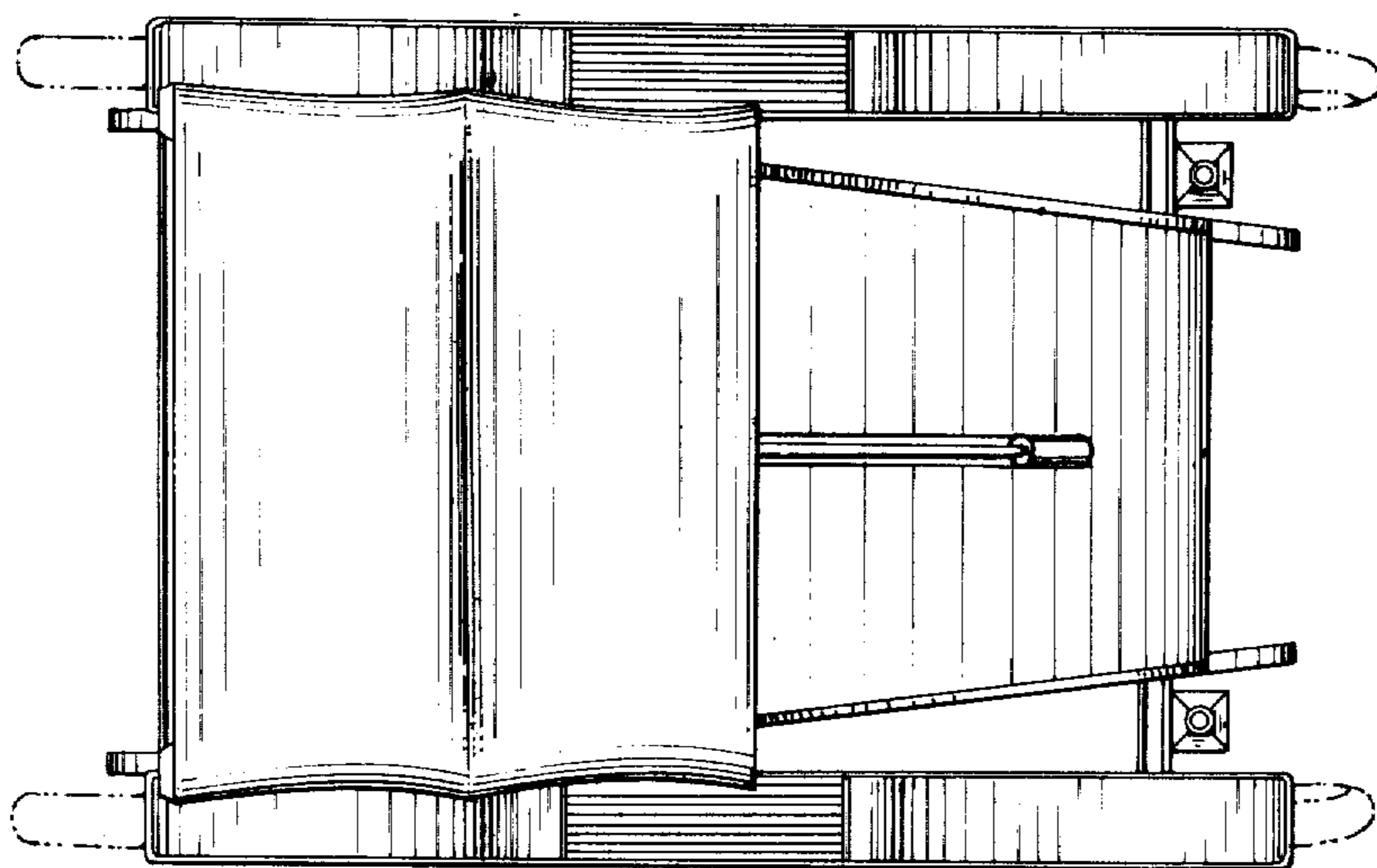

FIG. 1

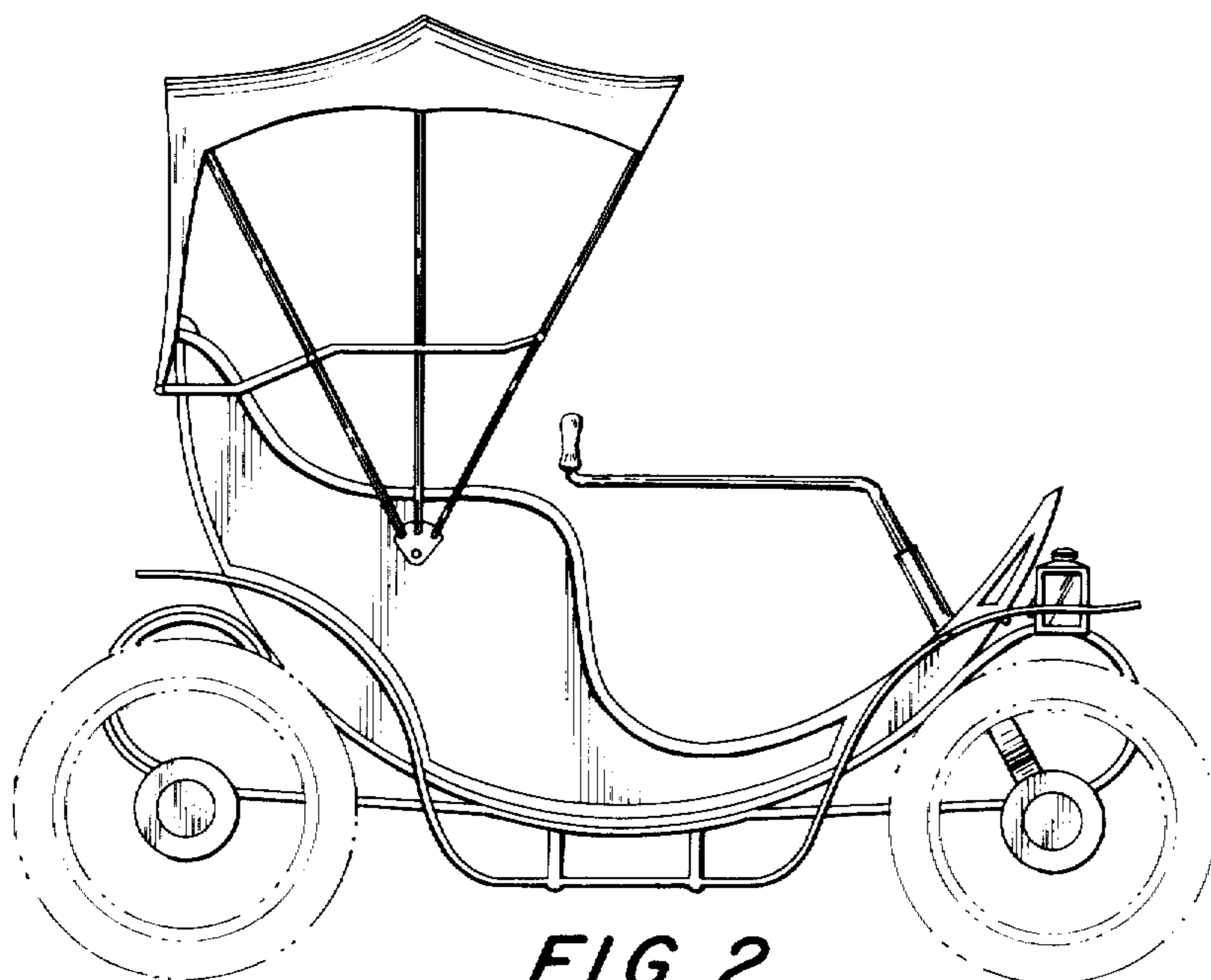

FIG. 2

