



US0D1120141S

(12) **United States Design Patent** (10) **Patent No.:** **US D1,120,141 S**
Hagler et al. (45) **Date of Patent:** **** Mar. 24, 2026**

(54) **MODEL VEHICLE BODY**

(71) Applicant: **TRAXXAS, L.P.**, McKinney, TX (US)
(72) Inventors: **Skylar Hagler**, Anna, TX (US); **Jaime Felix Barajas**, Dallas, TX (US); **Otto Karl Allmendinger**, Rowlett, TX (US); **Adam Cole Ewing**, McKinney, TX (US); **Kent Poteet**, Lucas, TX (US)
(73) Assignee: **TRAXXAS, L.P.**, McKinney, TX (US)

(**) Term: **15 Years**

(21) Appl. No.: **29/936,706**

(22) Filed: **Apr. 10, 2024**

(51) **LOC (15) Cl.** **21-01**

(52) **U.S. Cl.**
USPC **D21/562**

(58) **Field of Classification Search**
USPC D21/424, 433, 434, 483, 495, 533, 548,
D21/549, 550, 552, 560, 562, 581, 833
CPC A63H 17/262; A63H 17/26; A63H 19/15
See application file for complete search history.

(56) **References Cited**

U.S. PATENT DOCUMENTS

D567,301 S *	4/2008	Idiot	D21/549
D797,205 S *	9/2017	Mortier, Jr.	D21/549
D870,824 S *	12/2019	Barajas	D21/562
D879,212 S *	3/2020	Barajas	D21/562
D935,531 S *	11/2021	Barajas	D21/548
D1,073,820 S *	5/2025	Ewing	D21/548

FOREIGN PATENT DOCUMENTS

EP	15075069	* 10/2024
GB	6395768	* 10/2024

OTHER PUBLICATIONS

Competition Ready | @Traxxas Slash Modified, as shown in www.YouTube.com, Jun. 12, 2024. (Year: 2024).*
Traxxas Slash® Modified 1/10 Dirt Oval ProGraphix® Body (Clear), Part# TRA10411X, as shown in www.amainhobbies.com, Feb. 11, 2025. (Year: 2025).*
McAllister Racing Dagger SC Modified Oval Body (Clear), Part#: MCA800, as shown in www.amainhobbies.com, Jan. 14, 2025. (Year: 2025).*

* cited by examiner

Primary Examiner — George J Ulsh

Assistant Examiner — Gregory G Mclemore

(74) *Attorney, Agent, or Firm* — Daryl R. Wright; Greg Carr

(57) **CLAIM**

The ornamental design for a model vehicle body as shown and described.

DESCRIPTION

FIG. 1 is an upper, left, front perspective view of a model vehicle body showing our new design;
FIG. 2 is an upper, right, rear perspective view thereof;
FIG. 3 is a lower, right, front perspective view thereof;
FIG. 4 is a lower, left, rear perspective view thereof;
FIG. 5 is a front elevation view thereof;
FIG. 6 is a rear elevation view thereof;
FIG. 7 is an upper plan view thereof;
FIG. 8 is a lower plan view thereof;
FIG. 9 is a right-side elevation view thereof; and,
FIG. 10 is a left-side elevation view of the model vehicle body.

1 Claim, 9 Drawing Sheets

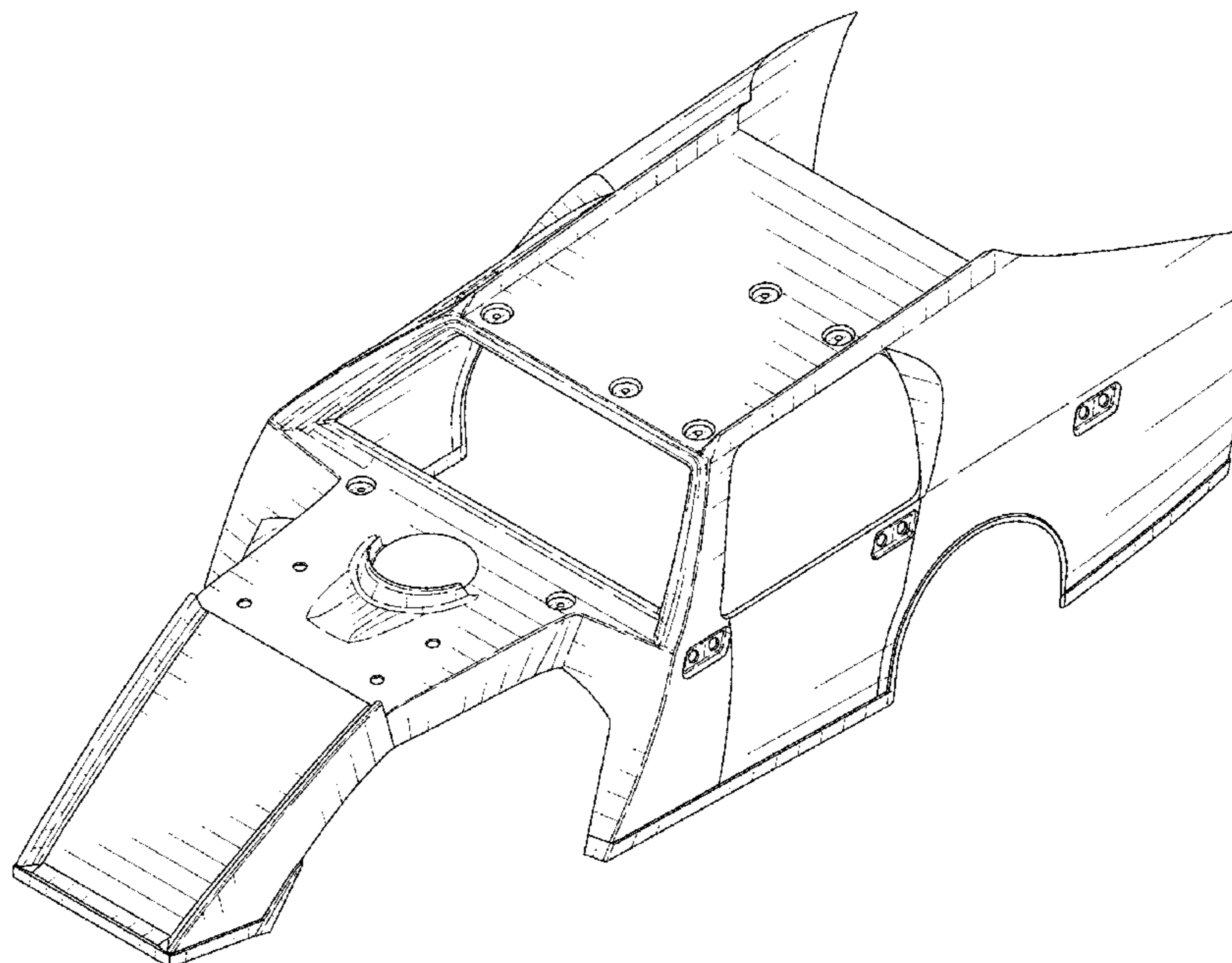

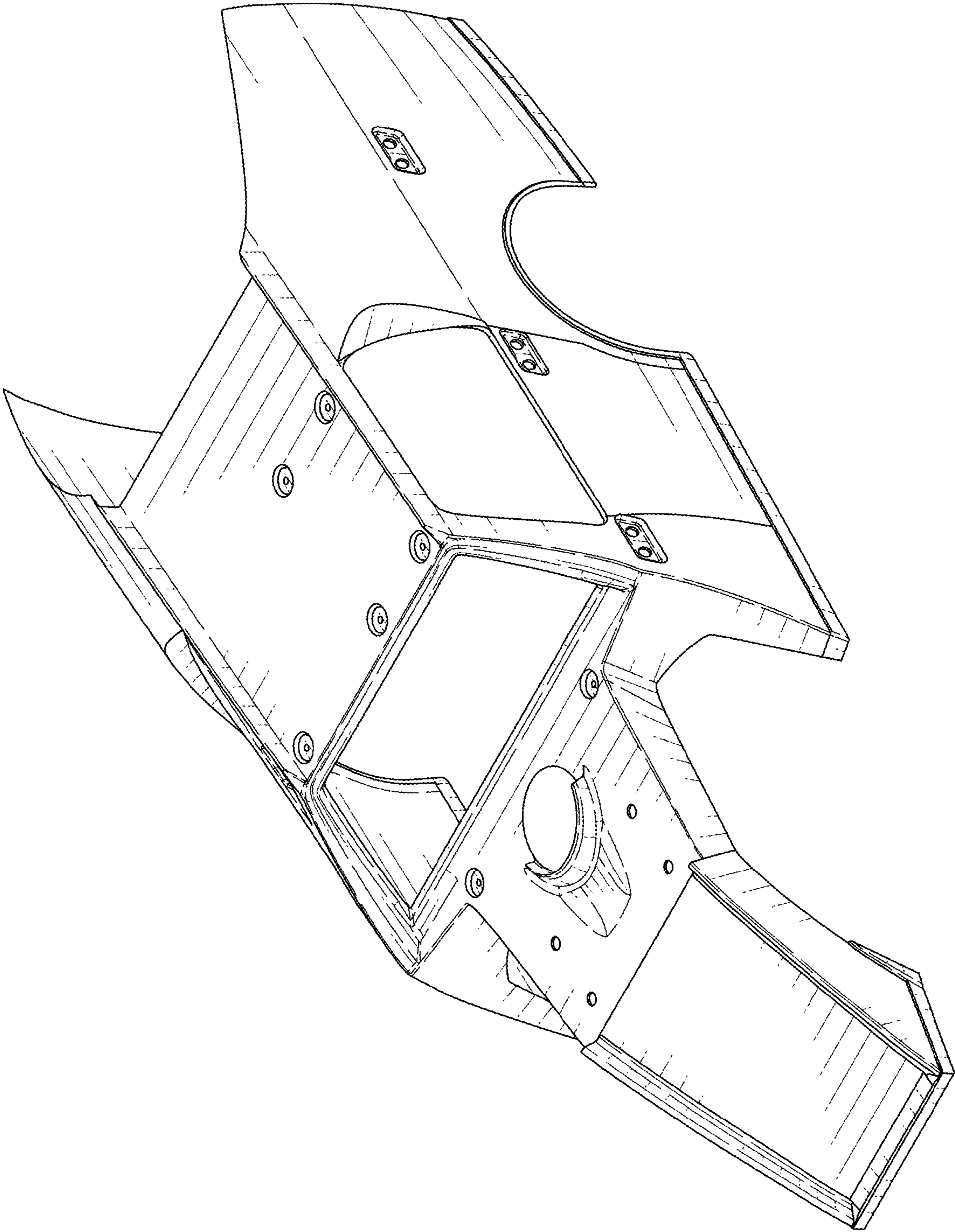

FIG. 1

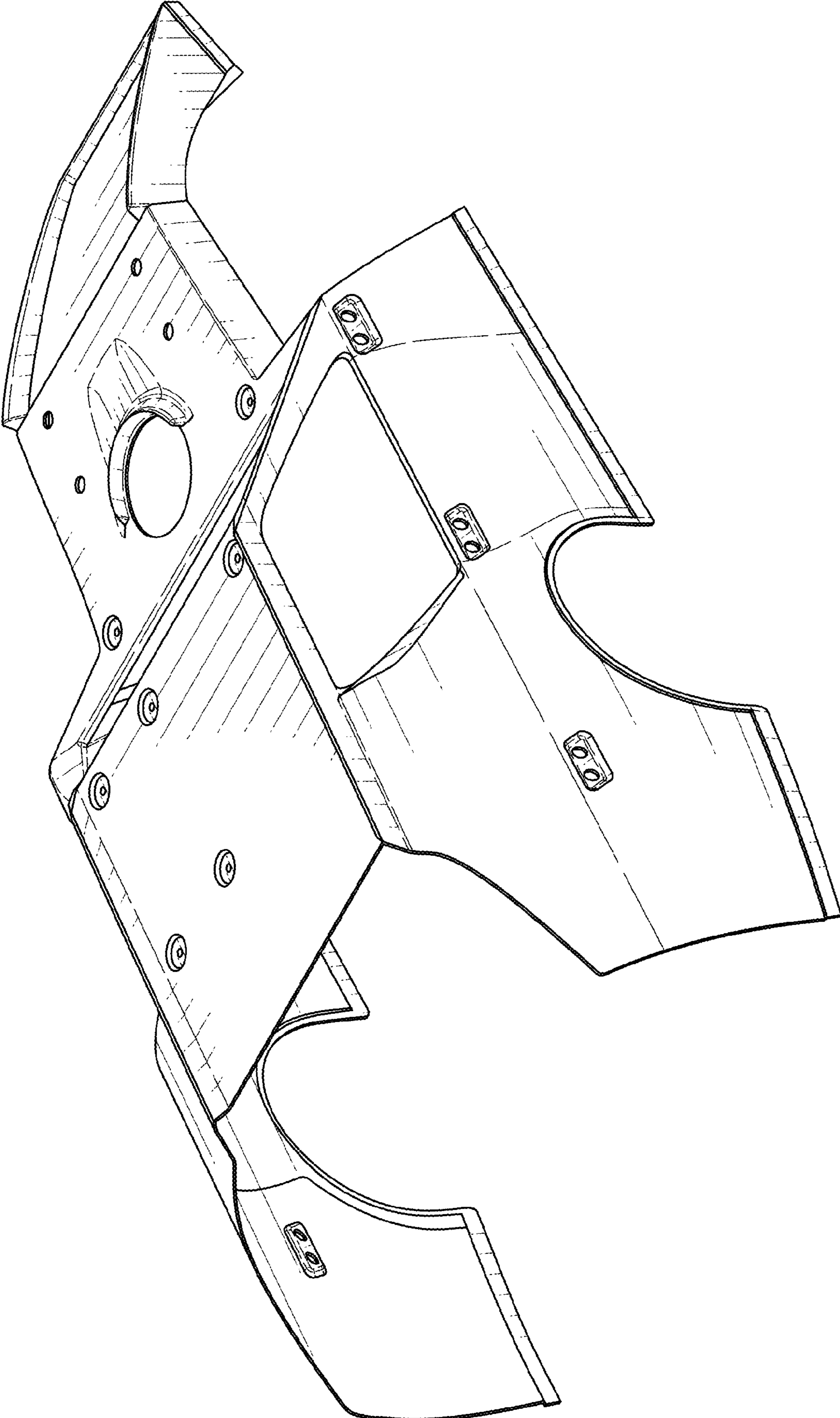

FIG. 2

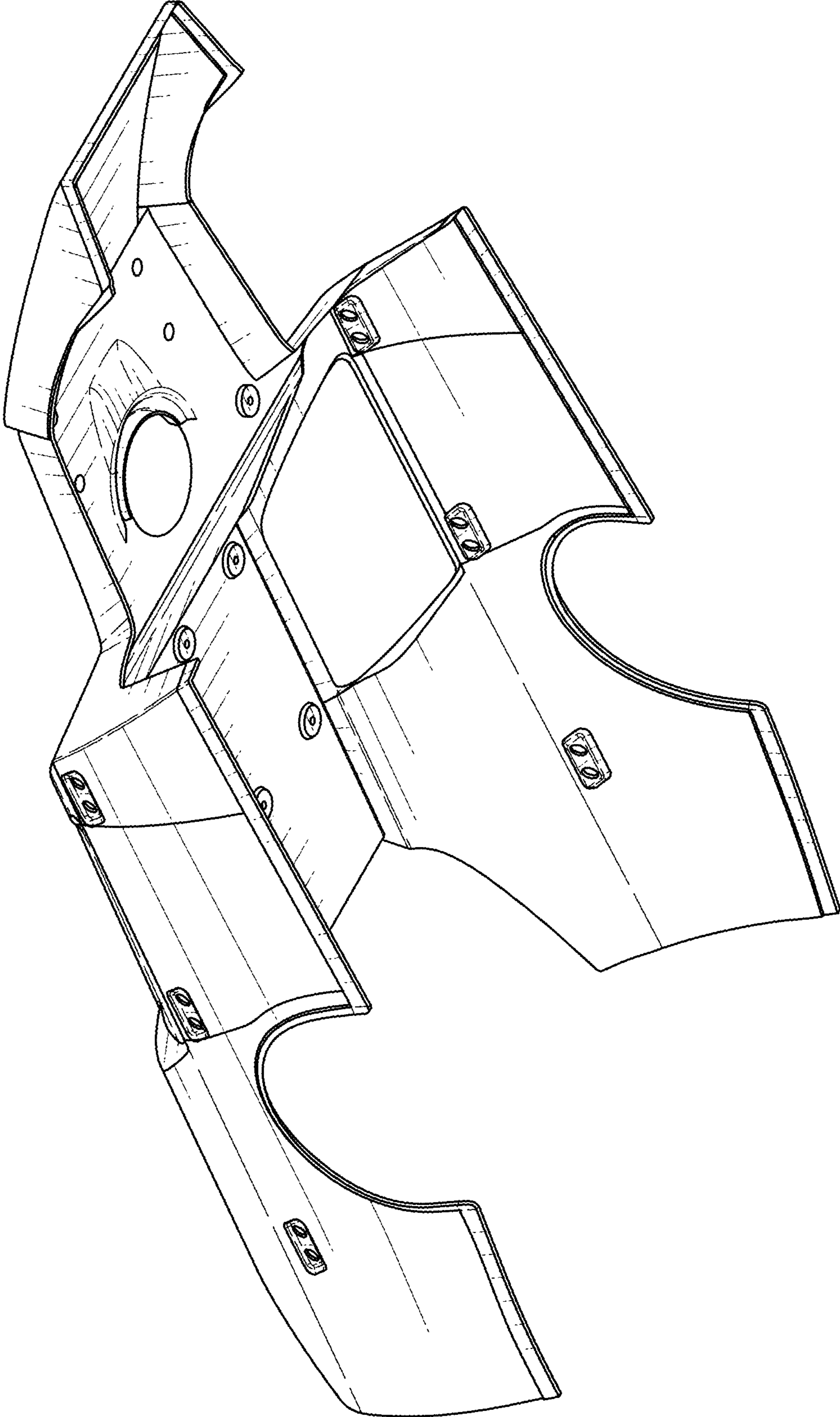

FIG. 3

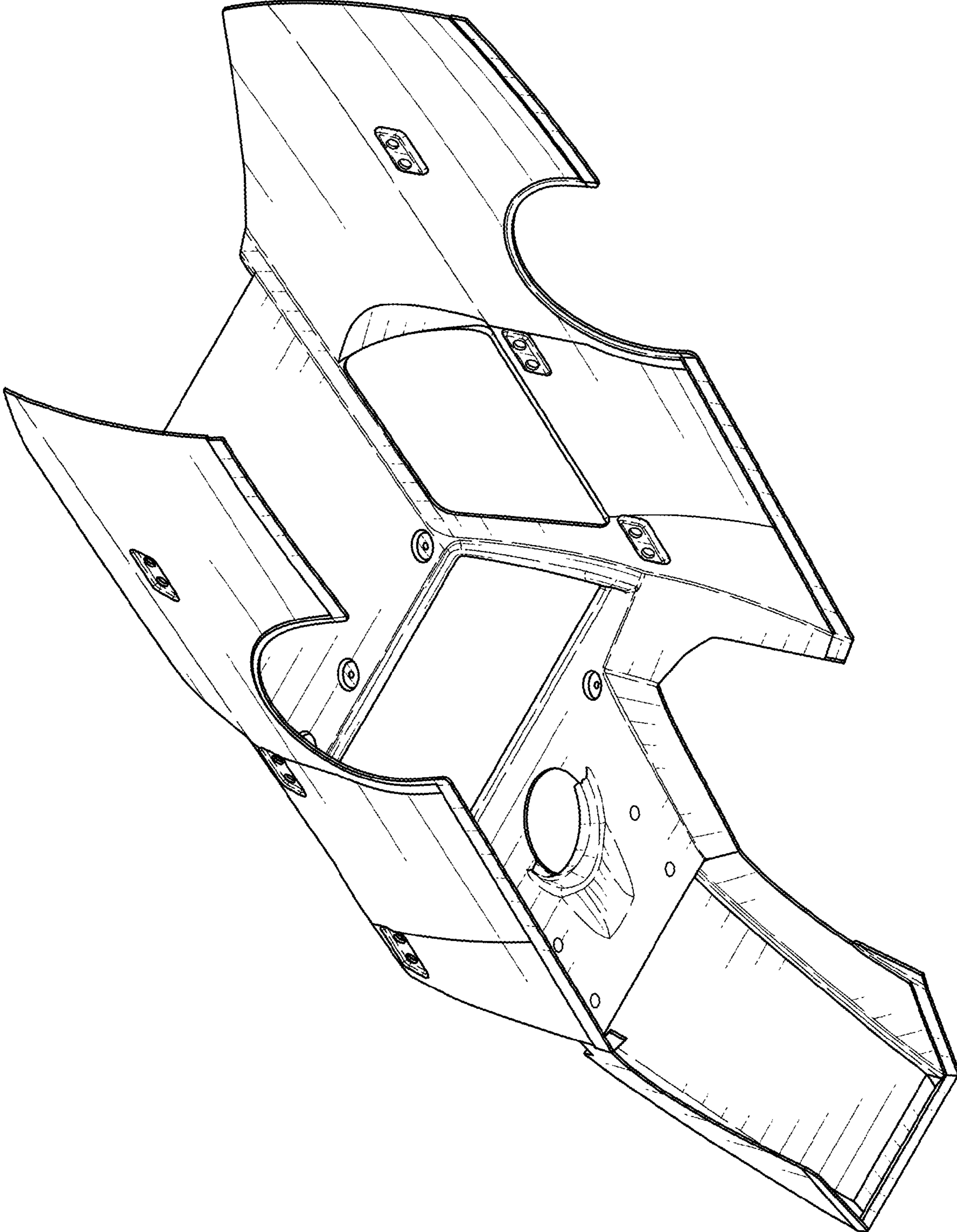

FIG. 4

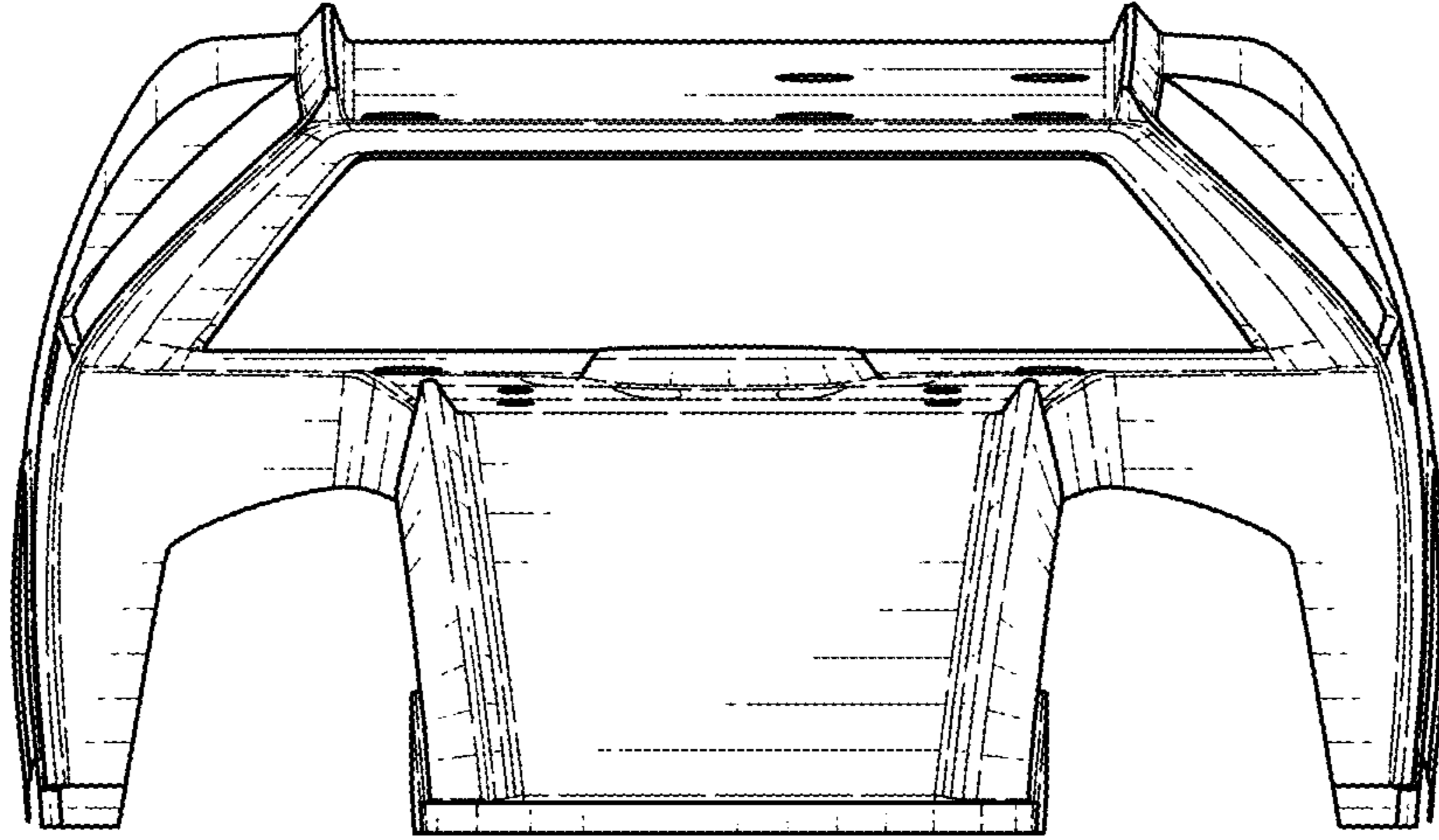

FIG. 5

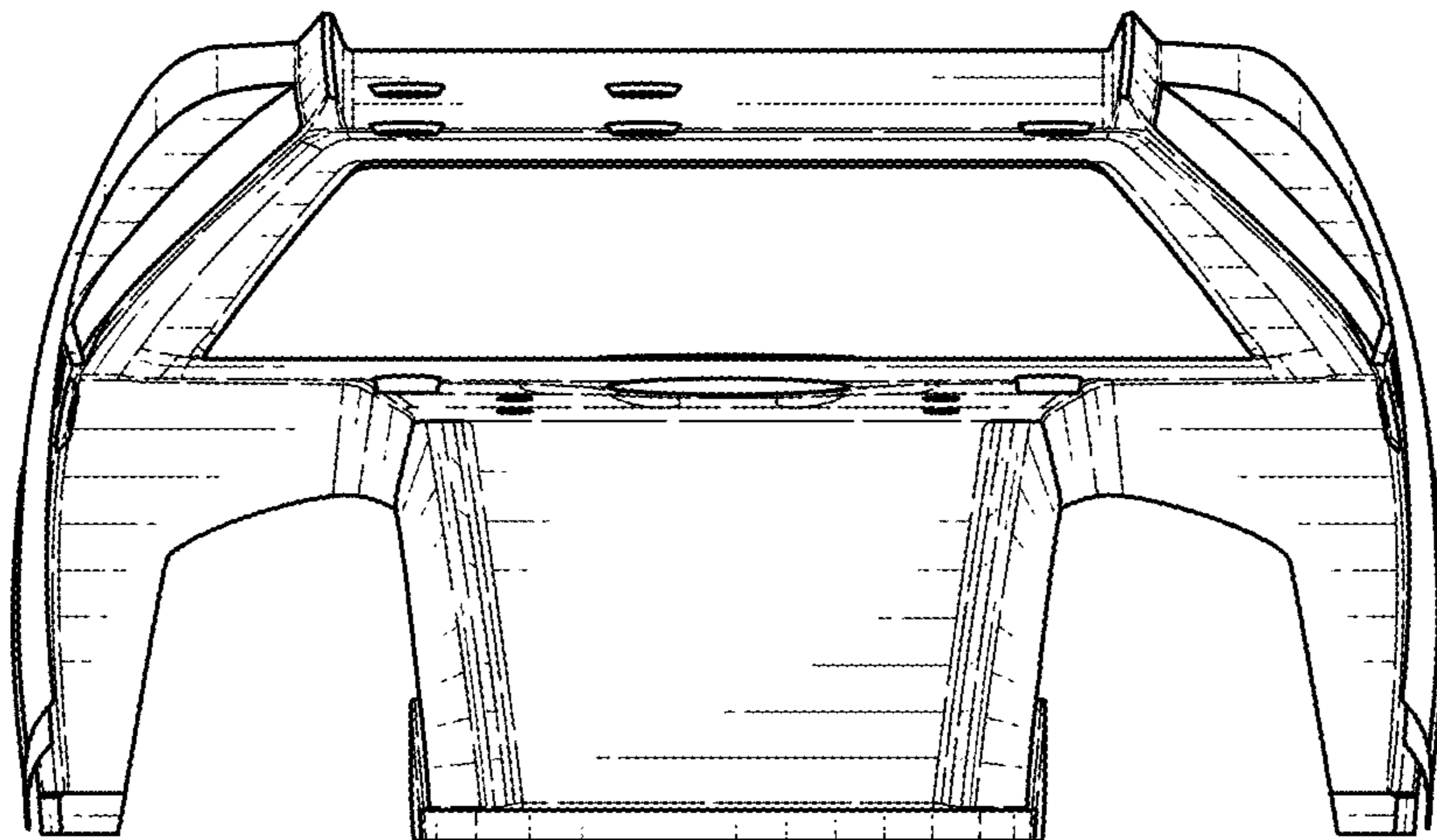

FIG. 6

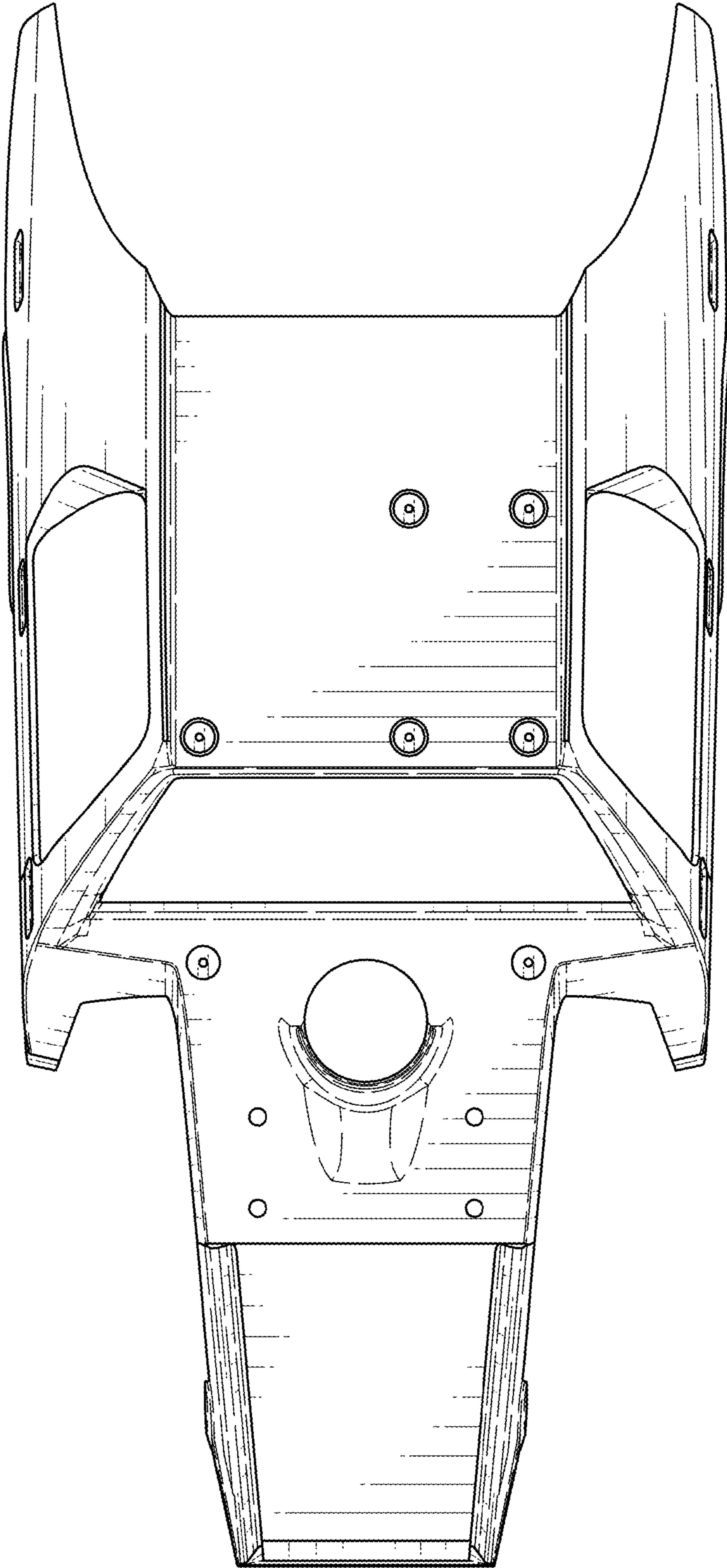

FIG. 7

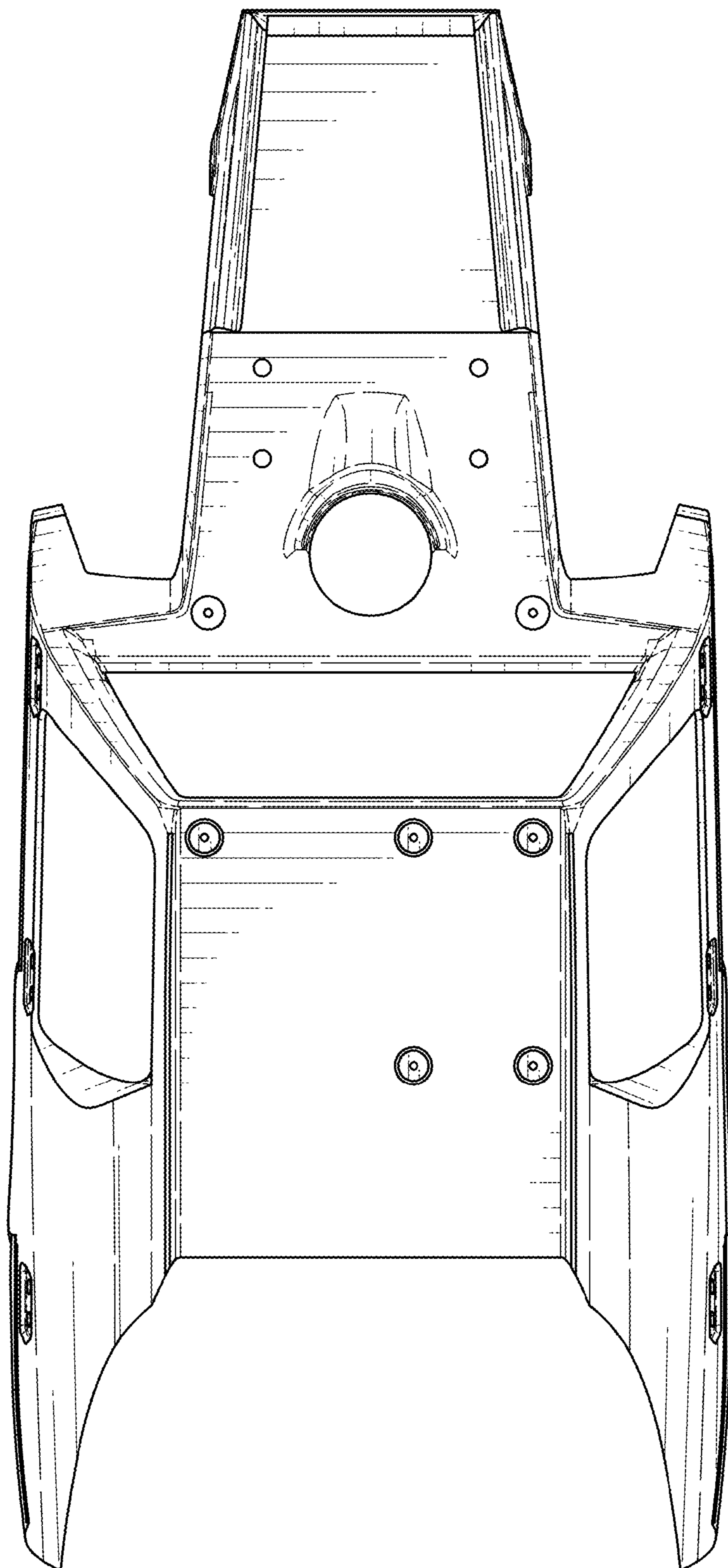

FIG. 8

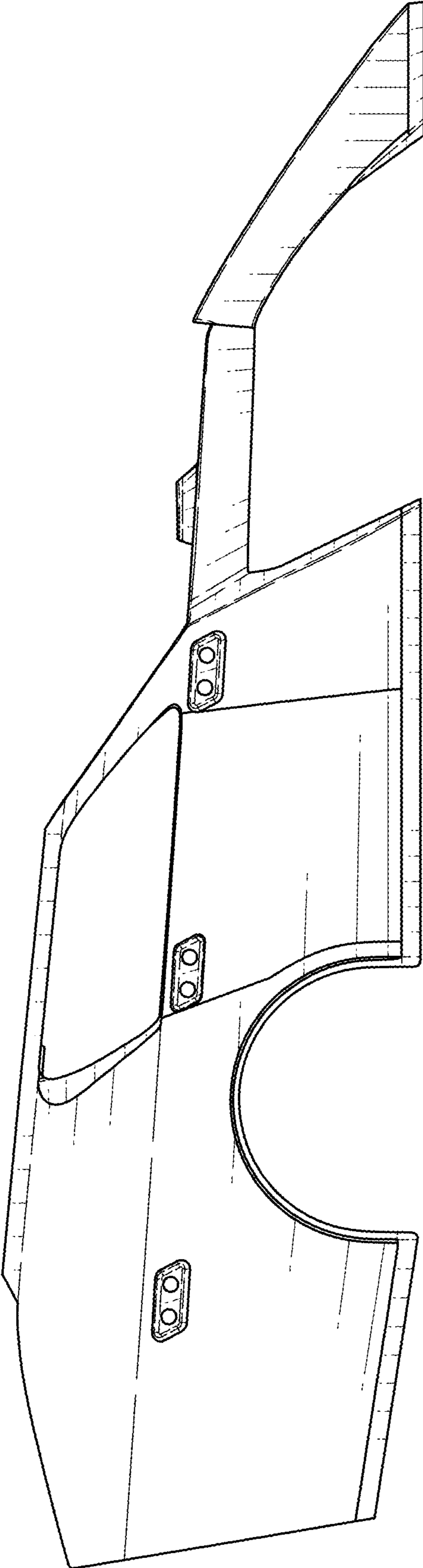

FIG. 9

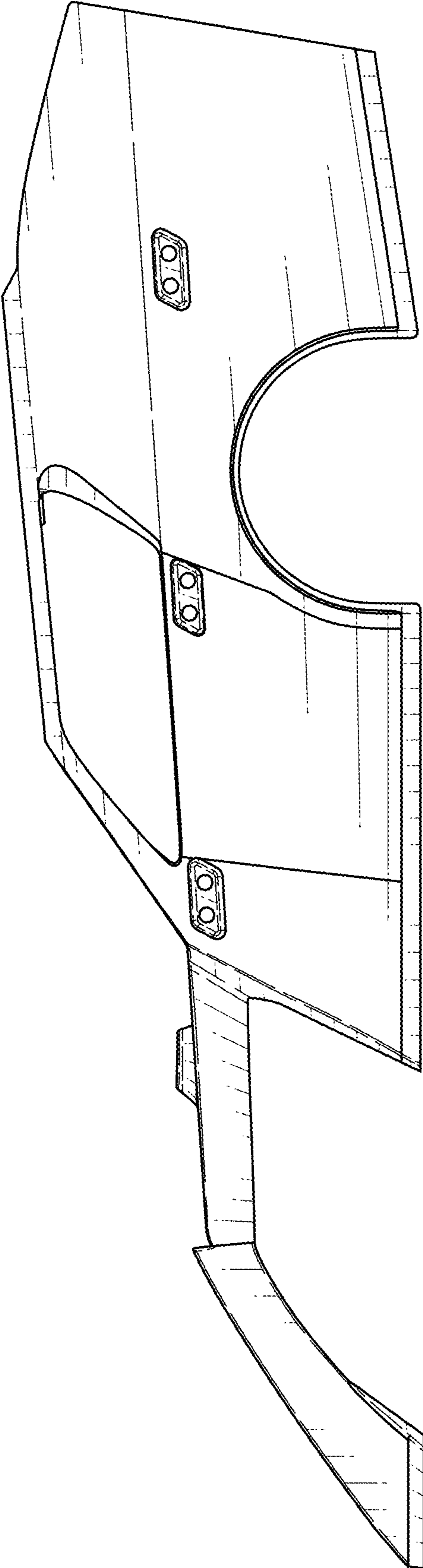

FIG. 10