



US0D1074845S

(12) **United States Design Patent** (10) **Patent No.:** **US D1,074,845 S**
Hagler et al. (45) **Date of Patent:** **** May 13, 2025**

(54) **MODEL VEHICLE ROOF SKID**

FOREIGN PATENT DOCUMENTS

(71) Applicant: **TRAXXAS, L.P.**, McKinney, TX (US)

CA 2672116 A1 4/2006
CN 306105154 10/2020

(72) Inventors: **Skylar Hagler**, Anna, TX (US); **Jory Sprowl**, Howe, TX (US); **Otto Karl Allmendinger**, Rowlett, TX (US); **Adam Cole Ewing**, McKinney, TX (US); **Kent Poteet**, Lucas, TX (US)

(Continued)

(73) Assignee: **TRAXXAS, L.P.**, McKinney, TX (US)

OTHER PUBLICATIONS

(**) Term: **15 Years**

Ford Bronco Hard Top Removal With Roof Rails Our Bronco Life, as shown in www.youtube.com, Feb. 2, 2022. (Year: 2022).

(21) Appl. No.: **29/908,123**

(Continued)

(22) Filed: **Jan. 11, 2024**

Primary Examiner — Cynthia M. Chin

(51) **LOC (15) Cl.** **21-01**

(74) *Attorney, Agent, or Firm* — Daryl R. Wright; Greg Carr

(52) **U.S. Cl.**

USPC **D21/561**; D12/414

(58) **Field of Classification Search**

USPC D21/424, 431, 433, 434, 495, 533, 537, D21/548, 552, 561, 562; D12/414, 196
CPC A63H 17/00; A63H 17/002; A63H 17/05; A63H 17/12

See application file for complete search history.

(57) **CLAIM**

The ornamental design for a model vehicle roof skid as shown and described.

(56) **References Cited**

U.S. PATENT DOCUMENTS

D182,705 S	5/1958	Binding
D212,186 S	9/1968	Bott
D219,463 S	12/1970	Diamond
3,829,117 A	8/1974	Park
D239,618 S	4/1976	Duer et al.
D264,203 S	5/1982	Bott
D306,569 S	3/1990	Walz et al.
D306,570 S	3/1990	Lomonaco
D317,336 S	6/1991	Tsuchiya
D322,770 S	12/1991	Helms
D332,978 S	2/1993	Tsuchiya
D332,979 S	2/1993	Tsuchiya
D334,007 S	3/1993	Cucheran et al.

(Continued)

DESCRIPTION

FIG. 1 is an upper, left, front perspective view of a model vehicle roof skid showing our new design; FIG. 2 is an upper, right, rear perspective view thereof; FIG. 3 is a lower, right, front perspective view thereof; FIG. 4 is a lower, left, rear perspective view thereof; FIG. 5 is a front elevation view thereof; FIG. 6 is a rear elevation view thereof; FIG. 7 is an upper plan view thereof; FIG. 8 is a lower plan view thereof; FIG. 9 is a right-side elevation view thereof; and, FIG. 10 is a left-side elevation view of the model vehicle roof skid.

In the drawings, the broken lines illustrate portions of the model vehicle roof skid that form no part of the claimed design. Only the left-side model vehicle roof skid is shown. The right-side model vehicle roof skid is a mirror image of the shown model vehicle roof skid.

1 Claim, 7 Drawing Sheets

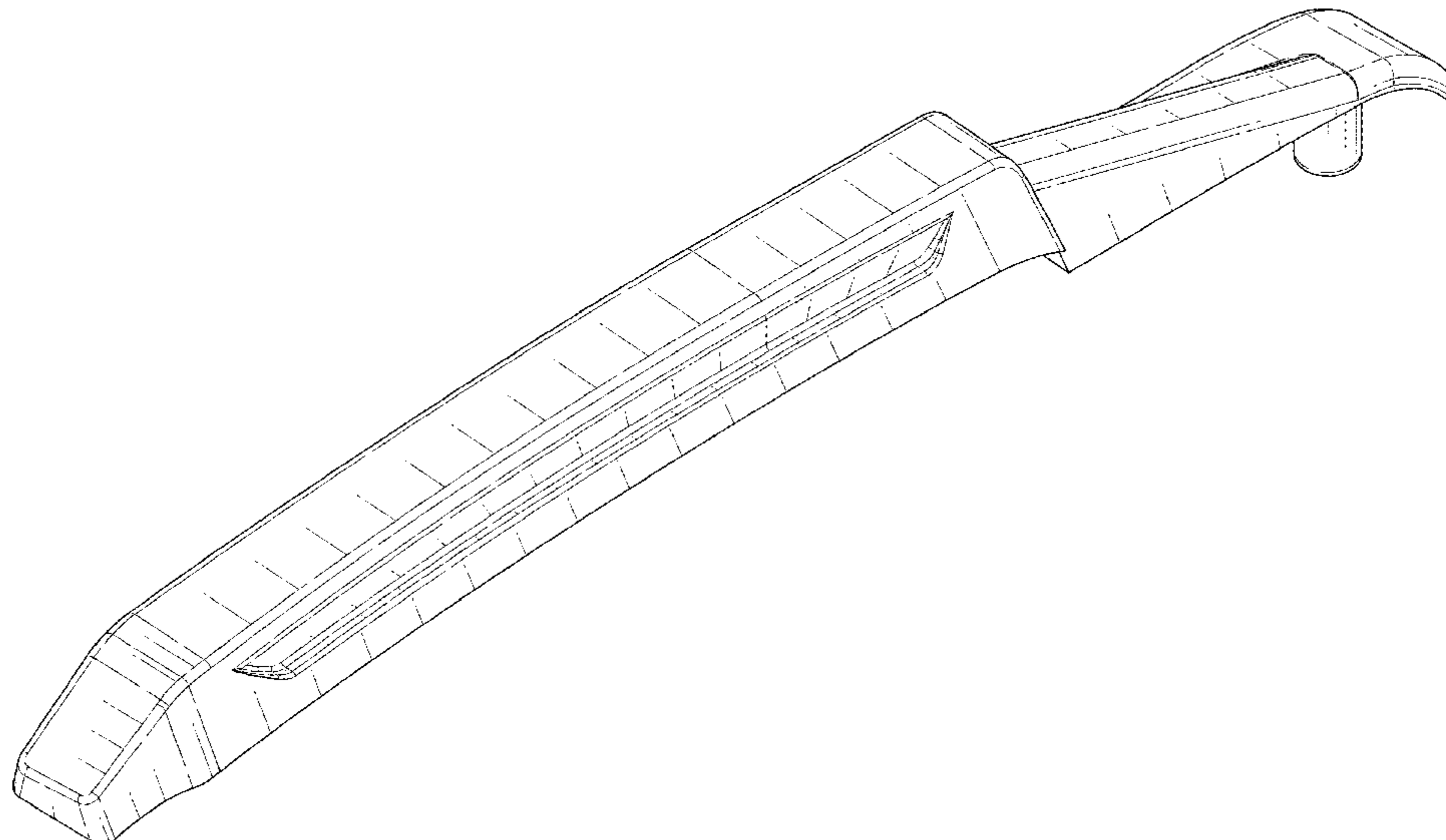

(56)

References Cited

U.S. PATENT DOCUMENTS

D334,373 S 3/1993 Cucheran
 D348,911 S 7/1994 Herrick et al.
 D381,311 S 7/1997 Prasatek et al.
 D411,263 S 6/1999 Korsholm
 D434,364 S 11/2000 Bauer et al.
 6,561,397 B1 5/2003 Bauer et al.
 D477,257 S 7/2003 Delgado
 D487,041 S 2/2004 Schlachter
 D493,848 S 8/2004 Dunst
 D503,658 S 4/2005 Lu
 D513,223 S 12/2005 Saito et al.
 D521,899 S 5/2006 Walden
 D523,775 S 6/2006 Walden
 D523,776 S 6/2006 Walden
 D534,593 S 1/2007 Yuen
 D546,756 S 7/2007 Marquez
 D554,574 S 11/2007 Hanson et al.
 D556,648 S 12/2007 Nelson et al.
 D564,410 S 3/2008 Lepage
 D564,433 S 3/2008 Sato
 D567,886 S 4/2008 Lampert et al.
 D586,695 S 2/2009 Burns
 D586,696 S 2/2009 Burns
 D593,616 S 6/2009 Asai
 D627,704 S 11/2010 Bucher et al.
 D639,207 S 6/2011 Danisi
 D642,090 S 7/2011 Karacabey et al.
 D642,091 S 7/2011 Karacabey et al.
 D642,960 S 8/2011 Berrier
 D647,002 S 10/2011 Mullen
 D651,133 S 12/2011 Liebl
 D655,236 S 3/2012 Sanschagrín
 D655,668 S 3/2012 Levorato et al.
 D678,173 S 3/2013 McIntire
 D681,542 S 5/2013 Oliver
 D686,136 S 7/2013 Galley
 D690,256 S 9/2013 Ewringmann
 D690,639 S 10/2013 Messale
 D691,523 S 10/2013 Waugh et al.
 D695,206 S 12/2013 Eriksson
 D728,450 S 5/2015 Yen
 D730,806 S 6/2015 Lim
 D739,321 S 9/2015 Blanski et al.
 D740,719 S 10/2015 Schanz et al.
 9,150,159 B1 10/2015 Meszaros et al.
 D758,281 S 6/2016 Galloway
 D761,713 S 7/2016 Hensley
 D764,972 S 8/2016 Gonzalez
 D766,157 S 9/2016 Reynolds et al.
 D772,783 S 11/2016 Schleef
 9,487,260 B1 11/2016 Seehorn
 D776,601 S 1/2017 McDonald, II et al.
 D777,619 S 1/2017 Barajas et al.
 D778,784 S 2/2017 Hirooka
 D779,392 S 2/2017 Hare
 D781,207 S 3/2017 Johnson
 D783,502 S 4/2017 Hensley
 D783,503 S 4/2017 Hensley
 D783,726 S 4/2017 Williams et al.
 D793,328 S 8/2017 Bridges
 D803,141 S 11/2017 Peat
 D810,148 S 2/2018 Loew et al.
 D815,581 S 4/2018 Anderson et al.
 D816,009 S 4/2018 Reynolds et al.
 D816,011 S 4/2018 Garcia
 D820,736 S 6/2018 Vaarsi
 D822,126 S 7/2018 Allmendinger et al.
 D826,831 S 8/2018 Eck et al.
 D827,054 S 8/2018 Ewing et al.
 D828,796 S 9/2018 Allmendinger et al.
 D829,831 S 10/2018 Redlin et al.
 D833,366 S 11/2018 Dowdey
 D833,957 S 11/2018 DiCanzio
 D836,501 S 12/2018 Mori
 D837,307 S 1/2019 Jin

D839,363 S 1/2019 Ewing et al.
 D847,724 S 5/2019 Sprowl et al.
 D856,262 S 8/2019 Marankie
 D856,432 S 8/2019 Ewing et al.
 D856,434 S 8/2019 Wood
 D856,435 S 8/2019 Wood
 D857,807 S 8/2019 Wood
 D859,283 S 9/2019 Adler et al.
 D862,610 S 10/2019 Barajas et al.
 D863,200 S 10/2019 Kuschmeader et al.
 D864,310 S 10/2019 Jens Christensen et al.
 D864,840 S 10/2019 Wood
 D865,079 S 10/2019 Ewing
 D866,448 S 11/2019 Ash
 D867,232 S 11/2019 Izard
 D867,474 S 11/2019 Ewing et al.
 D867,475 S 11/2019 Ewing et al.
 D867,476 S 11/2019 Wood et al.
 D870,615 S 12/2019 Wood
 D876,555 S 2/2020 Barajas et al.
 D877,014 S 3/2020 Harriton et al.
 D885,302 S 5/2020 Sprowl et al.
 D891,356 S 7/2020 Sprowl et al.
 D894,809 S 9/2020 Chi
 D897,930 S 10/2020 MacIndoe
 D899,989 S 10/2020 Chi
 D900,007 S 10/2020 Zhang et al.
 10,814,917 B2 10/2020 Lorenz et al.
 D902,817 S 11/2020 Choi et al.
 D902,836 S 11/2020 Hornsby et al.
 D906,225 S 12/2020 Eriksson et al.
 D920,188 S 5/2021 Choi et al.
 D921,772 S 6/2021 Hagler et al.
 D921,773 S 6/2021 Hagler et al.
 D924,338 S 7/2021 Wood et al.
 D931,385 S 9/2021 Sprowl et al.
 D935,531 S 11/2021 Barajas et al.
 D950,450 S 5/2022 Buller
 D955,323 S 6/2022 Reid et al.
 D960,254 S 8/2022 Ewing et al.
 D960,255 S 8/2022 Ewing et al.
 D962,743 S 9/2022 Adkison
 D986,141 S 5/2023 Alfakhrany et al.
 D986,142 S 5/2023 Alfakhrany et al.
 11,752,945 B2 9/2023 Tertuliani et al.
 D1,014,650 S * 2/2024 Sprowl D21/561
 D1,014,652 S * 2/2024 Christensen D21/561
 D1,020,927 S * 4/2024 Collins D21/562
 D1,044,617 S * 10/2024 Choi D12/163
 D1,046,011 S 10/2024 Ewing et al.
 D1,051,242 S 11/2024 Ewing et al.
 D1,051,243 S 11/2024 Ewing et al.
 2006/0151554 A1 7/2006 Bulski et al.
 2012/0125961 A1 5/2012 Gobart
 2014/0067215 A1 3/2014 Wetterlund et al.
 2017/0106827 A1 4/2017 Barbat et al.
 2017/0120836 A1 5/2017 Calvin
 2019/0375337 A1 12/2019 Gauci
 2021/0179195 A1 6/2021 Kim
 2023/0219010 A1 7/2023 Christensen et al.

FOREIGN PATENT DOCUMENTS

CN 307697908 11/2022
 EM 015009705-0005 2/2023
 EM 015013355-0010 3/2023
 GB 6228970 10/2022
 GB 6258117 2/2023
 GB 6258118 2/2023
 GB 6265723 3/2023
 KR 101355712 B1 1/2014

OTHER PUBLICATIONS

Bronco 4DR 2021-2024 OE Roof Rack, SKU: M2DZ9955100BA, as shown in www.accesories.ford.com, no publication date listed, fits truck years 2021-2024. Date Found Sep. 22, 2024. (Year: 2024). RC4WD CChand Roof Rails for Traxxas TRX-4 2021 Bronco

(56)

References Cited

OTHER PUBLICATIONS

(Style B), Part# RC4VVC1236, as shown in www.hobbytown.com, Apr. 21, 2022. (Year: 2022).

Traxxas TRX-4M Ford Bronco Complete Unassembled Body (Unpainted), Part # TRA9711, as shown in www.hobbytown.com, Aug. 19, 2024. (Year: 2024).

E-Revo Data, Traxxas.com, [online], [site visited Jun. 3, 2020]. <URL: <https://traxxas.com/products/landing/e-revo/>> (Year: 2020).

Maxx Data, Traxxas.com, [online], [site visited Jun. 3, 2020]. <URL: <https://traxxas.com/products/landing/maxx/>> (Year: 2020).

Rustler 4x4 VXL Data, Traxxas.com, [online], [site visited Jun. 3, 2020]. <URL: <https://traxxas.com/products/landing/rustler-4x4-vxl/>> (Year: 2020).

Polaris Molded UTV Roof 1/Cargo Tray (16-20 Ranger 1000 & 1000XP / 13-20 Ranger 900XP), RoughCountry.com, [online], [site visited Jun. 3, 2020]. <URL: <https://www.roughcountry.com/polaris-ranger-molded-utv-roof-79313202.html>> (Year: 2020).

Traxxas Roof Skid Plate for E-Revo, 8617, Tin-Eye Date Nov. 20, 2019 [Online]. [Site visited Oct. 21, 2020] Available from Internet, URL: <https://www.rchobbyexplosion.com/Traxxas_Roof_Skid_Plate_Next_Gen_E_Revo_p/tra8617.htm?gclid=EAlalQobChMI5PiisqHG7AIVJYFaBR00gwhOEAQYAyABEgJVWfD-BwE> (Year: 2019).

Pre-Cut Brute Clear Body, Earliest Available Date Oct. 21, 2020 [Online]. [Site Visited Oct. 21, 2020] Available from Internet, URL: <<https://www.prolinerracing.com/bodies/pre-cut-brute-clear-body-e-revo2.asp>> (Year: 2020).

Traxxas 8917 Skid Plate, Roof (Body) (Black) / 3x10mm Cs (4), Earliest Available Date Sep. 8, 2020 [Online]. [Site Visited Oct. 21, 2020] Available from Internet, URL: <https://www.amazon.com/Traxxas-8917-Plate-Black-3x10mm/dp/B081LMQQJ/ref=sr_1_1?dchild=1&keywords=B081LMQQJ&qid=1603998167&sr=8-1> (Year: 2020).

Traxxas Sledge Body Roof Skid Pads (Blue), as shown in www.hobbytown.com, Jul. 21, 2022. Part # TRA9510X. (Year: 2022).

Traxxas 9017 Skid Plate, roof (Body) (Black) (Left & Right) / 3x8mm CS (4), as shown in www.amazon.com, May 9, 2023, ASIN B08FP58B85 (Year: 2023).

“T-Bone Racing Chassis Skidplate for Traxxas X-Maxx.” Big Squid RC., May 13, 2016 [online], [retrieved on Aug. 24, 2023]. Retrieved from the Internet <URL: <https://www.bigsquidrc.com/t-bone-racing-chassis-skidplate-for-traxxas-x-maxx/>>.

“Front Skid Plate for the Traxxas Slash 2wd.” GPM Parts., Aug. 13, 2015 [online], [retrieved on Aug. 24, 2023]. Retrieved from the Internet <URL: <https://rpmrcproducts.com/shop/chassis-components/skid-plates/traxxas-slash-front-skid-plate/>>.

“Traxxas Maxx Monster Truck Stainless Steel Skid Plates.” GPM Parts., Jul. 1, 2020 [online], [retrieved on Aug. 24, 2023]. Retrieved from the Internet <URL: <https://www.gpmparts.com/traxxas-maxx-monster-truck-stainless-steel-skid-plates-for-front-center-rear-chassis-hollow-version-36pc-set-gpm-txmszsp1b-p-17488.html>>.

Skid Plate, Roof (Body) (With LED Lights), Traxxas Website, No Available Date [Website Visited Jan. 9, 2024], Available on the internet URL: <https://traxxas.com/products/parts/9691> (Year: 2024).

Traxxas Skid Plate, roof (Body) (with LED Lights), Amazon Website, No Available Date [Website Visited Jan. 9, 2024], Available on the internet URL: <https://www.amazon.com/dp/B09N78M2H9/> (Year: 2024).

Traxxas XRT Xtreme Race Truck Bashing, Big Squid Rc Films, as shown in www.youtube.com, Oct. 26, 2022. (Year: 2022).

Hottest RC Car of 2022—Traxxas XRT, as shown in www.youtube.com, Dec. 11, 2022. (Year: 2022).

Traxxas XRT Roof Skid Pads, as shown in www.amainhobbies.com, May 19, 2023. Part #TRA7816 (Year: 2023).

* cited by examiner

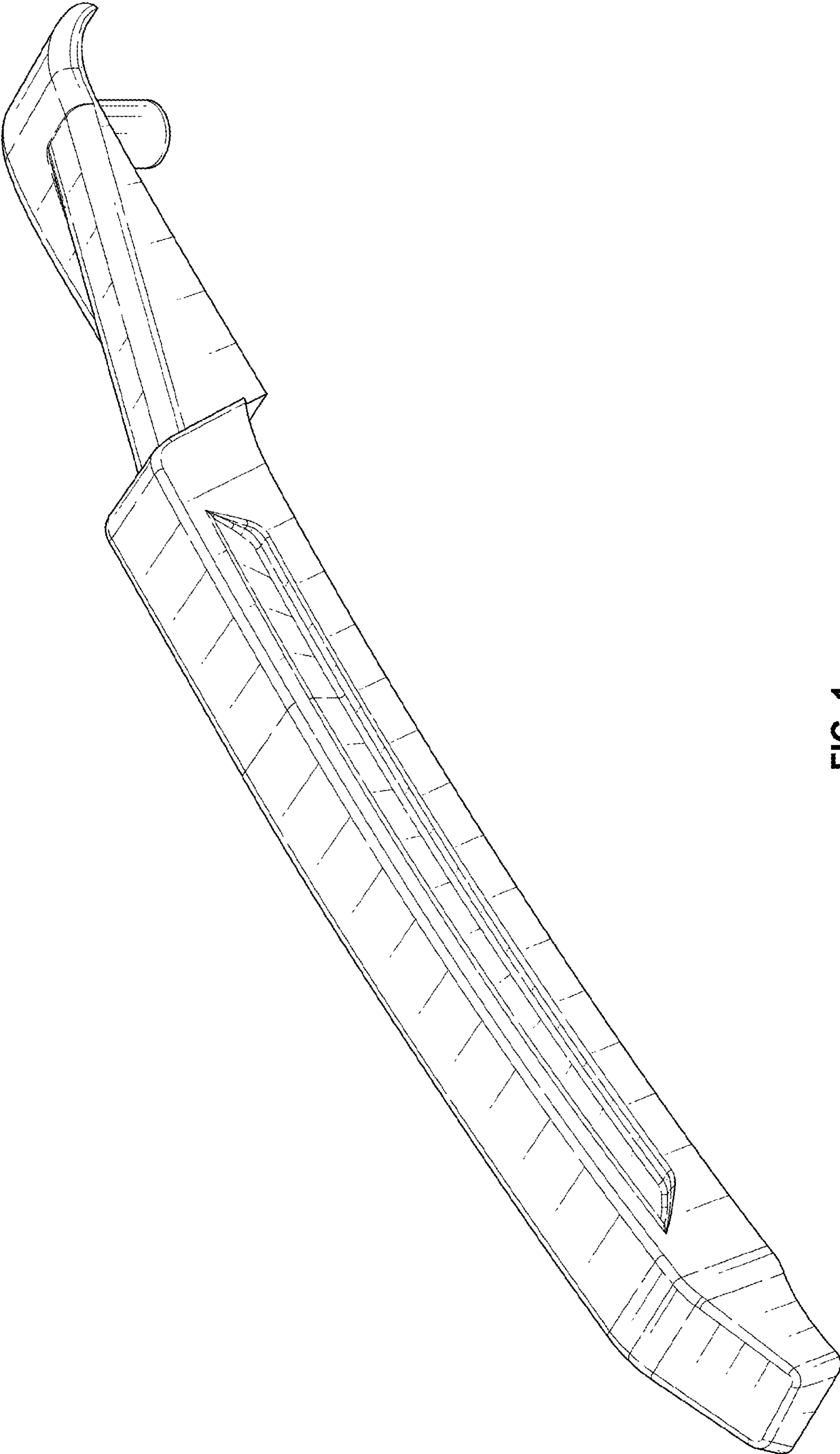

FIG. 1

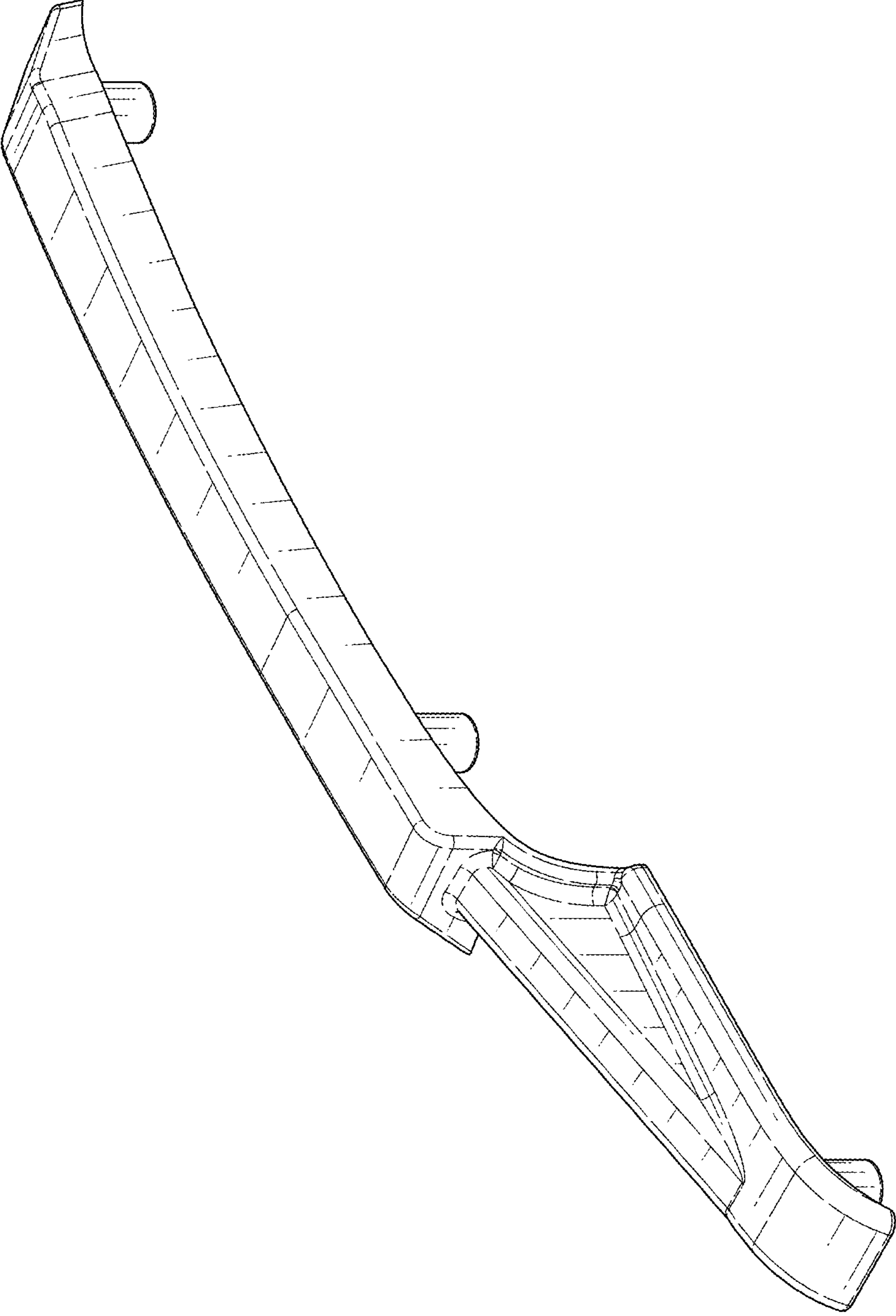

FIG. 2

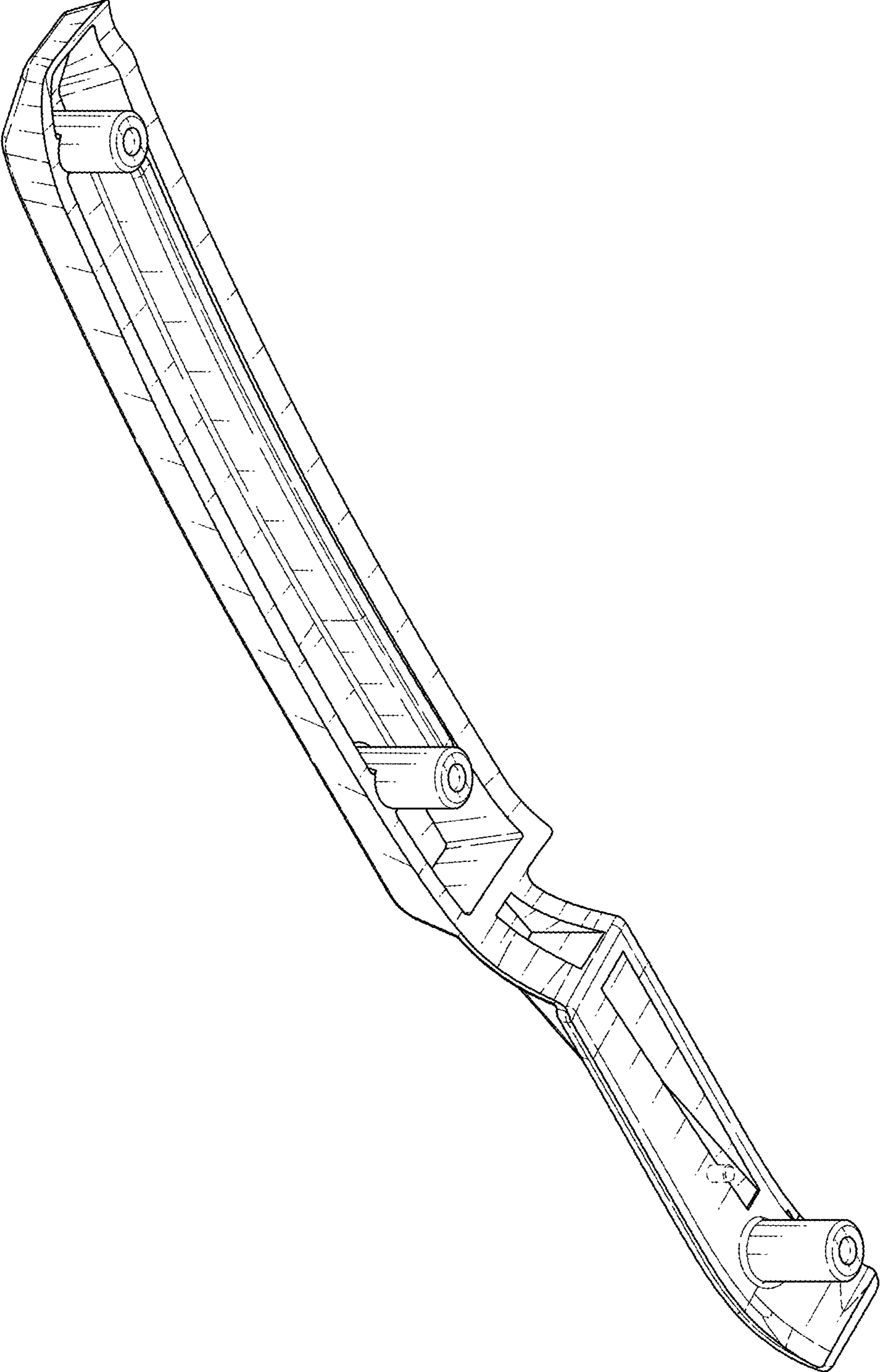

FIG. 3

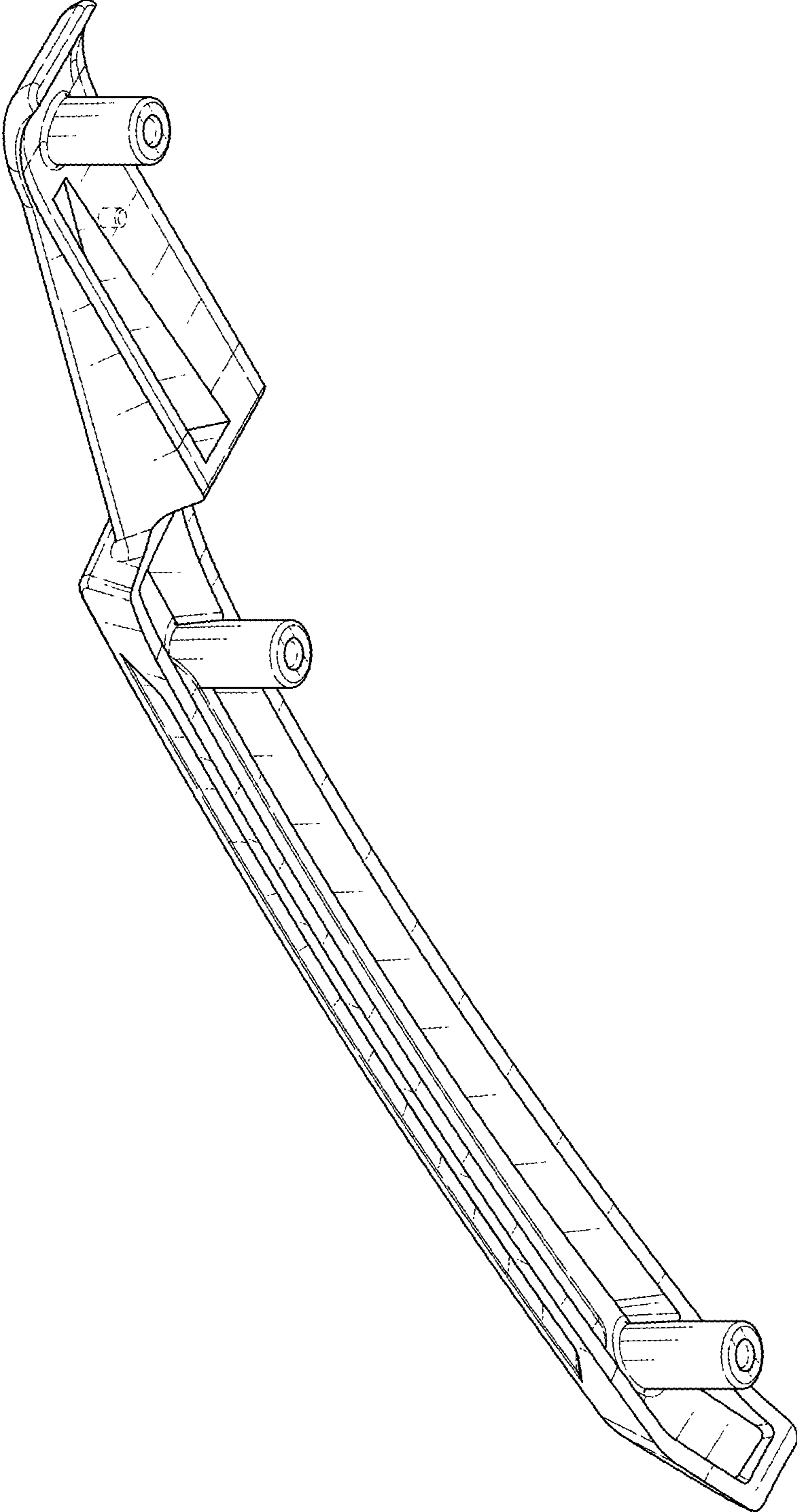

FIG. 4

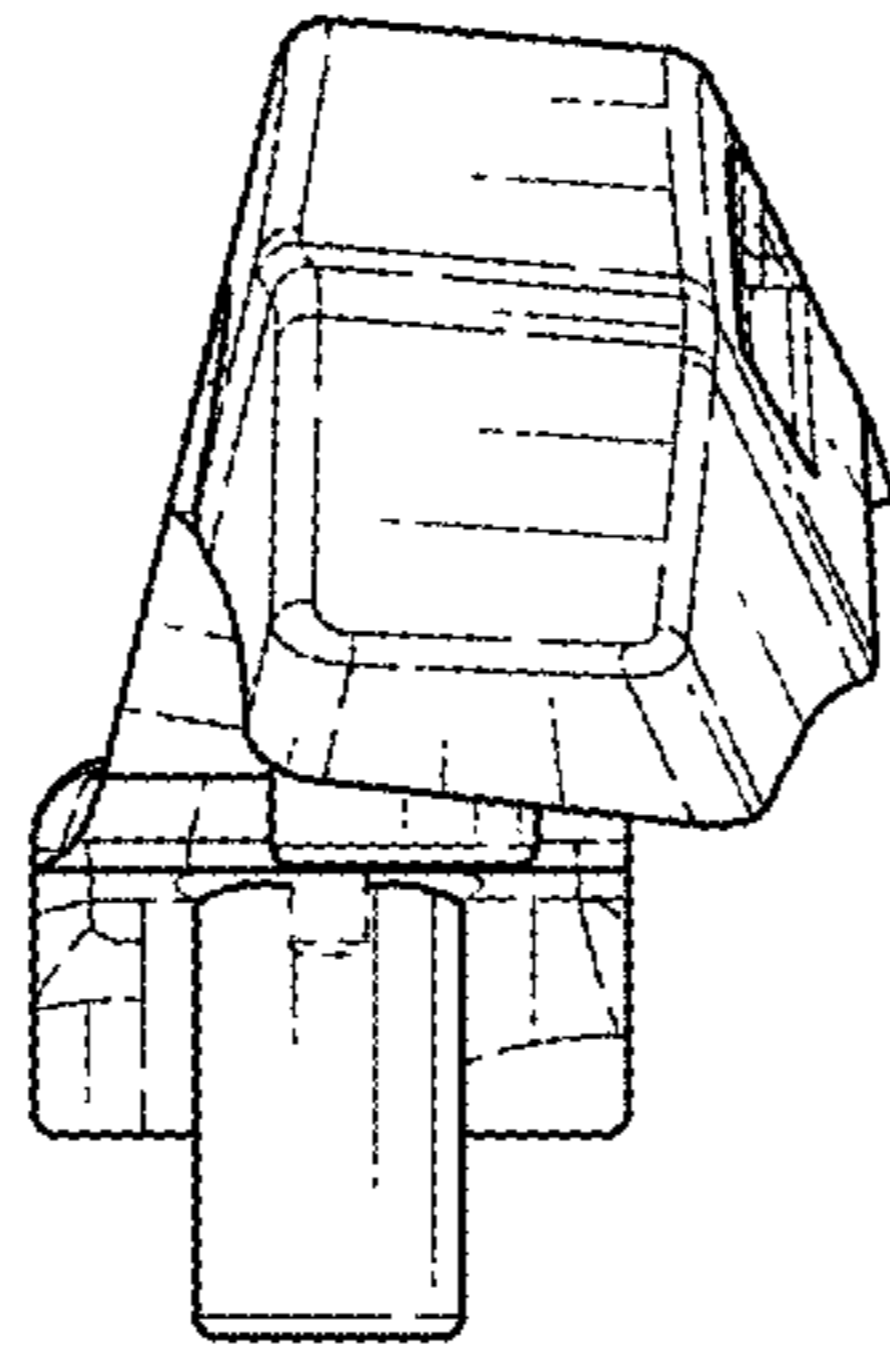

FIG. 5

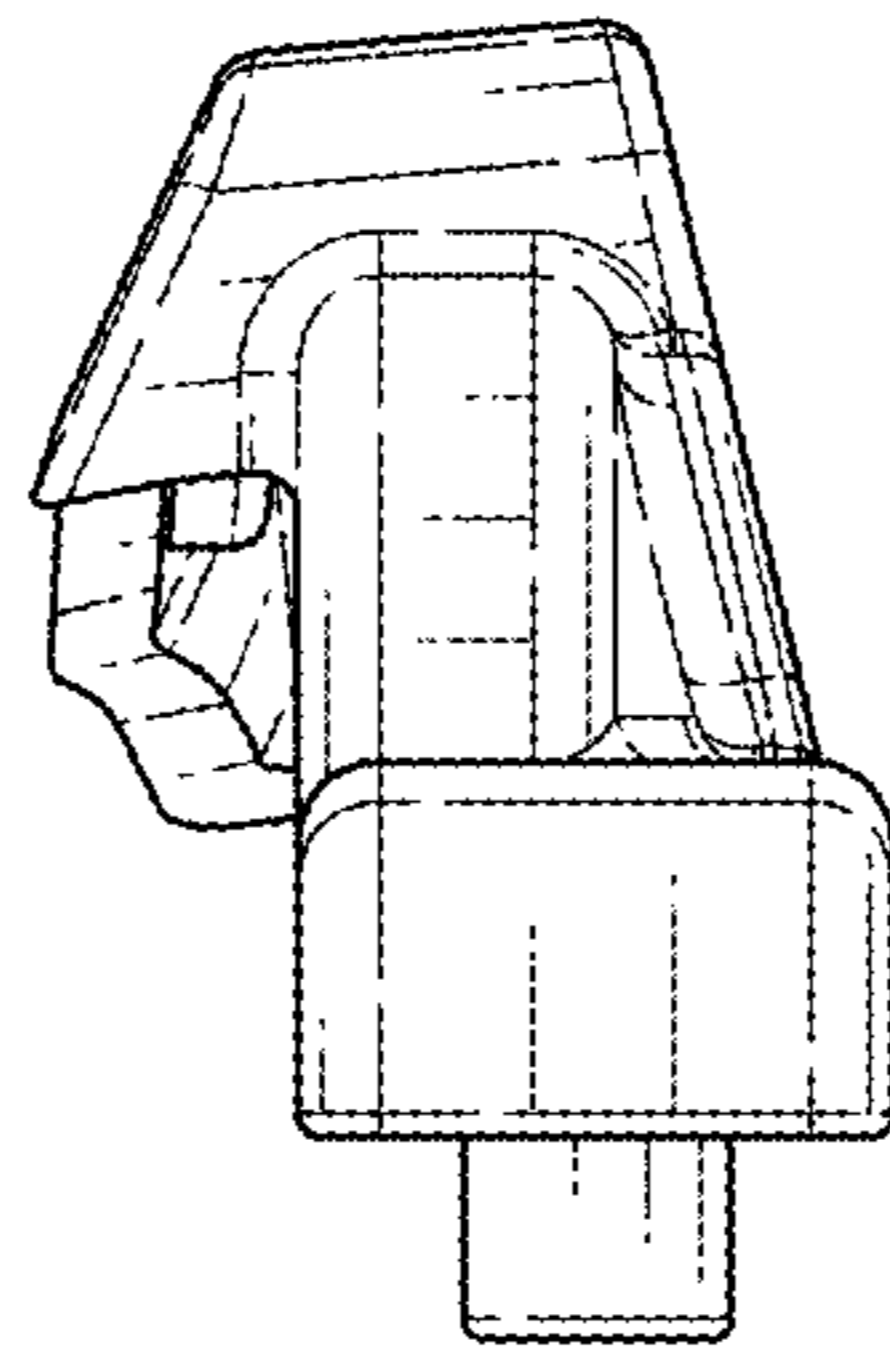

FIG. 6

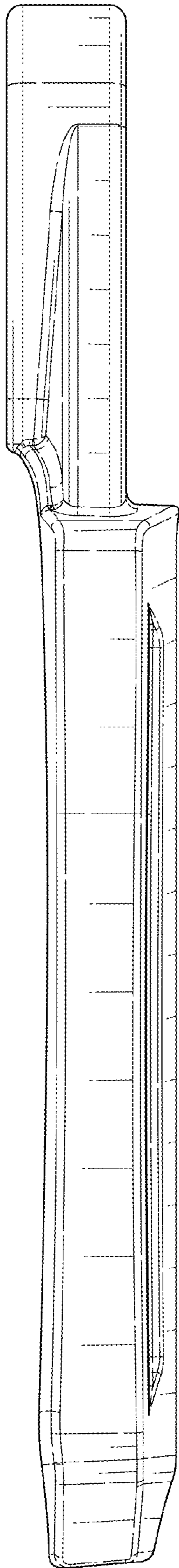

FIG. 7

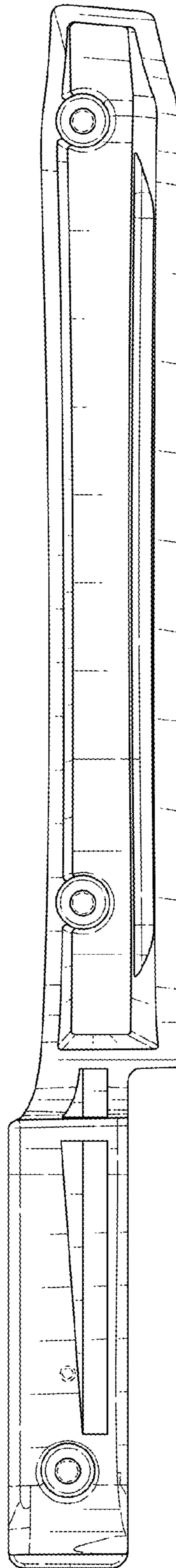

FIG. 8

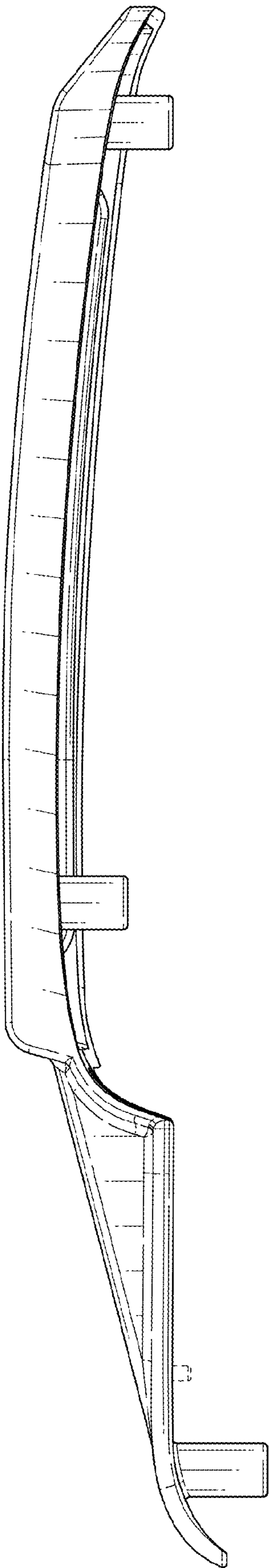

FIG. 9

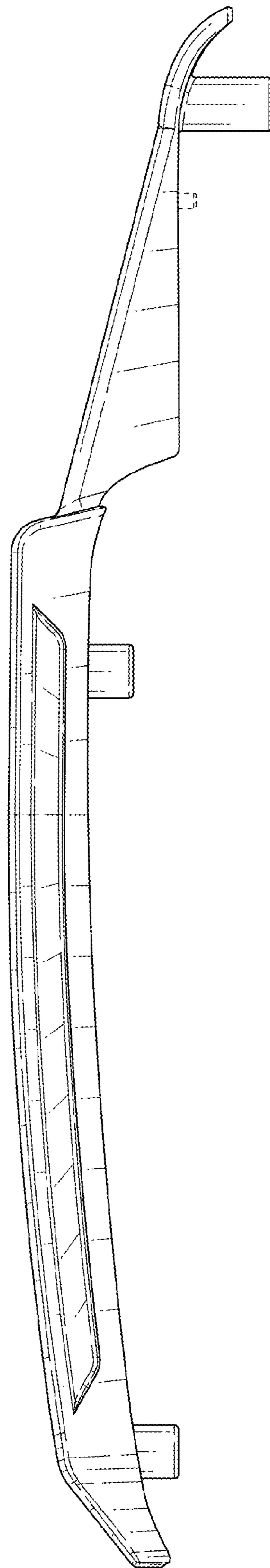

FIG. 10