



US0D1060028S

(12) **United States Design Patent**
Gimström et al.

(10) **Patent No.: US D1,060,028 S**
(45) **Date of Patent: ** Feb. 4, 2025**

(54) **WELDING CONSUMABLE CONTAINER**

FOREIGN PATENT DOCUMENTS

(71) Applicant: **ESAB AB**, Gothenburg (SE)

CN 210213078 U 3/2020
EP 1275595 A2 1/2003

(72) Inventors: **Claes Gimström**, Gothenburg (SE);
Roberto Carlos Guerrero Kees,
Frisco, TX (US); **Gerard F. Klaes**,
Moab, UT (US); **Rodolfo F. Rep**,
Hanover, PA (US); **Mikael Mimer**,
Gothenburg (SE); **Michael Guion**,
Mechanicsburg, PA (US)

(Continued)

OTHER PUBLICATIONS

[Zonon 8 Pcs Stick Welding Electrode Rod Storage], available in Amazon.com, date first available Jul. 1, 2024 [online], [site visited Sep. 13, 2024], Available from the internet URL: https://www.amazon.com/Zonon-Electrode-Container-Airproof-Waterproof/dp/B0D8HZKWSH/ref=sr_1_249_sspa (Year: 2024).*

(Continued)

(73) Assignee: **ESAB AB**, Gothenburg (SE)

(**) Term: **15 Years**

Primary Examiner — Calvin E Vasant

Assistant Examiner — Kaitlyn G Wiltshire

(21) Appl. No.: **29/909,512**

(74) *Attorney, Agent, or Firm* — Edell, Shapiro & Finnan, LLC

(22) Filed: **Aug. 7, 2023**

(57) **CLAIM**

The ornamental design for a welding consumable container, as shown and described.

Related U.S. Application Data

DESCRIPTION

(62) Division of application No. 29/781,653, filed on Apr. 30, 2021, now Pat. No. Des. 998,664.

(51) **LOC (15) Cl.** **09-03**

(52) **U.S. Cl.**
USPC **D9/430; D15/144**

(58) **Field of Classification Search**
USPC D15/122, 7, 144–144.2; D8/356, 360,
D8/29, 29.1–29.2, 61, 68, 69; D9/430,
D9/445; D24/111

(Continued)

FIG. 1 is an isometric perspective front view of a welding consumable container according to the present invention; FIG. 2 is an isometric perspective rear view of the welding consumable container of FIG. 1; FIG. 3 is a front view of the welding consumable container of FIG. 1; FIG. 4 is a rear view of the welding consumable container of FIG. 1; FIG. 5 is a right side view of the welding consumable container of FIG. 1; FIG. 6 is a left side view of the welding consumable container of FIG. 1; FIG. 7 is a top view of the welding consumable container of FIG. 1; and, FIG. 8 is a bottom view of the welding consumable container of FIG. 1.

(56) **References Cited**

U.S. PATENT DOCUMENTS

D75,980 S 8/1928 Pfeiffer
D82,536 S 11/1930 Eberhardt

(Continued)

1 Claim, 7 Drawing Sheets

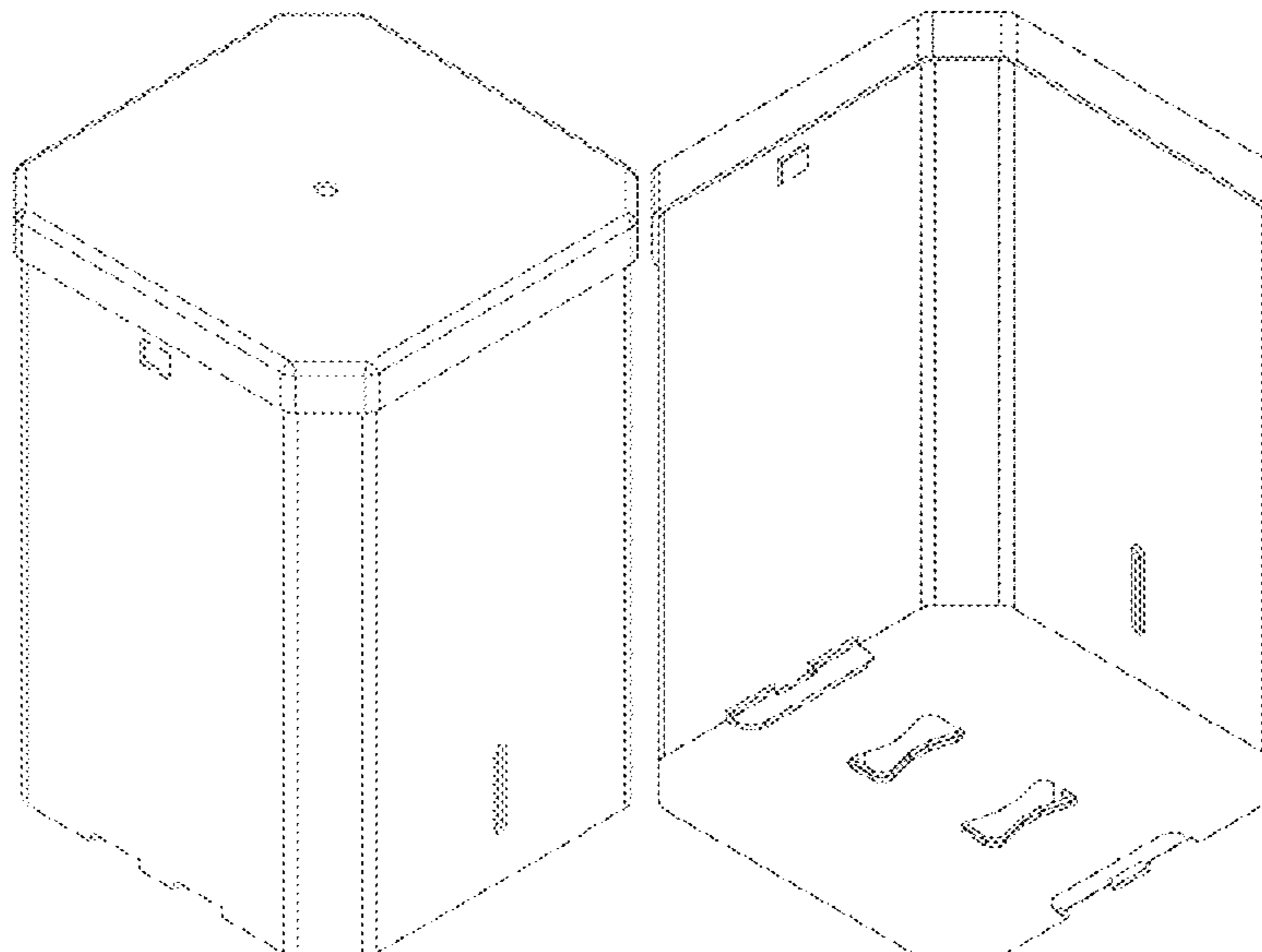

(58) **Field of Classification Search**
 CPC . B65D 85/04; B23K 9/00; B23K 9/12; B23K 9/28; B23K 9/32; B23K 9/167; B23K 37/02; B23K 37/0294; B23K 11/115; B23K 5/00; B23K 3/00; B23K 3/021; B23K 1/00; B29C 66/43; B29C 66/861; B29C 66/8618; B29C 65/02; B29C 65/04; B29C 65/18; B29C 65/74
 See application file for complete search history.

(56) **References Cited**

U.S. PATENT DOCUMENTS

D97,510	S	11/1935	Shirriff	
D235,248	S	6/1975	Bennett	
4,160,533	A	7/1979	Kotzur et al.	
4,623,063	A	11/1986	Balkin	
D315,626	S *	3/1991	Delmerico	D34/1
5,485,968	A	1/1996	Fujioka	
D397,612	S	9/1998	Lipnick	
D399,738	S	10/1998	B-Jensen et al.	
D429,429	S	8/2000	Murphy	
6,237,768	B1	5/2001	Cipriani	
6,481,575	B2	11/2002	Cipriani	
D472,466	S	4/2003	Weinstein et al.	
6,564,943	B2	5/2003	Barton et al.	
6,648,141	B2	11/2003	Land	
6,827,217	B2	12/2004	Matsuguchi et al.	
6,857,521	B2	2/2005	Cantu-Gonzalez	
6,889,835	B2	5/2005	Land	
6,913,145	B2	7/2005	Barton et al.	
6,938,767	B2	9/2005	Gelmetti	
7,017,742	B2	3/2006	Dragoo et al.	
D521,204	S *	5/2006	Lauer	D34/1
7,124,889	B2	10/2006	Fuemmeler	
7,152,735	B2	12/2006	Dragoo et al.	
7,188,816	B2	3/2007	Aoki et al.	
7,191,968	B2	3/2007	Kuper	
7,198,152	B2	4/2007	Barton et al.	
7,220,942	B2	5/2007	Barton et al.	
7,309,038	B2	12/2007	Carroscia	
7,311,285	B2	12/2007	Rauchs et al.	
7,331,457	B2	2/2008	Cipriani	
7,353,947	B2	4/2008	Weissbrod	
7,377,388	B2	5/2008	Hsu et al.	
7,398,881	B2	7/2008	Barton et al.	
7,552,826	B2	6/2009	Watanabe	
7,748,530	B2	7/2010	Hsu et al.	
7,866,586	B2	1/2011	Fabian	
7,905,439	B2	3/2011	Fabian	
7,938,352	B2	5/2011	Fabian	
7,958,996	B2	6/2011	Hsu et al.	
8,127,923	B2	3/2012	Gelmetti	
8,245,846	B2	8/2012	Nicklas	
8,313,054	B2	11/2012	Carroscia et al.	
D672,645	S	12/2012	Giannini et al.	
8,365,912	B2	2/2013	Carroscia et al.	
8,485,358	B2	7/2013	Barhorst et al.	
8,534,581	B2	9/2013	Cooper et al.	
8,550,245	B2	10/2013	Dragoo et al.	
8,608,003	B2	12/2013	Uno	
D698,242	S	1/2014	Hartman et al.	
8,631,936	B2	1/2014	Rolfes et al.	
8,662,003	B1	3/2014	Cooper et al.	
8,668,086	B2	3/2014	Gelmetti	
8,752,782	B2	6/2014	Matthews, III	
8,794,561	B2	8/2014	Fabian	
8,882,018	B2	11/2014	Gelmetti	
D719,824	S	12/2014	Wagner	
8,931,638	B2	1/2015	Weissbrod	
8,967,520	B2	3/2015	Matthews, III et al.	
8,967,690	B2	3/2015	Cooper et al.	
9,010,532	B2	4/2015	Nicklas	
9,132,988	B2	9/2015	Weissbrod	
9,193,558	B2	11/2015	Matthews et al.	
9,260,269	B2	2/2016	Weissbrod et al.	

9,265,307	B2	2/2016	Cooper et al.	
9,421,633	B2	8/2016	Weissbrod et al.	
9,493,294	B2	11/2016	Nicklas et al.	
9,604,742	B2	3/2017	Yasutomi et al.	
D800,552	S	10/2017	Silverman	
9,868,610	B2	1/2018	Weissbrod et al.	
9,873,587	B2	1/2018	Matthews, III et al.	
9,908,662	B2	3/2018	Campagna et al.	
9,919,857	B2	3/2018	Weissbrod	
9,950,857	B1	4/2018	Gelmetti	
D841,443	S	2/2019	Foster, II et al.	
10,294,065	B2	5/2019	Gelmetti	
D863,939	S	10/2019	Foster, II et al.	
D906,802	S	1/2021	Chi	
D934,678	S *	11/2021	Eriksson-Ahuja	D9/430
D966,100	S *	10/2022	Naukkarinen	D9/432
D991,299	S *	7/2023	Gimström	D9/430
D998,664	S *	9/2023	Gimström	D9/430
D998,665	S *	9/2023	Gimström	D9/430
D1,026,958	S *	5/2024	Hedberg	D15/7
D1,039,135	S *	8/2024	Hainsworth	D24/111
2003/0010663	A1 *	1/2003	Barton	B65D 5/5033 206/408
2003/0042163	A1	3/2003	Cipriant	
2004/0211851	A1	10/2004	Barton et al.	
2006/0124489	A1	6/2006	Dragoo et al.	
2006/0196794	A1	9/2006	Nicklas	
2006/0249611	A1	11/2006	Carroscia et al.	
2007/0045141	A1	3/2007	Gelmetti	
2007/0051716	A1	3/2007	Hartman et al.	
2007/0175965	A1	8/2007	Carroscia	
2008/0142626	A1	6/2008	Park	
2008/0142627	A1	6/2008	Lee	
2009/0235608	A1	9/2009	Kosny et al.	
2010/0282630	A1 *	11/2010	Cooper	B65D 85/04 206/413
2011/0132786	A1	6/2011	Yasutomi et al.	
2011/0174792	A1	7/2011	Gelmetti	
2011/0186677	A1 *	8/2011	Carroscia	B65H 57/06 242/615.4
2012/0097672	A1 *	4/2012	Carroscia	B65D 85/04 220/23.83
2012/0109833	A1	5/2012	Agosti et al.	
2013/0081967	A1	4/2013	Gaul et al.	
2013/0082132	A1	4/2013	Gaul	
2013/0218790	A1	8/2013	Agosti et al.	
2014/0183294	A1	7/2014	Weissbrod	
2014/0246532	A1	9/2014	Carroscia et al.	
2014/0361115	A1 *	12/2014	Gelmetti	B65H 57/18 242/593
2015/0232228	A1 *	8/2015	Weissbrod	B65D 85/70 220/268
2015/0353270	A1	12/2015	Gaul	
2017/0295967	A1	10/2017	Bucksch	
2018/0207744	A1	7/2018	Stoecker	
2018/0282055	A1	10/2018	Wiener et al.	
2018/0362287	A1	12/2018	Weissbrod	
2019/0070686	A1	3/2019	Kooken et al.	
2019/0072941	A1	3/2019	Kooken et al.	
2020/0307899	A1 *	10/2020	Cooper	B65D 5/5033
2023/0011011	A1 *	1/2023	Gelmetti	B23K 9/133
2023/0322519	A1 *	10/2023	Gelmetti	B65D 85/04 242/129
2024/0051733	A1 *	2/2024	Gimström	B65D 5/5033

FOREIGN PATENT DOCUMENTS

JP	2012012025	A	1/2012
KR	100359124	B1	11/2002
WO	201871289	A1	4/2018
WO	2018234392	A1	12/2018
WO	2018234393	A1	12/2018
WO	2019157411	A2	8/2019

OTHER PUBLICATIONS

[11 Lb Portable Welding Rod Oven], available in Amazon.com, date first available Apr. 24, 2024 [online], [site visited Sep. 13, 2024],

(56)

References Cited

OTHER PUBLICATIONS

Available from the internet URL: https://www.amazon.com/Ridge-Products-Portable-Welding-Oven/dp/B0D52H7TLW/ref=sr_1_52_sspa (Year: 2024).*

International Preliminary Report on Patentability for International Application No. PCT/IB2022/000256 dated Oct. 24, 2023, 8 pages.
Notification of Transmittal of International Search Report and Written Opinion including International Search Report and Written Opinion for International Application No. PCT/IB2022/000256, dated Sep. 16, 2022, 15 pages.

* cited by examiner

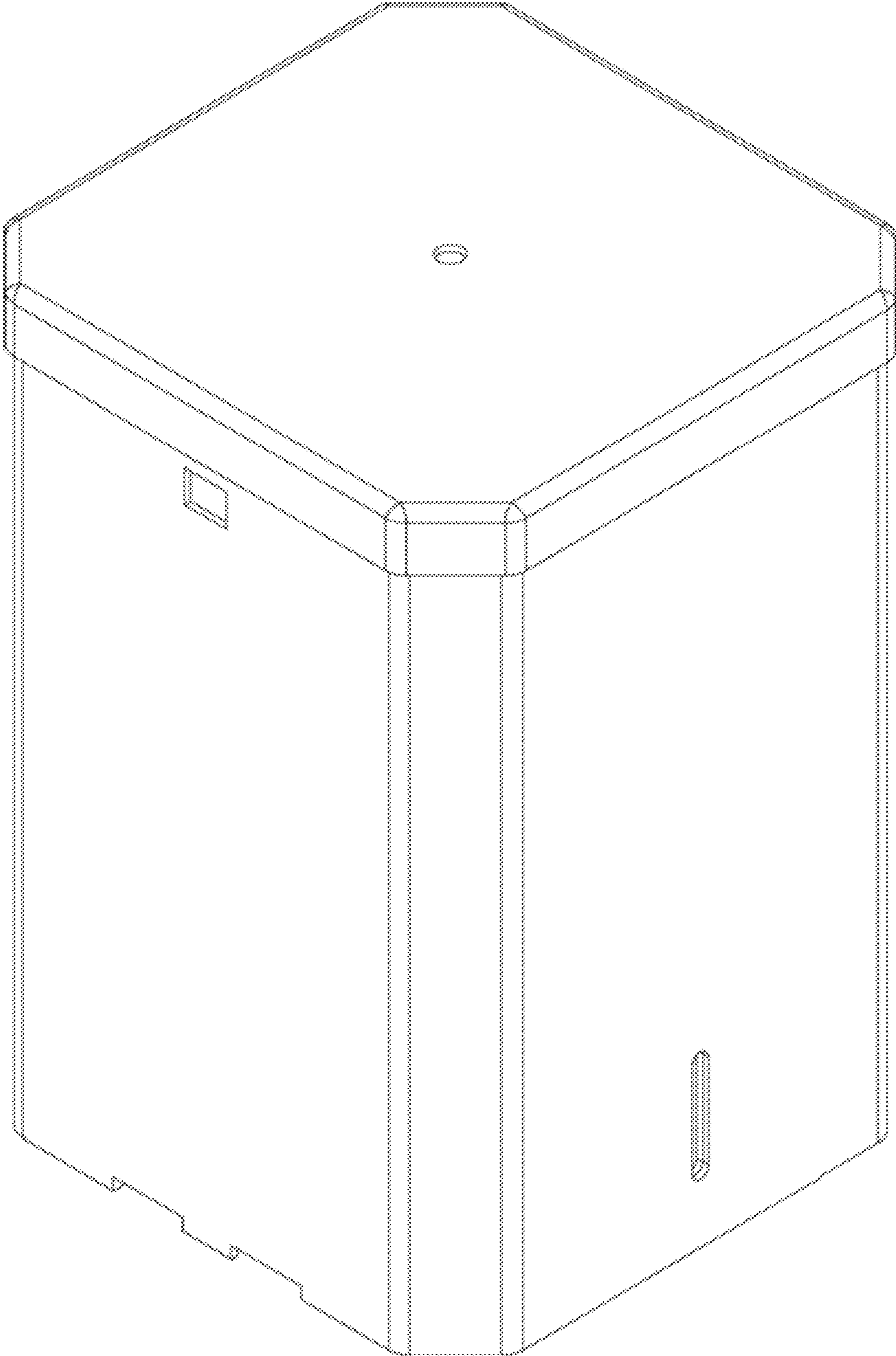

FIG. 1

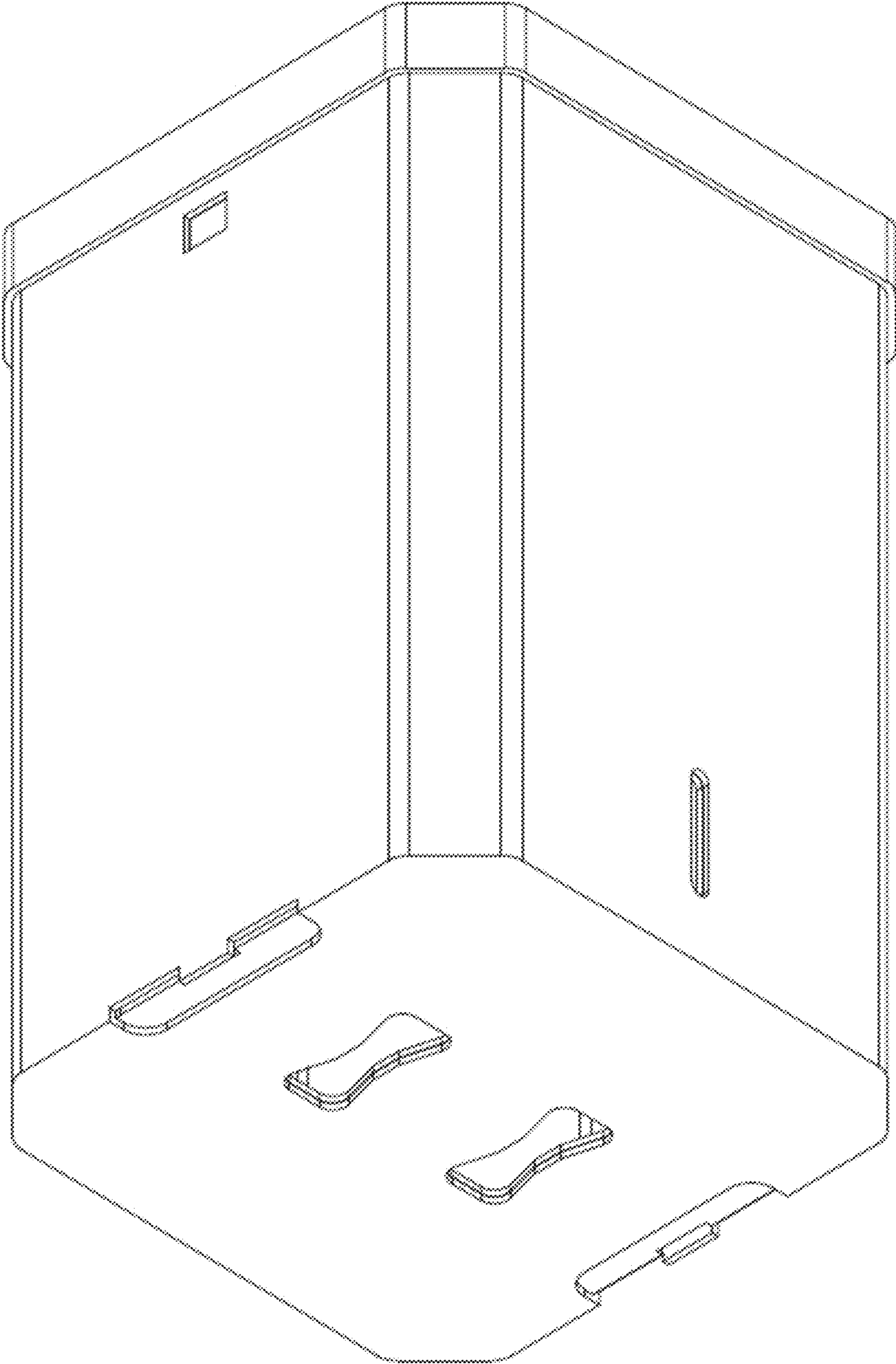

FIG.2

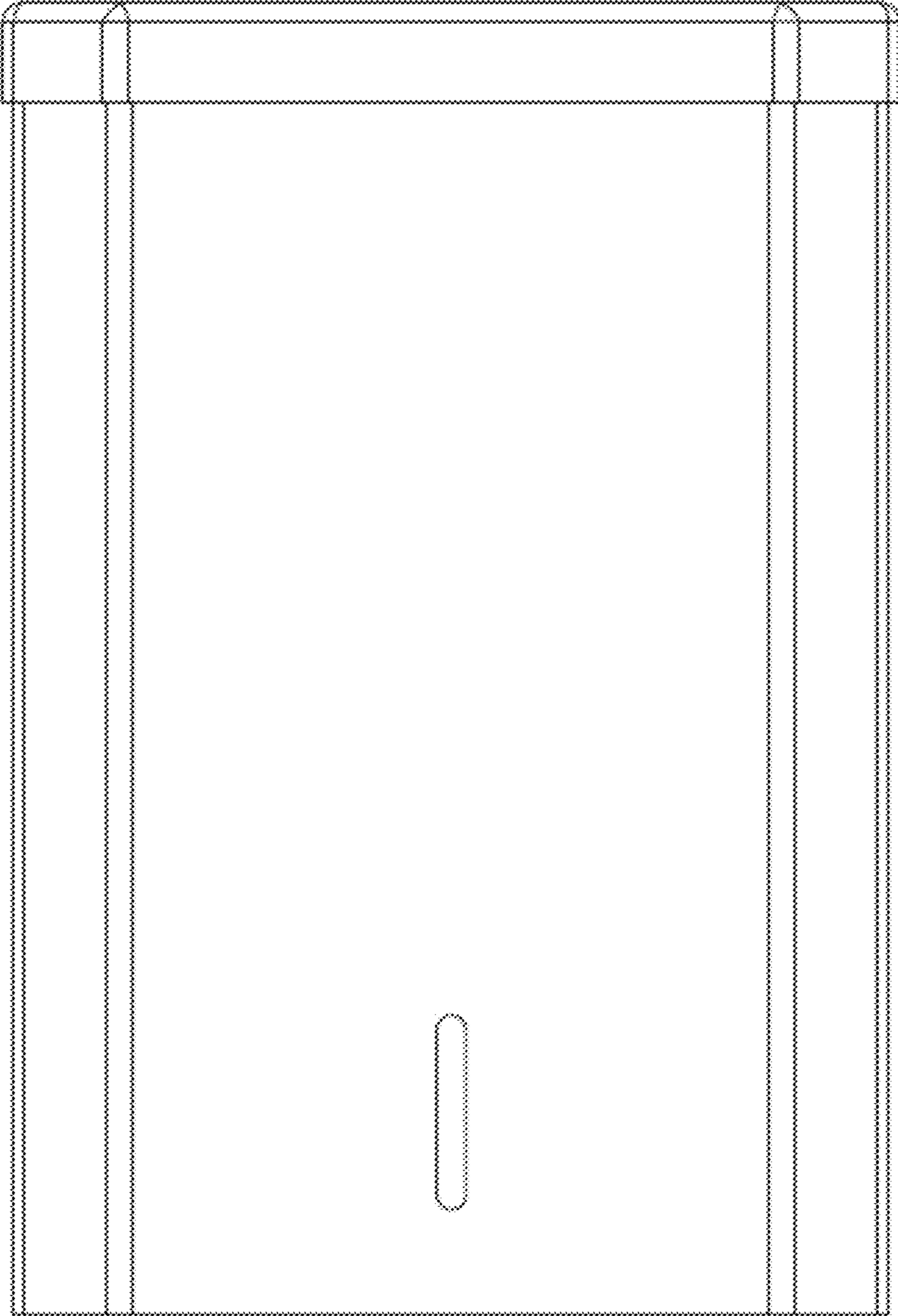

FIG.3

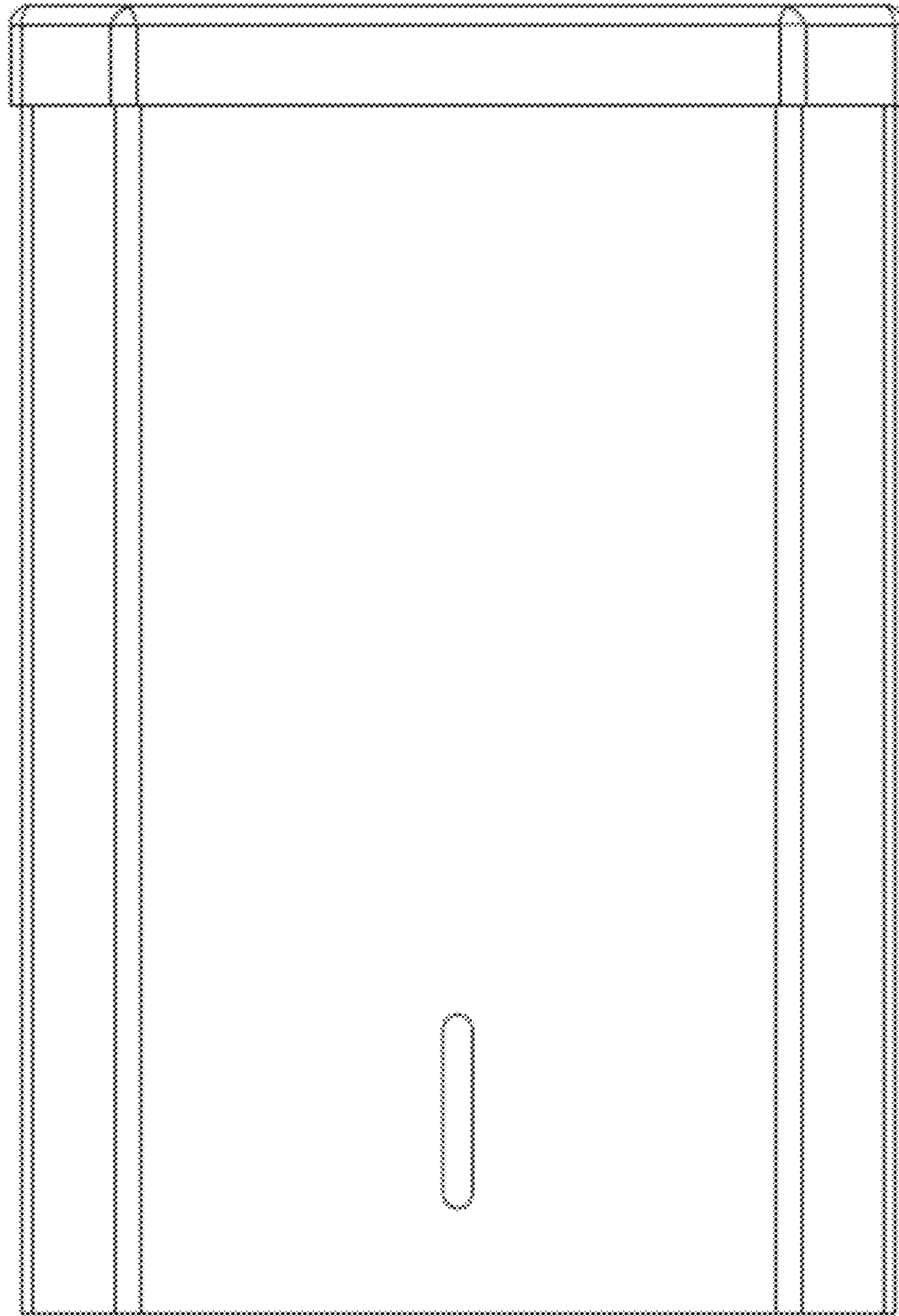

FIG.4

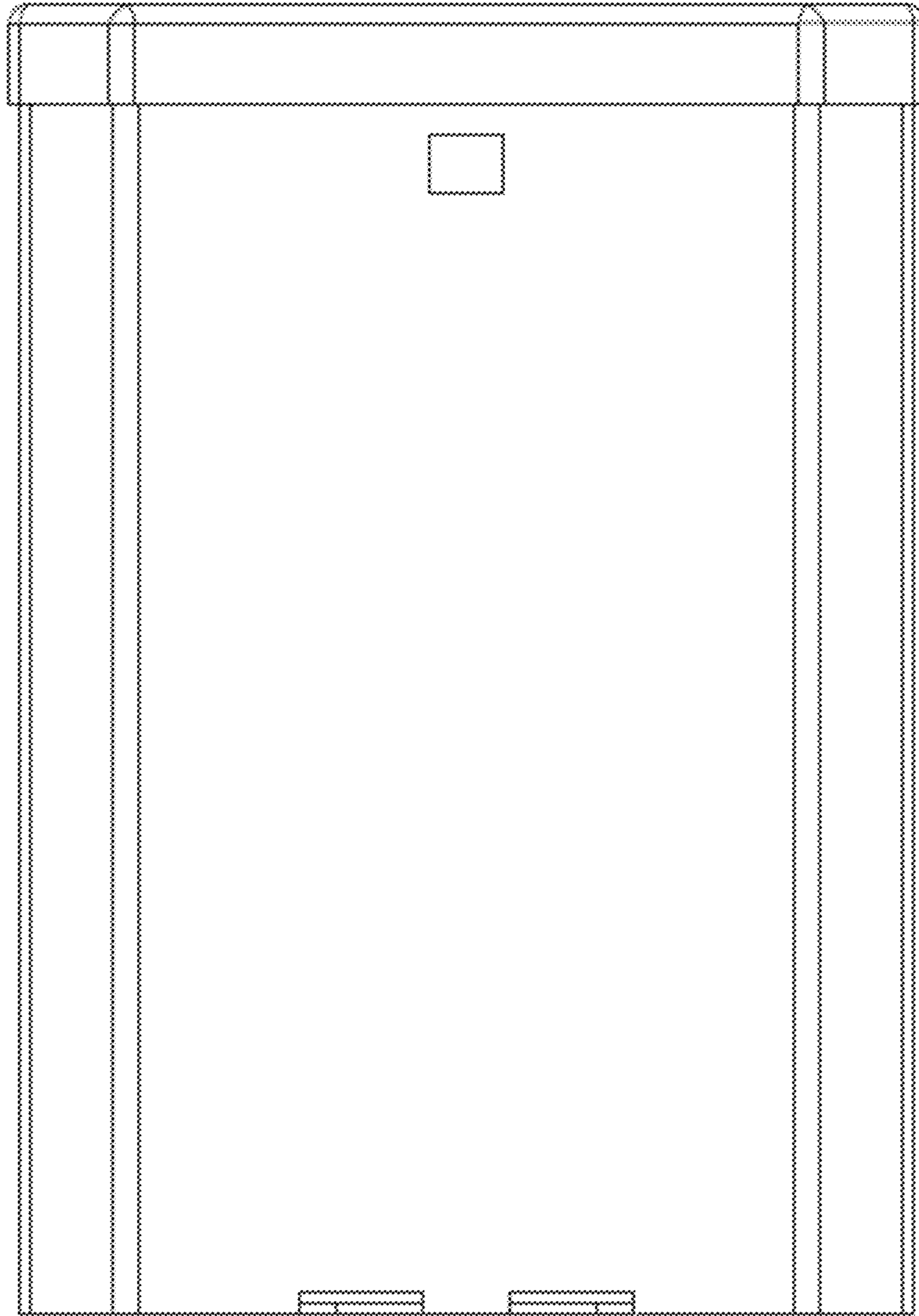

FIG.5

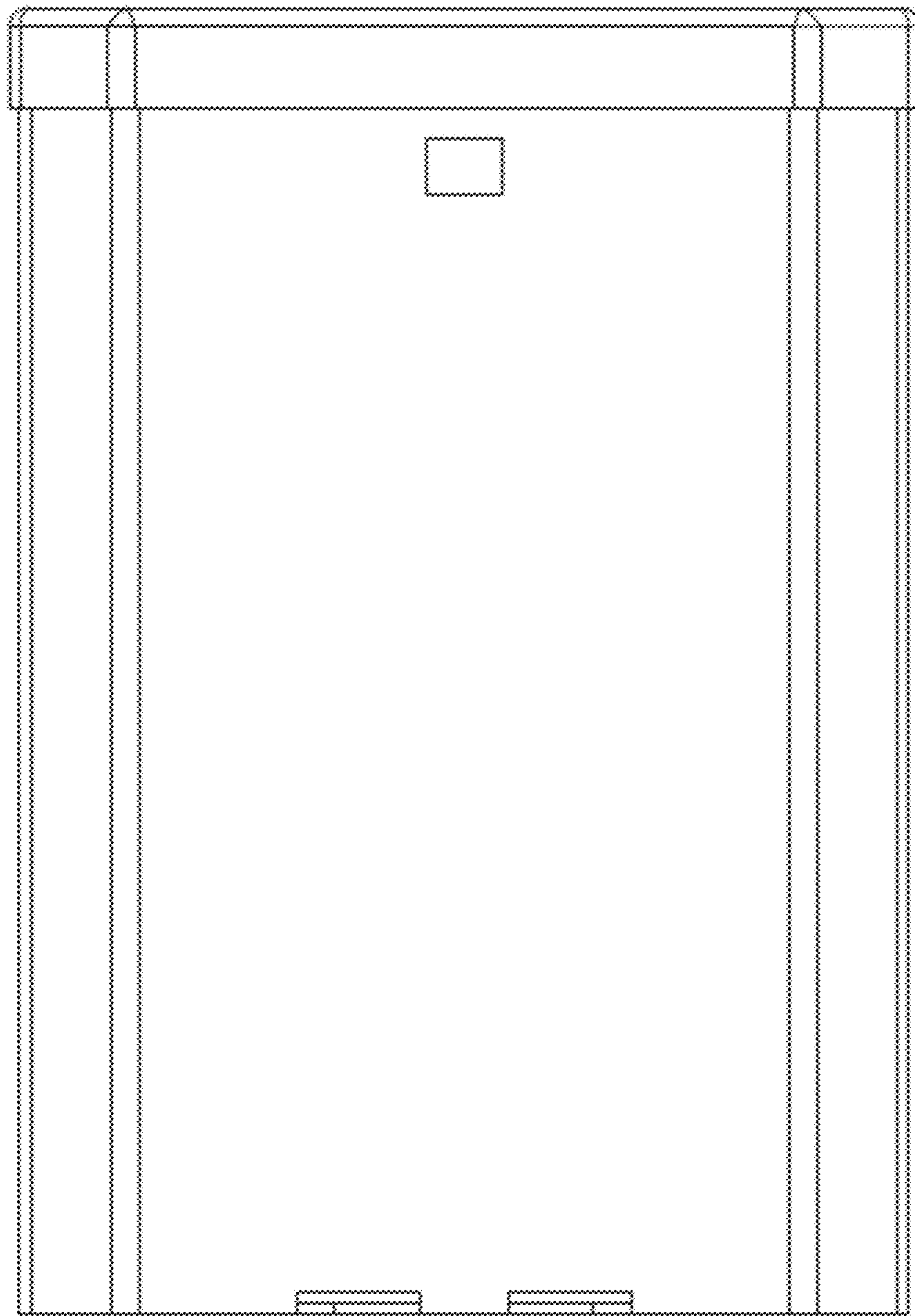

FIG.6

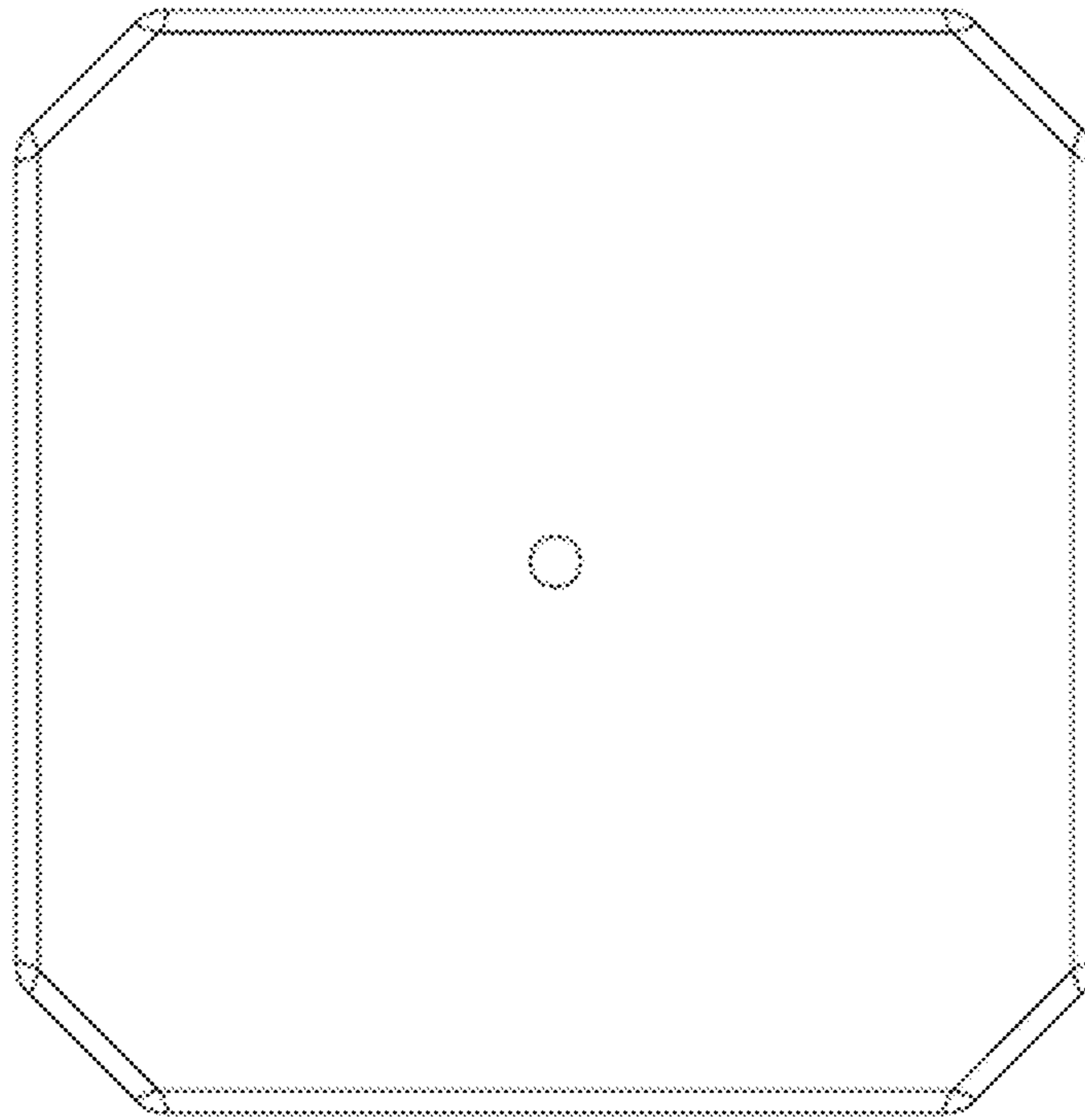

FIG.7

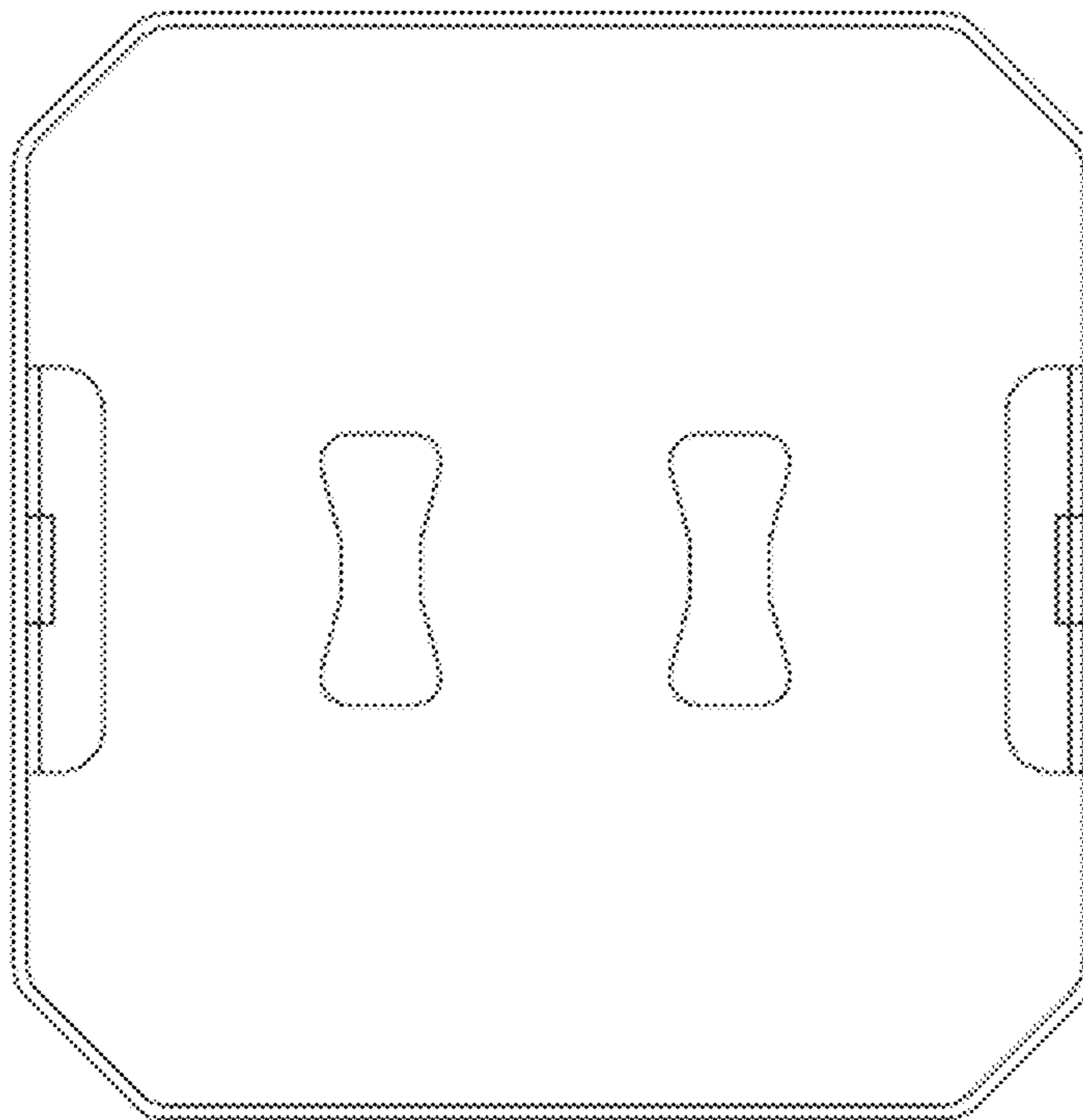

FIG.8