



US0D1057557S

(12) **United States Design Patent** (10) **Patent No.:** **US D1,057,557 S**  
**Humberstone et al.** (45) **Date of Patent:** **\*\* Jan. 14, 2025**

(54) **LOCKING TAB FOR TAMPER-EVIDENT BOX**

(71) Applicant: **Pratt Corrugated Holdings, Inc.**,  
Brookhaven, GA (US)

(72) Inventors: **Robert F. Humberstone**, Port  
Charlotte, FL (US); **Hector Nava**,  
Dallas, TX (US)

(73) Assignee: **Pratt Corrugated Holdings, Inc.**,  
Brookhaven, GA (US)

(\*\*) Term: **15 Years**

(21) Appl. No.: **29/748,620**

(22) Filed: **Aug. 31, 2020**

(51) **LOC (15) Cl.** ..... **09-03**

(52) **U.S. Cl.**  
USPC ..... **D9/435; D9/432**

(58) **Field of Classification Search**  
USPC ..... D3/201, 273, 294; D7/601, 602;  
D9/414-418, 419-421, 423, 430-436,  
D9/443, 444, 446, 456, 449; D19/1, 2, 3,  
D19/26, 27, 33, 65, 75, 100  
CPC . B65D 5/54; B65D 5/66; B65D 85/36; B65D  
5/546; B65D 5/6626  
See application file for complete search history.

(56) **References Cited**

**U.S. PATENT DOCUMENTS**

636,806 A 11/1899 Johnstone  
916,503 A 3/1909 Thompson  
1,108,464 A 8/1914 Morey

(Continued)

**FOREIGN PATENT DOCUMENTS**

DE 2846467 5/1980  
DE 102008037953 4/2009

(Continued)

**OTHER PUBLICATIONS**

US D1,036,252 S, 07/2024, Ball (withdrawn)

(Continued)

*Primary Examiner* — Catherine S Posthauer

*Assistant Examiner* — Crystal R Ponce

(74) *Attorney, Agent, or Firm* — Taylor English Duma  
LLP

(57) **CLAIM**

The ornamental design for a locking tab for tamper-evident box, as shown and described.

**DESCRIPTION**

FIG. 1 is a top perspective view of the claimed design showing a box embodying the claimed design in an assembled and closed position.

FIG. 2 is a first side or left side elevation view thereof. A second side or right side elevation view is a mirror of the left side elevation view.

FIG. 3 is a front elevation view thereof.

FIG. 4 is a rear elevation view thereof.

FIG. 5 is a top plan view thereof.

FIG. 6 is a bottom plan view thereof.

FIG. 7 is a top perspective view of the claimed design showing the box embodying the claimed design in a folded and partially open position and with the locking tab separated from a remaining portion of the box; and,

FIG. 8 is a top plan view of the claimed design showing the box embodying the claimed design in an unfolded, flat position (i.e., as a blank) and facing an outer surface of the box.

The evenly broken lines are shown for the purpose of illustrating fold lines and environmental subject matter of an exemplary box, neither of which form any part of the claimed design. The long-dash-short-dash broken lines represent perforations forming part of the claimed design. The dot-dash broken lines represent the boundaries of the claim and form no part thereof.

**1 Claim, 6 Drawing Sheets**

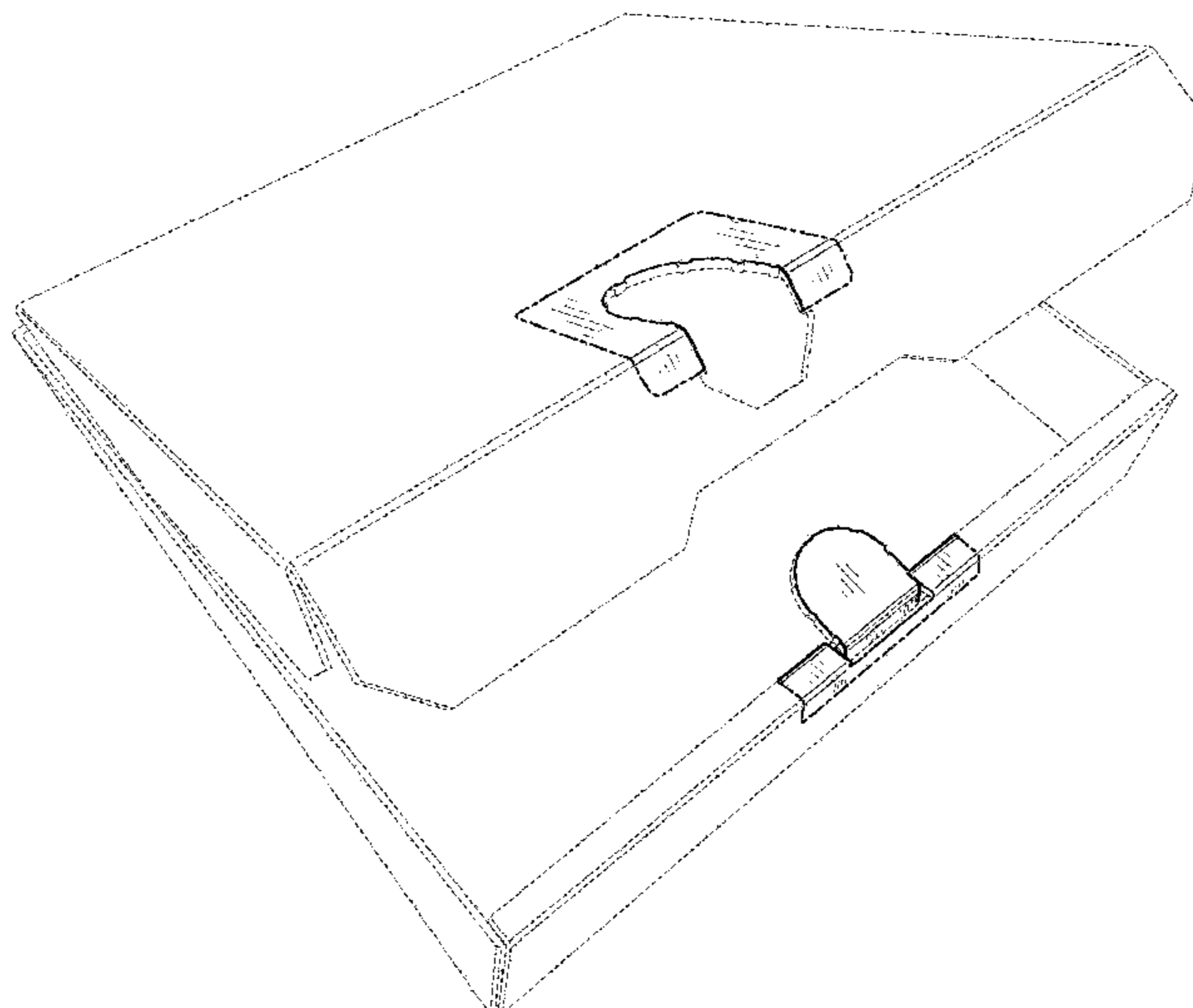

(56)

References Cited

U.S. PATENT DOCUMENTS

1,277,459 A	9/1918	Myers	8,608,050 B2	12/2013	Seliger et al.
1,306,574 A	6/1919	Boerlin	D707,123 S	6/2014	Marchetti et al.
1,470,141 A	10/1923	Bryson	D735,576 S	8/2015	Aldridge
1,530,644 A	3/1925	Blandford	9,327,866 B2	5/2016	Strom et al.
1,765,964 A	6/1930	Berton	D758,851 S	6/2016	Binder et al.
2,028,677 A	1/1936	Lupton	D764,280 S	8/2016	Carnu
2,044,701 A	6/1936	Junkin	D767,989 S	10/2016	Nietert et al.
2,228,181 A	1/1941	Perryman	9,481,486 B2	11/2016	Nameth et al.
2,572,159 A	10/1951	Kells et al.	9,522,761 B2	12/2016	Baker et al.
2,834,531 A	5/1958	Struble	9,694,837 B2	7/2017	Ryan
D196,883 S	11/1963	Robinson	D798,709 S *	10/2017	Chen ..... D9/433
3,225,914 A	12/1965	Klein	9,878,818 B2	1/2018	Grajales et al.
3,233,818 A	2/1966	Bixler	10,017,292 B1	7/2018	Anderson et al.
3,235,167 A	2/1966	Svensson	D831,330 S *	10/2018	Kim ..... D3/203.1
3,263,899 A	8/1966	Collura et al.	10,086,972 B2	10/2018	Hajek
3,356,282 A	12/1967	Layne, Sr.	D834,411 S *	11/2018	Vanderhulst ..... D9/432
3,451,535 A	6/1969	Caplan	10,118,726 B2	11/2018	James et al.
D214,879 S	8/1969	Roccaforte et al.	D848,835 S *	5/2019	Exner ..... D9/423
3,462,066 A	8/1969	Farquhar	10,364,062 B2	7/2019	Bressan et al.
D215,414 S	9/1969	Roccaforte	D859,984 S *	9/2019	Li ..... D9/432
3,512,823 A	5/1970	D'Esposito	D863,958 S	10/2019	Tidwell et al.
3,580,482 A	5/1971	Witte	D866,312 S	11/2019	Ito
3,690,542 A	9/1972	Jernstrom	10,486,850 B1	11/2019	Cook et al.
3,827,624 A	8/1974	Dogliotti	D874,921 S *	2/2020	Zhao ..... D9/420
3,949,931 A	4/1976	Hall	D875,521 S *	2/2020	Elman ..... D9/420
4,046,311 A	9/1977	Voytko	D876,819 S *	3/2020	Kim ..... D3/203.1
4,428,525 A	1/1984	Brauner	D888,551 S *	6/2020	Kim ..... D9/420
4,471,902 A	9/1984	Skaggs	D892,632 S	8/2020	Bogdziewicz
4,516,718 A	5/1985	Forbes	10,787,288 B1	9/2020	Garthaffner
4,600,140 A	7/1986	Milliens	D911,833 S *	3/2021	Toroyan ..... D9/416
4,607,786 A	8/1986	Weaver	D914,495 S	3/2021	Wikstrom
4,752,028 A	6/1988	Ogura	11,180,278 B2	11/2021	Bressan et al.
4,765,535 A	8/1988	Michetti	11,225,354 B2	1/2022	Dixon
4,830,270 A	5/1989	Holmes	11,230,404 B2	1/2022	Sollie et al.
4,953,779 A	9/1990	Densen	D946,768 S *	3/2022	Kemper ..... D24/189
5,139,195 A	8/1992	McClure	11,286,081 B2	3/2022	Collis et al.
5,232,087 A	8/1993	Schluger	11,319,140 B2	5/2022	Modha et al.
5,259,552 A	11/1993	Kuchenbecker	D955,875 S *	6/2022	Sill ..... D9/431
5,263,634 A	11/1993	Korine	11,377,252 B2	7/2022	Borst, Sr. et al.
5,350,108 A	9/1994	Friar et al.	D964,851 S	9/2022	Aloisio et al.
5,368,225 A	11/1994	Ritter	D965,433 S *	10/2022	Wikstrom ..... D9/449
5,402,929 A	4/1995	Ritter et al.	D968,950 S	11/2022	Sollie et al.
5,452,845 A	9/1995	Ritter	11,511,921 B1	11/2022	Wikstrom et al.
5,507,428 A	4/1996	Robinson et al.	D977,966 S *	2/2023	Fang ..... D9/432
5,535,940 A	7/1996	Olds	D977,967 S	2/2023	Sollie et al.
5,722,585 A	3/1998	Redl	D981,873 S *	3/2023	Valentine ..... D9/733
D394,383 S	5/1998	Bradfield	11,661,246 B2	5/2023	Sill et al.
5,799,864 A	9/1998	Mertz	11,731,800 B2 *	8/2023	Borst, Sr. .... B65D 5/42 229/152
5,803,345 A	9/1998	Jones et al.	11,840,379 B2	12/2023	Humberstone et al.
5,875,961 A	3/1999	Stone et al.	11,919,686 B1	3/2024	Jackson et al.
5,918,797 A	7/1999	Correll	11,939,121 B2	3/2024	Donschietz et al.
5,941,453 A	8/1999	Oliff	11,945,627 B2	4/2024	Borst, Sr. et al.
D432,912 S	10/2000	Lubineau-Bigot et al.	11,993,428 B2	5/2024	Mayer
D433,630 S	11/2000	Lubineau-Bigot et al.	D1,032,358 S	6/2024	Walters et al.
6,206,277 B1	3/2001	Correll	D1,037,847 S	8/2024	Borst, Sr. et al.
6,223,979 B1	5/2001	Correll	2003/0163978 A1	9/2003	Correll
6,290,122 B1	9/2001	Correll	2005/0103832 A1	5/2005	Correll
D449,520 S	10/2001	Dizoglio, III	2009/0057387 A1	3/2009	Tirado Alanis
6,364,199 B1	4/2002	Rose	2011/0136641 A1	6/2011	Lee et al.
6,401,971 B1	6/2002	Edwards et al.	2012/0234904 A1	9/2012	Costanzo, Jr.
6,685,085 B2	2/2004	Hanna	2016/0001937 A1	1/2016	Skinner
6,868,964 B2	3/2005	Carty et al.	2016/0107785 A1	4/2016	Sato et al.
6,889,891 B2	5/2005	Correll	2016/0194111 A1	7/2016	Sharon et al.
6,922,976 B2	8/2005	Correll	2017/0202401 A1	7/2017	Mortell
6,997,372 B2	2/2006	Gasparowicz	2017/0297802 A1	10/2017	Davis et al.
D569,719 S	5/2008	Ross	2017/0297803 A1	10/2017	Chambers et al.
D592,968 S	5/2009	Lee et al.	2017/0313464 A1	11/2017	McCarthy et al.
7,578,393 B2	8/2009	Gillon	2017/0362008 A1	12/2017	Theodorakos
D601,419 S	10/2009	Sant'et al.	2018/0170610 A1	6/2018	Buss
D613,153 S *	4/2010	Russell ..... D9/423	2019/0100346 A1	4/2019	Bressan et al.
D628,065 S *	11/2010	Russell ..... D9/434	2019/0248536 A1	8/2019	Foushee
D649,040 S	11/2011	Sanders	2019/0300224 A1	10/2019	Jiang et al.
8,162,206 B2	4/2012	Harrelson	2019/0344927 A1	11/2019	Ozgercel
8,408,451 B2	4/2013	Adam et al.	2020/0391903 A1	12/2020	Donschietz et al.
D696,107 S	12/2013	Kimple et al.	2021/0078755 A1	3/2021	Sollie et al.
			2021/0371153 A1	12/2021	Borst, Sr. et al.
			2022/0017263 A1	1/2022	Wikstrom
			2022/0055794 A1	2/2022	Humberstone et al.

(56)

## References Cited

## U.S. PATENT DOCUMENTS

2022/0289423	A1	9/2022	Borst, Sr. et al.	
2023/0249869	A1*	8/2023	Ball .....	B65D 5/301 206/299
2023/0249897	A1	8/2023	Forsberg	
2023/0312159	A1	10/2023	Borst, Sr. et al.	
2023/0312164	A1	10/2023	Humberstone et al.	
2023/0312165	A1	10/2023	Humberstone et al.	
2023/0312218	A1	10/2023	Wu et al.	
2023/0331430	A1	10/2023	Valance	

## FOREIGN PATENT DOCUMENTS

EP	0936152	12/2003
EP	1992574	11/2008
FR	2504892	11/1982
GB	472474	9/1937
GB	2227731	8/1990
GB	2305653	4/1997
GB	2328201	2/1999
GB	2456838	7/2009
KR	301122910.0000	8/2021
WO	2013007306	1/2013

## OTHER PUBLICATIONS

Cardboard box: Announced [Apr. 20, 2013; online]. Retrieved [Jun. 16, 2023]. URL: <https://www.dreamstime.com/royalty-free-stock-image-cardboard-box-image21861166> (Year: 2013).\*

Pizza Pizza: Announced [Date Not Available; online]. Retrieved [Jun. 16, 2023]. URL: <https://markets.businessinsider.com/news/stocks/pizza-pizza-delivers-peace-of-mind-with-new-tamper-proof-pizza-box-1029075812> (Year: 2023).\*

Versacube: Announced [Oct. 28, 2021; online]. Retrieved [Jun. 16, 2023]. URL: <https://www.oberk.com/containers/plastic/plastic-jug/58240009--5gallon-natural-hdpe-versacube-generic-carton-square---38-400-te-neck> (Year: 2021).\*

Borst Sr., Kendrick Michael; Notice of Allowance for U.S. Appl. No. 16/915,556, filed Jun. 29, 2020, mailed Feb. 3, 2022, 13 pgs. shpkg.com; Article entitled: "Single Layer Corrugated Box", available at <https://www.shpkg.com/product/Kraft-Sealing-Box-For-Cosmetic.html>, accessed on Sep. 16, 2021, 15 pgs.

Borst Sr., Kendrick Michael; Notice of Allowance for U.S. Appl. No. 16/915,556, filed Jun. 29, 2020, mailed Mar. 3, 2022, 10 pgs. Humberstone, Robert F.; Non-Final Office Action for U.S. Appl. No. 17/001,016, filed Aug. 24, 2020, mailed May 6, 2022, 31 pgs.

Humberstone, Robert F.; Requirement for Restriction/Election for U.S. Appl. No. 17/001,016, filed Aug. 24, 2020, mailed Feb. 23, 2022, 6 pgs.

Borst Jr., Kendrick Michael; Applicant-Initiated Interview Summary for U.S. Appl. No. 17/830,020, filed Jun. 1, 2022, mailed Feb. 21, 2023, 2 pgs.

Borst Sr., Kendrick Michael; Notice of Allowance for U.S. Appl. No. 17/830,020, filed Jun. 1, 2022, mailed Mar. 9, 2023, 9 pgs.

Humberstone, Robert F.; Notice of Allowance for U.S. Appl. No. 17/001,016, filed Aug. 24, 2020, mailed Mar. 6, 2023, 12 pgs. trendhunter.com; Article entitled: "Tamper-Proof Pizza Boxes", located at <https://www.trendhunter.com/trends/tamper-proof-pizza-box>, accessed on May 11, 2020, 6 pgs.

locktheboxes.com; Article entitled: "Lock the Boxes", accessed on May 11, 2020, 6 pgs.

PizzaLoc; Article entitled: "PizzaLoc tamper-evident fastener", located at <https://www.pizzaloc.com/>, publicly available prior to May 28, 2020, 6 pgs.

Borst Sr., Kendrick Michael; Applicant-Initiated Interview Summary for U.S. Appl. No. 16/915,556, filed Jun. 29, 2020, mailed Aug. 30, 2021, 2 pgs.

Borst Sr., Kendrick Michael; Certificate of Correction for U.S. Appl. No. 16/915,556, filed Jun. 29, 2020, mailed Dec. 20, 2022, 1 pg.

Borst Sr., Kendrick Michael; Non-Final Office Action for U.S. Appl. No. 17/830,020, filed Jun. 1, 2022, mailed Nov. 28, 2022, 18 pgs. Humberstone, Robert F.; Final Office Action for U.S. Appl. No. 17/001,016, filed Aug. 24, 2020, mailed Nov. 15, 2022, 14 pgs.

Borst Sr., Kendrick Michael; Non-Final Office Action for U.S. Appl. No. 16/915,556, filed Jun. 29, 2020, mailed Jun. 30, 2021, 13 pgs. Borst, Sr., Kendrick Michael; Requirement for Restriction/Election for U.S. Appl. No. 16/915,556, filed Jun. 29, 2020, mailed May 4, 2021, 6 pgs.

Humberstone, Robert F.; Applicant-Initiated Interview Summary for U.S. Appl. No. 17/001,016, filed Aug. 24, 2020, mailed Jul. 12, 2022, 2 pgs.

Borst Sr., Kendrick Michael; Non-Final Office Action for Design U.S. Appl. No. 29/749,665, filed Sep. 8, 2020, mailed Jun. 15, 2023, 53 pgs.

Borst Sr., Kendrick Michael; Applicant-Initiated Interview Summary for Design U.S. Appl. No. 29/749,665, filed Sep. 8, 2020, mailed Sep. 28, 2023, 3 pgs.

Avi Diti Mailer Box, posted at Amazon.com on Jul. 22, 2010, [site visited Sep. 7, 2023]. Available from internet, URL: <https://www.amazon.com/dp/BOOBT5L TTG/> (Year: 2010), 1 pg.

Ball, Randy; Non-Final Office Action for Design U.S. Appl. No. 29/825,994, filed Feb. 8, 2022, mailed Oct. 6, 2023, 45 pgs.

Borst Sr., Kendrick Michael; Non-Final Office Action for U.S. Appl. No. 18/207,080, filed Jun. 7, 2023, mailed Dec. 15, 2023, 32 pgs.

Borst Sr., Kendrick Michael; Notice of Allowance for U.S. Appl. No. 18/207,080, filed Jun. 7, 2023, mailed Jan. 25, 2024, 5 pgs.

Humberstone, Robert F.; Non-Final Office Action for U.S. Appl. No. 18/205,401, filed Jun. 2, 2023, mailed Dec. 7, 2023, 31 pgs.

Humberstone, Robert F.; Non-Final Office Action for U.S. Appl. No. 18/205,403, filed Jun. 2, 2023, mailed Dec. 7, 2023, 29 pgs.

Borst Sr., Kendrick Michael; Final Office Action for Design U.S. Appl. No. 29/749,665, filed Sep. 8, 2020, mailed Dec. 12, 2023, 15 pgs.

Humberstone, Robert F.; Notice of Allowance for U.S. Appl. No. 18/205,401, filed Jun. 2, 2023, mailed Mar. 22, 2024, 9 pgs.

Humberstone, Robert F.; Notice of Allowance for U.S. Appl. No. 18/205,403, filed Jun. 2, 2023, mailed Mar. 22, 2024, 9 pgs.

Ball, Randy; Requirement for Restriction/Election for U.S. Appl. No. 17/667,199, filed Feb. 8, 2022, mailed Apr. 30, 2024, 6 pgs.

Borst Sr., Kendrick Michael; Notice of Allowance for U.S. Appl. No. 29/749,665, filed Sep. 8, 2020, mailed Mar. 21, 2024, 11 pgs.

Ball, Randy; Notice of Allowance for Design U.S. Appl. No. 29/825,994, filed Feb. 8, 2022, mailed Feb. 26, 2024, 10 pgs.

Humberstone, Robert F.; Notice of Allowance for U.S. Appl. No. 18/205,401, filed Jun. 2, 2023, mailed Aug. 13, 2024, 5 pgs.

Humberstone, Robert F.; Notice of Allowance for U.S. Appl. No. 18/205,403, filed Jun. 2, 2023, mailed Aug. 14, 2024, 5 pgs.

Ball, Randy; Notice of Allowance for Design U.S. Appl. No. 29/825,994, filed Feb. 8, 2022, mailed Sep. 17, 2024, 11 pgs.

amazon.com; Article entitled: Fairlegend Self Sealing Small Corrugated Cardboard Shipping Boxes Mailers 4x3x2 Mailer Boxes for Small Businesses, posted at Amazon.com on Feb. 5, 2021, Available from internet, URL: <https://www.amazon.com/Cardboard-Mailer-Self-Sealing-Shipping-Tear-Off/dp/B08VN GJ BCG/> (Year: 2021), 2 pgs.

amazon.com; Article entitled: Aviditi Brown Kraft Literature Mailing Boxes, 11 1-8 x 8 3/4 x 4 Inches, Pack of 50, Crush Proof, for Shipping, Mailing, and Storing, posted at Amazon.com on Jul. 22, 2010, 2 pgs.

Ball, Randy; Notice of Allowance for Design U.S. Appl. No. 29/943,344, filed May 21, 2024, mailed Jul. 3, 2024, 8 pgs.

Borst Sr., Kendrick Michael; Certificate of Correction for U.S. Appl. No. 17/830,020, filed Jun. 1, 2022, mailed Oct. 15, 2024, 5 pgs.

Ball, Randy; Non-Final Office Action for U.S. Appl. No. 17/667,199, filed Feb. 8, 2022, mailed Oct. 8, 2024, 64 pgs.

Borst Sr., Kendrick Michael; Ex Parte Quayle Action for Design U.S. Appl. No. 29/947,936, filed Jun. 18, 2024, mailed Sep. 30, 2024, 29 pgs.

Boxes Fast Corrugated Cardboard Mailers, posted at Amazon.com on Dec. 12, 2017, [site visited Sep. 7, 2024]. Available from internet, URL: <https://www.amazon.com/Boxes-Fast-BFMLRCD-Corrugated-Cardboard/dp/B0786LQMYL/> (Year: 2017), 2 pgs.

(56)

**References Cited**

OTHER PUBLICATIONS

Ireer Pizza Box, posted at Amazon.com on Aug. 16, 2023, [site visited Sep. 7, 2024]. Available from internet, URL: <<https://www.amazon.com/Ireer-Corrugated-Cardboard-Takeaway-Shipping/dp/BOCFPTLWB/>> (Year: 2023), 2 pgs.

\* cited by examiner

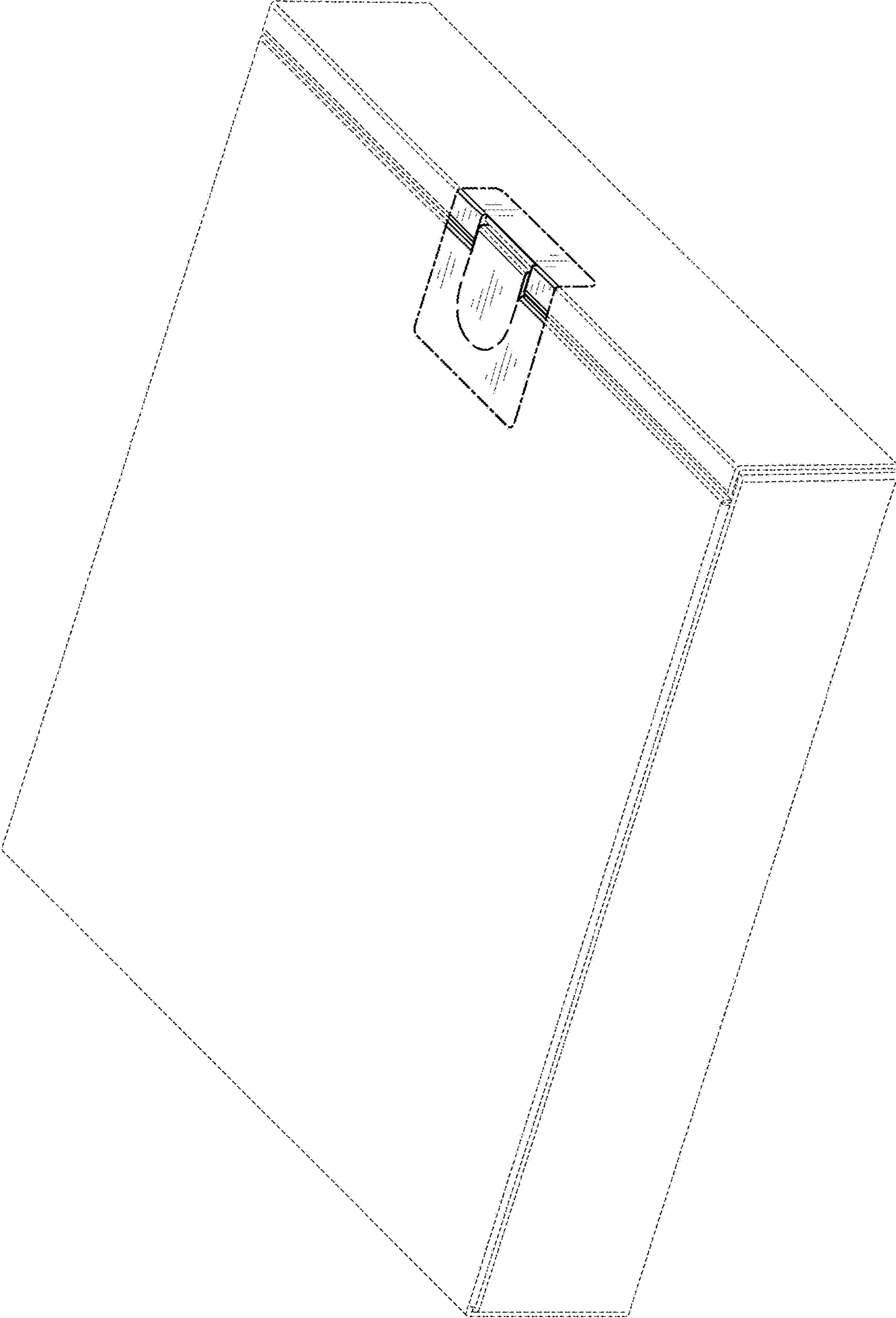
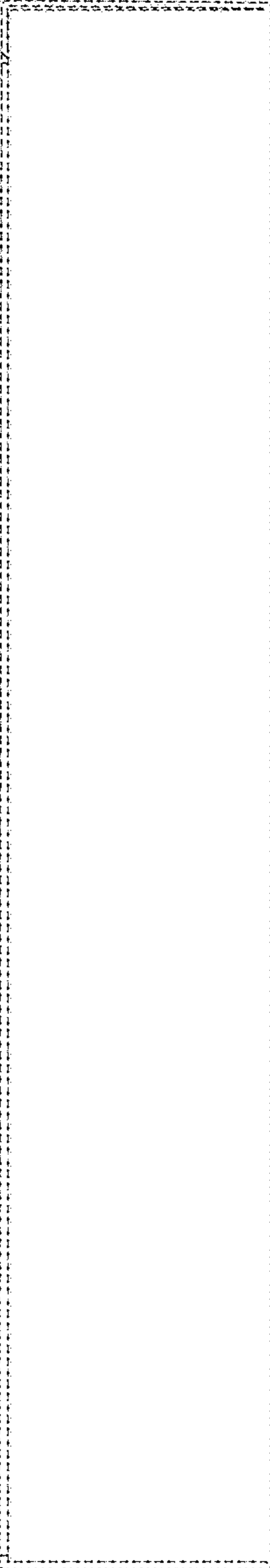
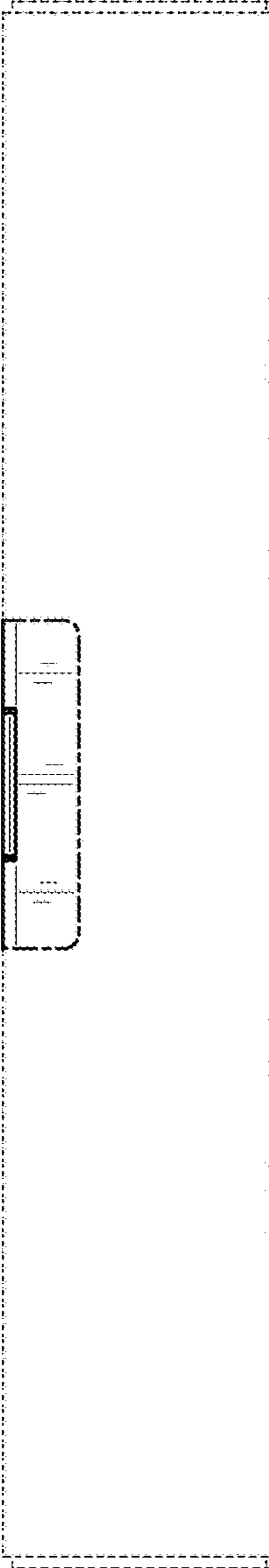

FIG. 1



**FIG. 2**



**FIG. 3**

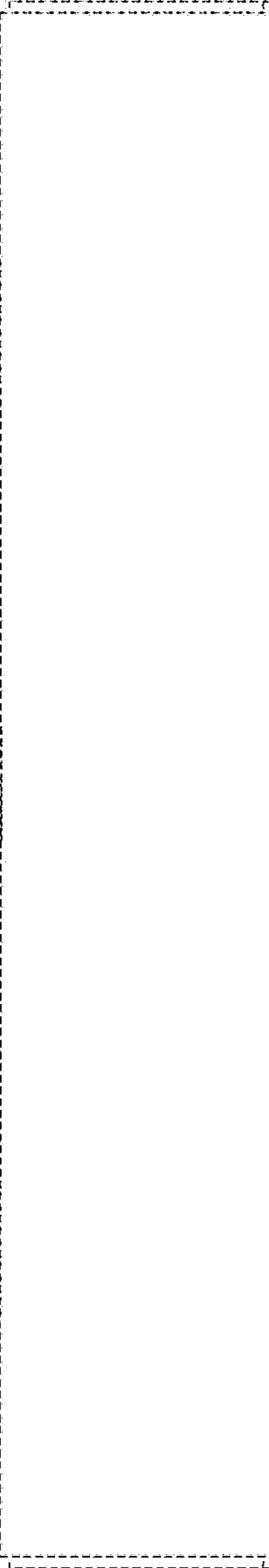

**FIG. 4**

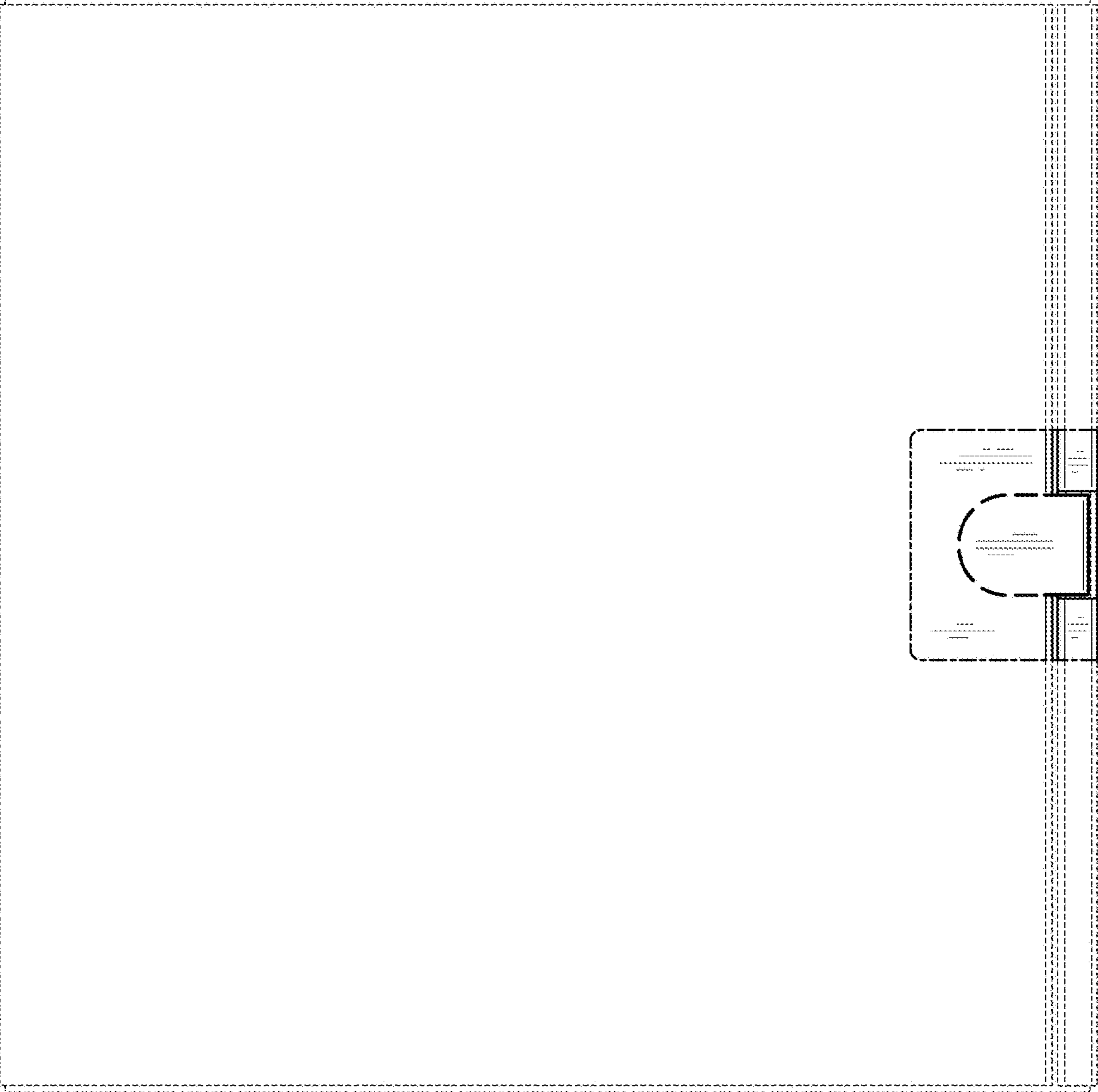
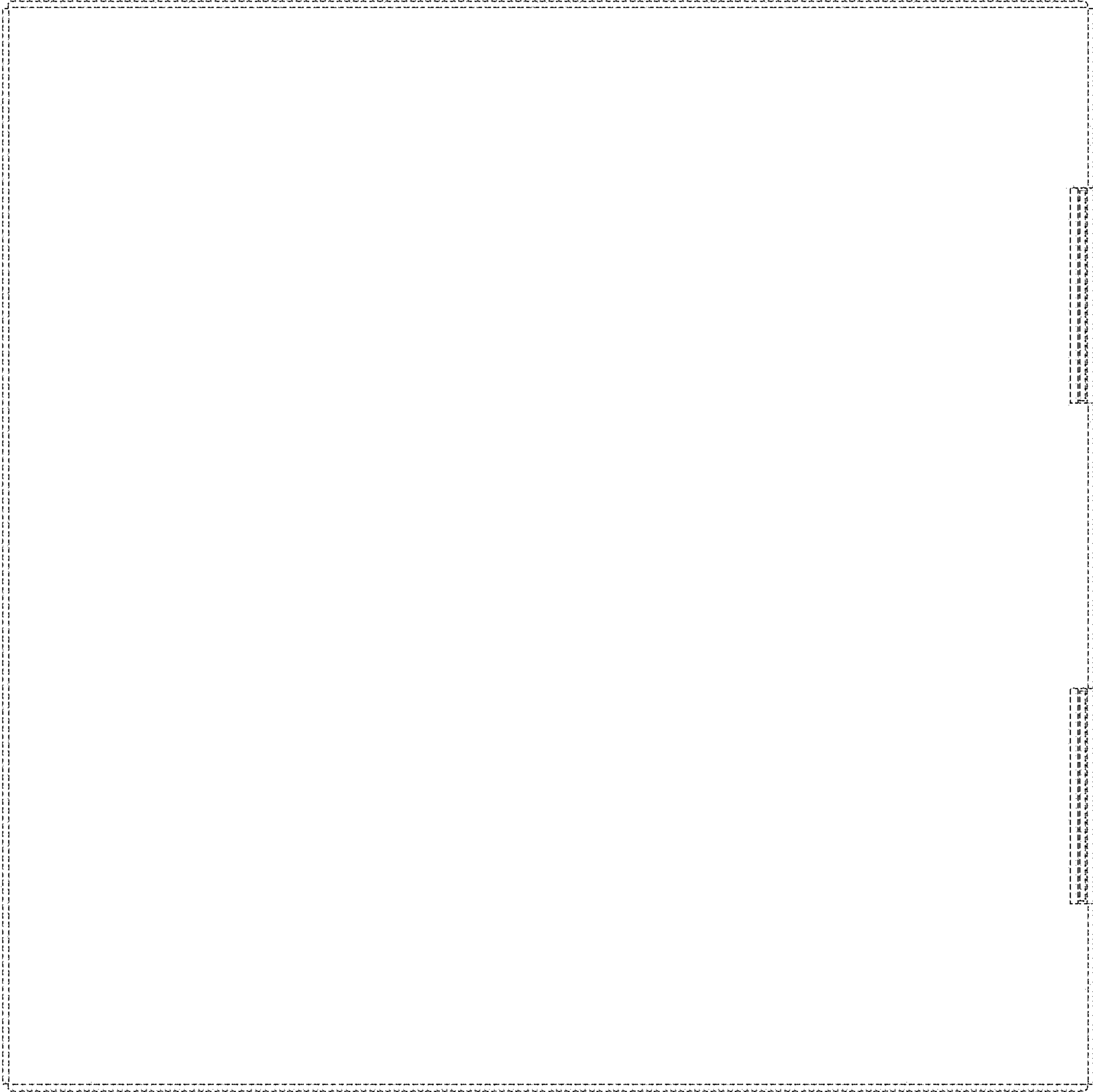

FIG. 5



**FIG. 6**



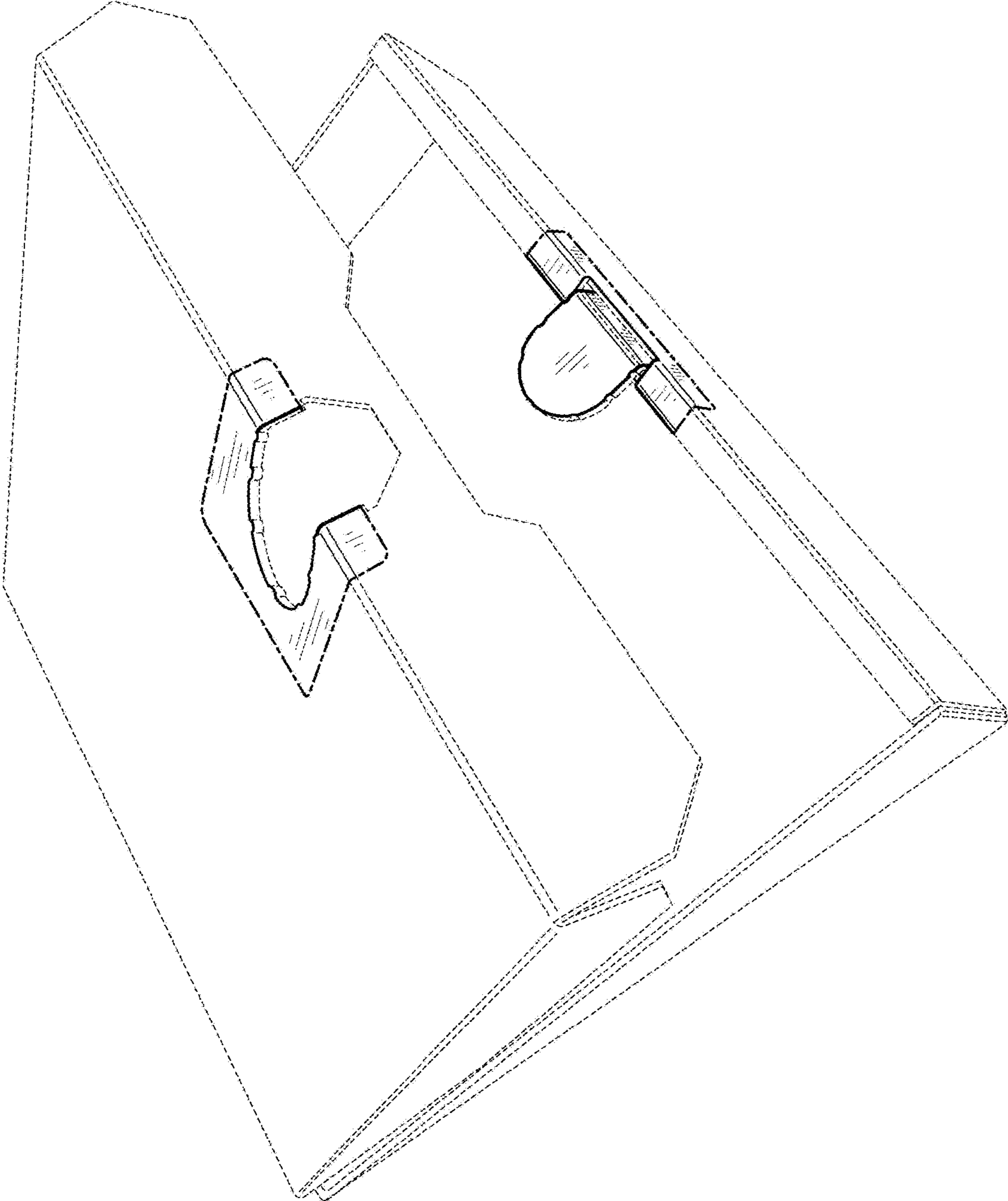

FIG. 7

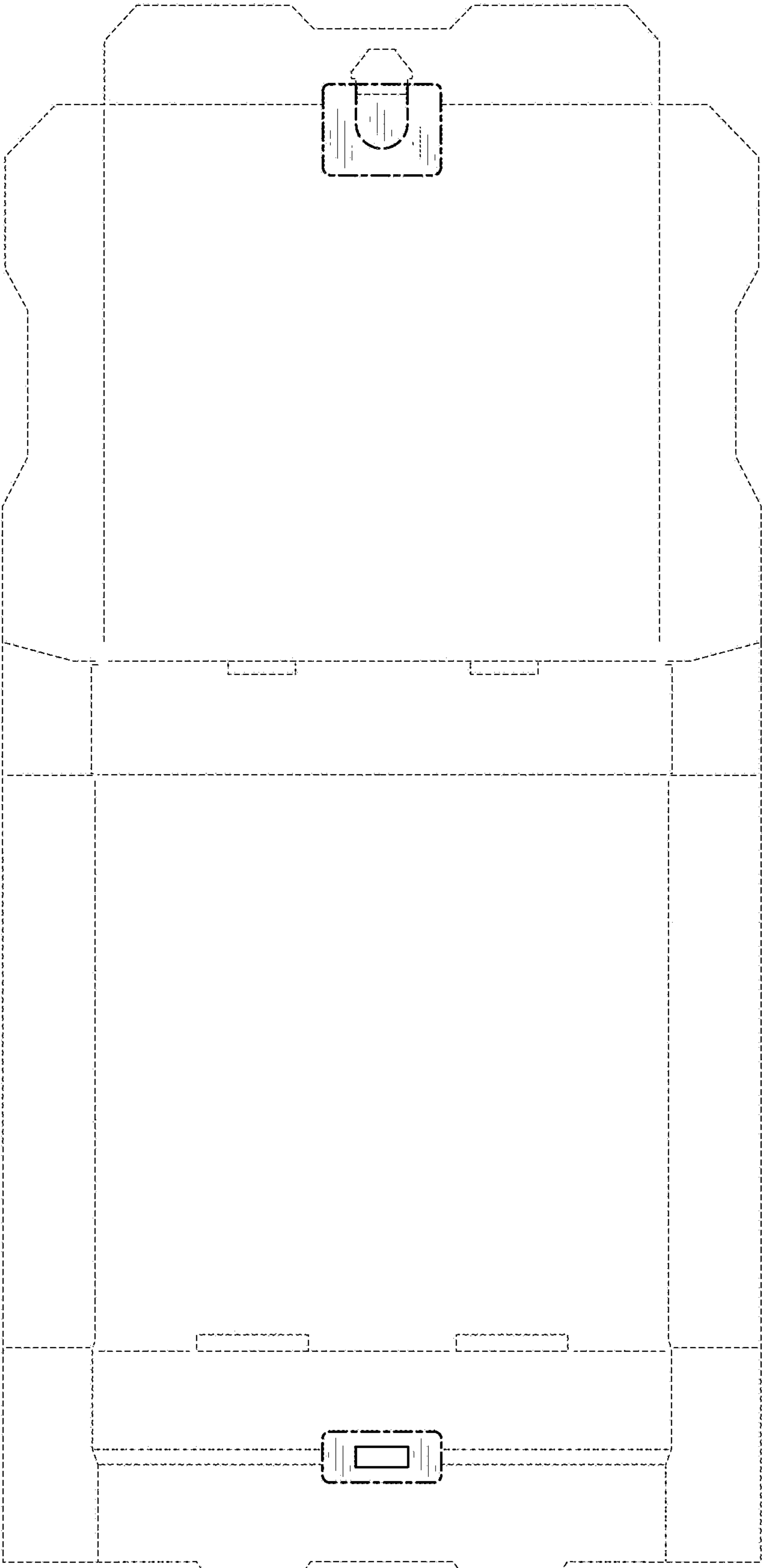

FIG. 8