



US0D1039655S

(12) **United States Design Patent** (10) **Patent No.:** **US D1,039,655 S**  
**Xie** (45) **Date of Patent:** **\*\* Aug. 20, 2024**

(54) **HIGH PRESSURE WATER GUN**  
(71) Applicant: **Jinchun Xie**, Zhejiang (CN)  
(72) Inventor: **Jinchun Xie**, Zhejiang (CN)  
(\*\*) Term: **15 Years**

(21) Appl. No.: **29/811,838**  
(22) Filed: **Oct. 18, 2021**  
(51) **LOC (14) Cl.** ..... **23-01**  
(52) **U.S. Cl.**  
USPC ..... **D23/226**  
(58) **Field of Classification Search**  
USPC ..... D23/200, 213, 223, 226, 229, 235  
CPC .. B05B 9/01; B05B 9/03; B05B 12/00; B05B  
12/0026; B08B 3/026; B08B 3/028; B08B  
2203/0282  
See application file for complete search history.

(56) **References Cited**

**U.S. PATENT DOCUMENTS**

4,541,568	A *	9/1985	Lichfield	.....	B60S 3/044
					239/441
D291,113	S *	7/1987	Bauer	.....	D32/25
D303,139	S *	8/1989	Morgan	.....	D23/223
D346,647	S *	5/1994	Arnette	.....	D23/225
D376,838	S *	12/1996	Potts	.....	D23/223
D499,791	S *	12/2004	Etter	.....	D23/226
D501,536	S *	2/2005	Amaduzzi	.....	D23/226
D518,873	S *	4/2006	Carpanese	.....	D23/223
D555,767	S *	11/2007	Carpanese	.....	D23/226
D571,434	S *	6/2008	Renner	.....	D23/223
7,516,910	B1 *	4/2009	DeWall	.....	B05B 12/0026
					239/525
D636,846	S *	4/2011	Shoemaker	.....	D23/213
D768,263	S *	10/2016	Laber	.....	D23/226
D769,413	S *	10/2016	Liao	.....	D23/223
D770,015	S *	10/2016	Wright	.....	D23/223
D850,582	S *	6/2019	Weinberg	.....	D23/223
D910,145	S *	2/2021	Roehl	.....	D23/213
D910,812	S *	2/2021	Kangkang	.....	D23/226

D942,588	S *	2/2022	Alexander	.....	D23/226
D965,745	S *	10/2022	Lin	.....	D23/226
D969,272	S *	11/2022	Lin	.....	D23/226
D974,528	S *	1/2023	Fang	.....	D23/226
D1,003,393	S *	10/2023	Zheng	.....	D23/226
D1,003,394	S *	10/2023	Zheng	.....	D23/226

(Continued)

**FOREIGN PATENT DOCUMENTS**

EM 008729818 \* 10/2021

**OTHER PUBLICATIONS**

Sooprinse High Pressure Washer Gun. Amazon Standard ID# B0B45X9HGQ. Catalogue [Online]. Amazon.com 2022. [Date First Available: Jun. 15, 2022][Retrieved on Oct. 28, 2023]. Retrieved from the Internet: <URL:https://www.amazon.com/Sooprinse-Pressure-Replacement-Extension-Fitting/dp/B0B45X9HGQ> (Year: 2022).\*

*Primary Examiner* — Janice Hallmark  
*Assistant Examiner* — Adedoyin Taiwo Odeyale

(57) **CLAIM**

The ornamental design for a high pressure water gun, as shown and described.

**DESCRIPTION**

FIG. 1 is a perspective view of a high pressure water gun showing my new design;  
FIG. 2 is a front elevational view thereof;  
FIG. 3 is a rear elevational view thereof;  
FIG. 4 is an enlarged left side elevational view thereof;  
FIG. 5 is an enlarged right side elevational view thereof;  
FIG. 6 is a top plan view thereof; and,  
FIG. 7 is a bottom plan view thereof.  
The broken lines throughout the drawing figures depict portions of the high pressure water gun that form no part of the claimed design.

**1 Claim, 7 Drawing Sheets**

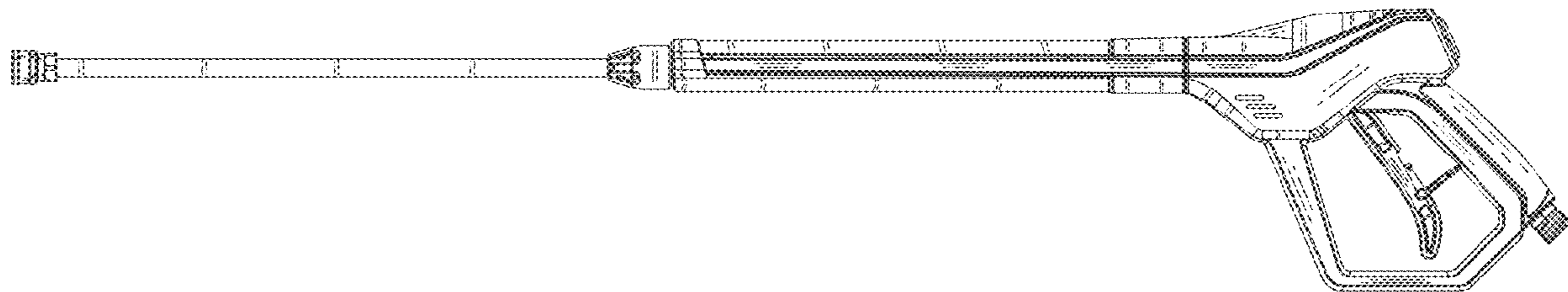

(56)

**References Cited**

U.S. PATENT DOCUMENTS

2006/0131151 A1\* 6/2006 Marchand ..... B05B 12/0026  
200/336  
2015/0174598 A1\* 6/2015 Eschrich ..... B05B 9/01  
239/526  
2022/0339648 A1\* 10/2022 Cigarini ..... B05B 12/0026  
2022/0339649 A1\* 10/2022 Cigarini ..... B05B 9/01

\* cited by examiner

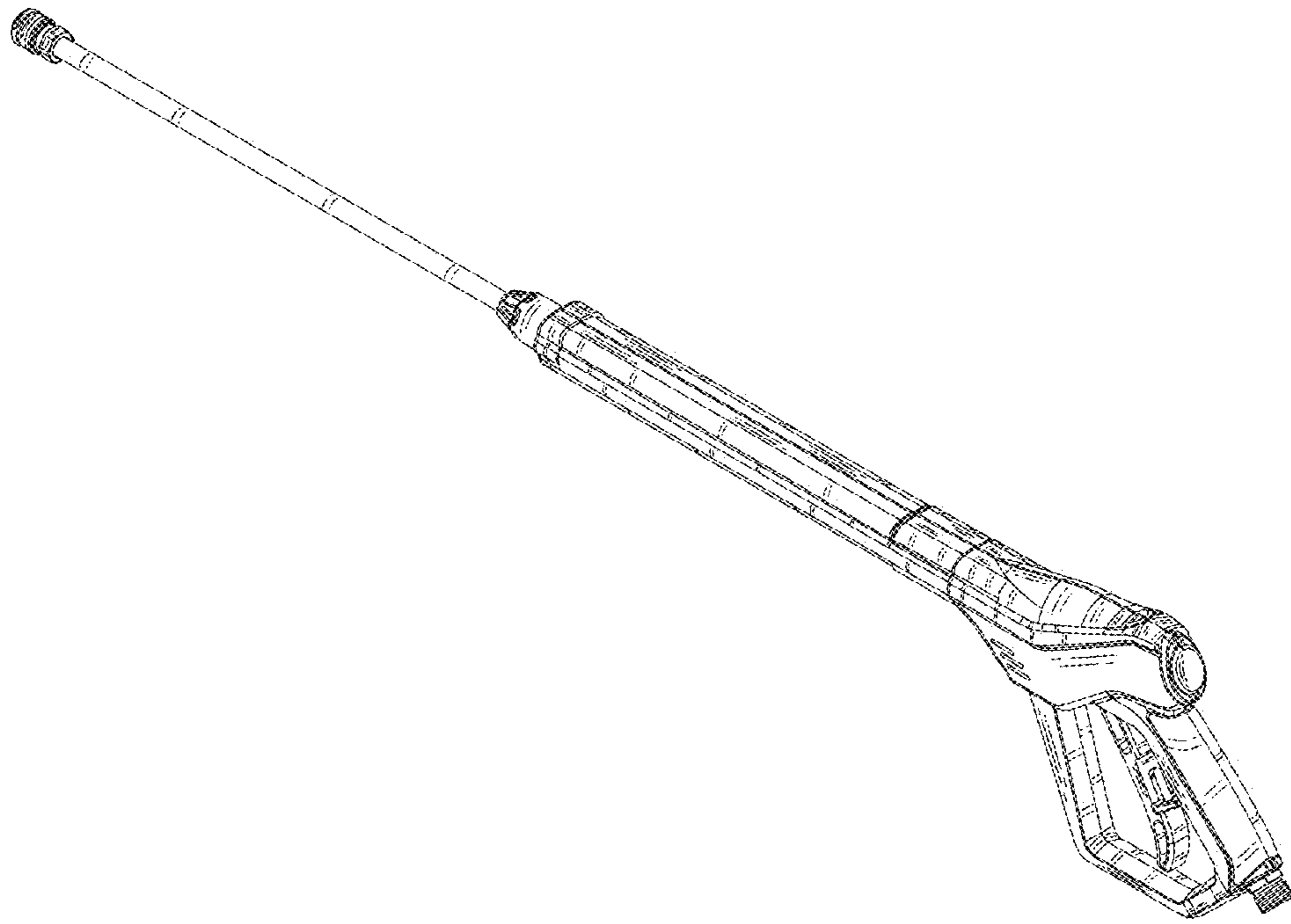

FIG.1

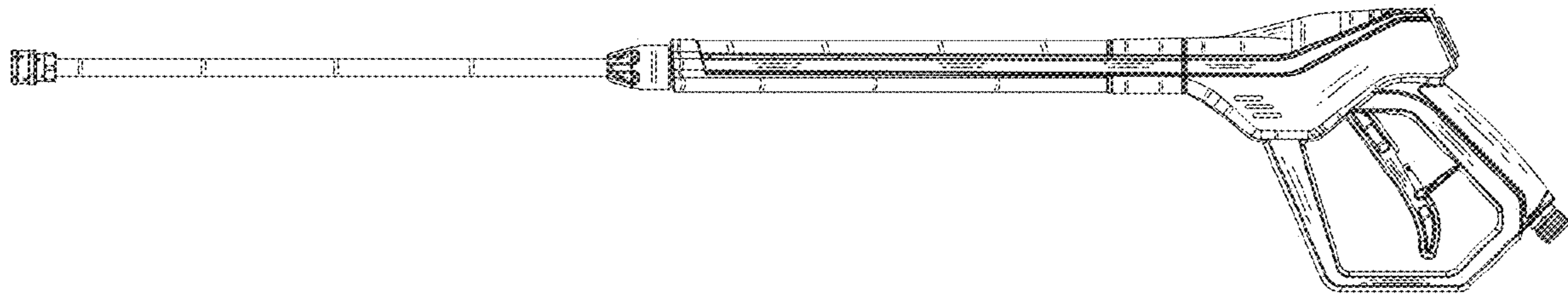

FIG.2

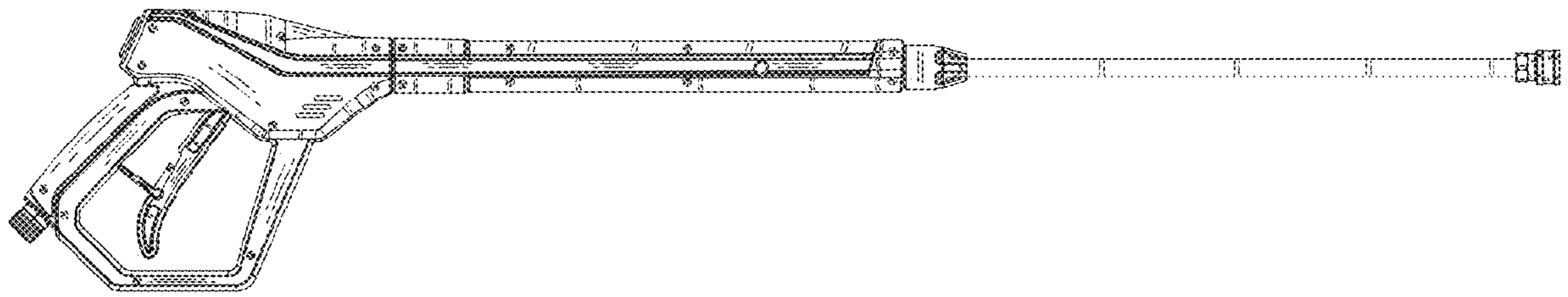

FIG.3

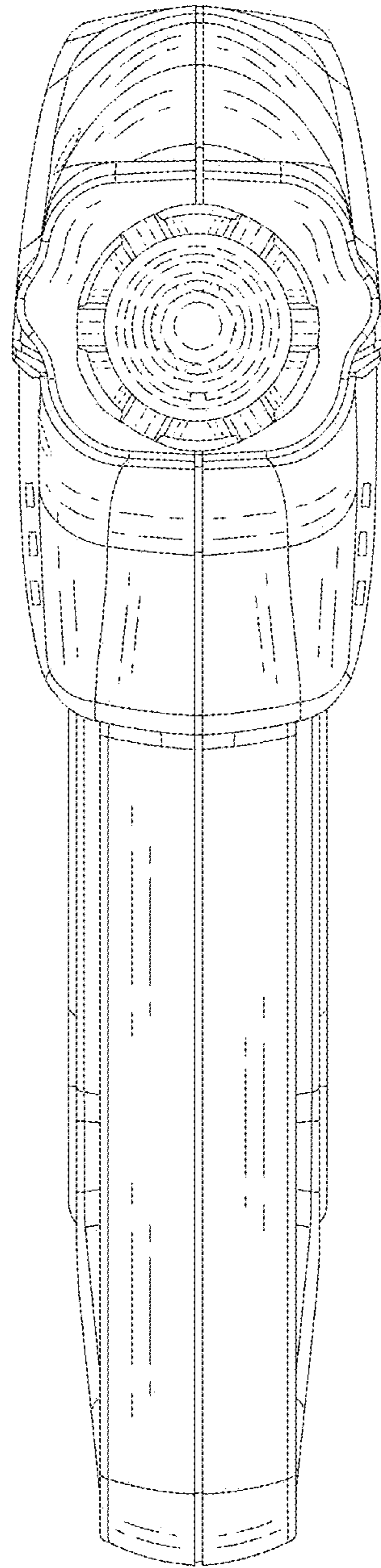

FIG.4

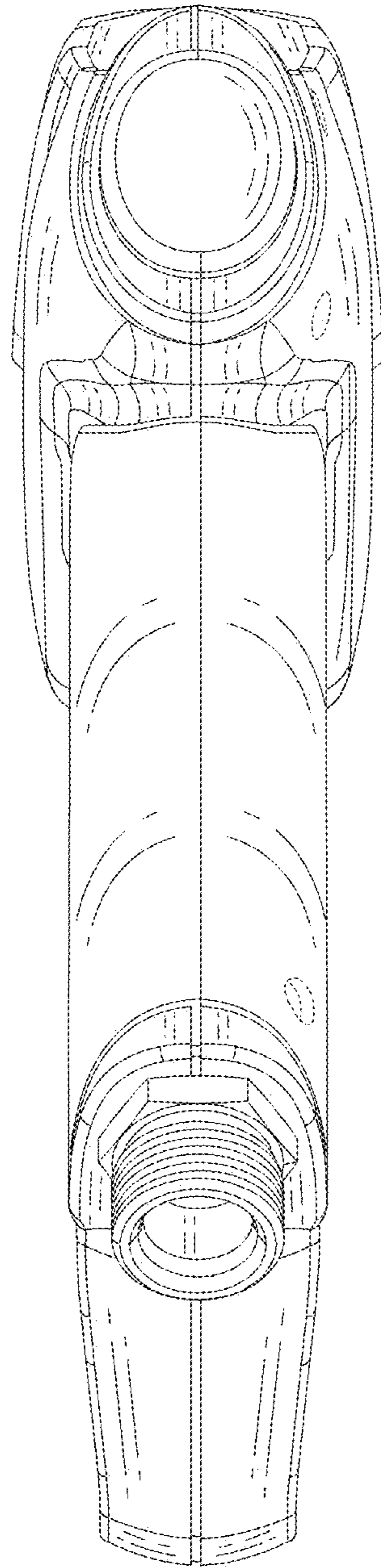

FIG.5

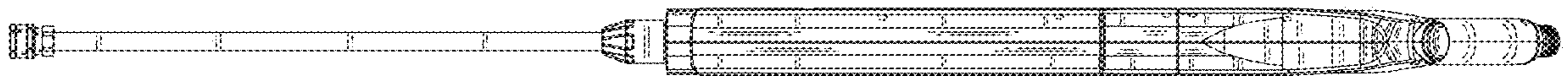

FIG.6



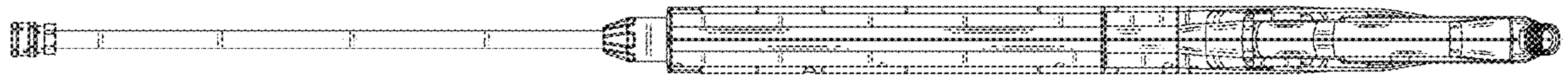

FIG.7