



US0D1039134S

(12) **United States Design Patent** (10) **Patent No.:** **US D1,039,134 S**
McDermott et al. (45) **Date of Patent:** **** Aug. 13, 2024**

(54) **TUBE ASSEMBLY AND CONNECTOR**

FOREIGN PATENT DOCUMENTS

(71) Applicant: **Fisher & Paykel Healthcare Limited**,
Auckland (NZ)

CN 2652420 Y 11/2004
CN 101365509 2/2009

(Continued)

(72) Inventors: **Gareth Thomas McDermott**, Auckland
(NZ); **Jaiden Gray Walmsley**,
Auckland (NZ); **Craig Karl White**,
Auckland (NZ); **Alicia Jerram Hunter**
Evans, Walmsley (NZ)

OTHER PUBLICATIONS

Coupling Insert, In-Line Hose Barb, Thomas Scientific, [Post date:
unknown], [Site seen Nov. 21, 2023], Seen at URL: https://www.thomassci.com/Laboratory-Supplies/Tubing-Connectors/_/Coupling-Insert-In-Line-Hose-Barb-Straight-Thru2 (Year: 2023).*

(Continued)

(73) Assignee: **Fisher & Paykel Healthcare Limited**,
Auckland (NZ)

(**) Term: **15 Years**

Primary Examiner — Natasha Vujcic

Assistant Examiner — Gilbert B Ford

(21) Appl. No.: **29/879,044**

(74) *Attorney, Agent, or Firm* — Knobbe, Martens, Olson
& Bear, LLP

(22) Filed: **Jun. 30, 2023**

(57) **CLAIM**

The ornamental design for a tube assembly and connector, as
shown and described.

Related U.S. Application Data

DESCRIPTION

(62) Division of application No. 29/788,503, filed on Jun.
11, 2021, now Pat. No. Des. 995,758.

(51) **LOC (14) Cl.** **29-02**

(52) **U.S. Cl.**
USPC **D24/110.4**; D24/129

(58) **Field of Classification Search**
USPC D24/127–131, 133, 186, 110,
D24/110.1–110.6, 113, 108
CPC A61M 16/0816; A61M 16/0875; A61M
39/105; A61M 2016/003; A61M
2039/1088

See application file for complete search history.

FIG. 1 is a front, right side and top perspective view of a tube
assembly and connector showing our new design.
FIG. 2 is a rear, left side and top perspective view thereof.
FIG. 3 is a top view thereof.
FIG. 4 is a bottom view thereof.
FIG. 5 is a right side view thereof.
FIG. 6 is a left side view thereof.
FIG. 7 is a front view thereof, enlarged for clarity; and,
FIG. 8 is a rear view thereof, enlarged for clarity.

The broken lines in the drawings illustrate portions of the
tube assembly and connector and form no part of the claimed
design.

The break lines in FIGS. 1-6 indicate that the appearance of
any portion of the tube assembly and connector between the
break lines forms no part of the claimed design.

(56) **References Cited**

U.S. PATENT DOCUMENTS

132,604 A 10/1872 Smith et al.
327,877 A 10/1885 Hodges

(Continued)

1 Claim, 7 Drawing Sheets

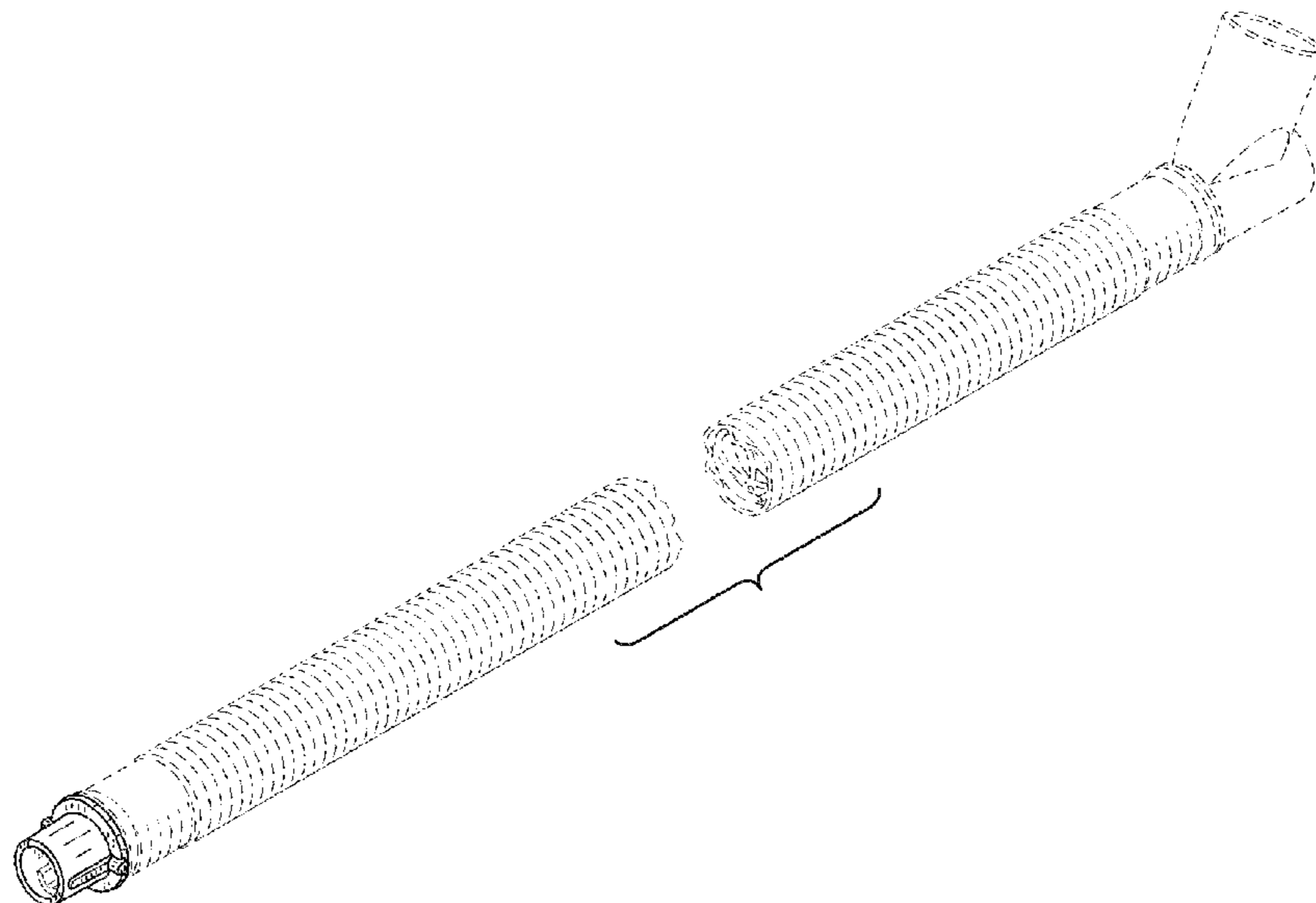

(56)

References Cited

U.S. PATENT DOCUMENTS

643,358 A 2/1900 Konold
 778,936 A 1/1905 Witmond
 1,080,674 A 12/1913 Berg
 1,130,726 A 3/1915 Greve
 1,194,793 A 8/1916 Styers
 1,673,338 A 6/1928 Mitchell
 1,880,098 A 9/1932 Mair
 1,916,449 A 7/1933 Tompkins
 2,124,474 A 7/1938 Scholtes
 2,479,580 A 8/1949 Marco
 2,727,759 A 12/1955 Elliott
 2,910,308 A 10/1959 Carr
 3,287,031 A 11/1966 Simmons et al.
 3,323,774 A 6/1967 Wilson
 3,513,844 A 5/1970 Smith
 3,601,361 A 8/1971 Hundhausen et al.
 3,813,115 A 5/1974 French
 3,815,754 A 6/1974 Rosenberg
 4,036,616 A 7/1977 Byrns
 4,111,514 A 9/1978 Brishka et al.
 4,128,407 A 12/1978 Chapel
 4,161,949 A 7/1979 Thanawalla
 4,211,439 A 7/1980 Moldestad
 D267,199 S 12/1982 Koenig
 4,386,948 A 6/1983 Choksi et al.
 4,443,028 A 4/1984 Hayes
 4,446,869 A 5/1984 Knodle
 4,584,997 A 4/1986 Delong
 4,589,684 A 5/1986 Nowacki et al.
 4,601,495 A 7/1986 Webb
 4,661,110 A 4/1987 Fortier et al.
 4,676,241 A 6/1987 Webb et al.
 4,758,023 A 7/1988 Vermillion
 4,773,448 A 9/1988 Francis
 D300,271 S 3/1989 Rudolph et al.
 D300,272 S 3/1989 Rudolph et al.
 D302,040 S 7/1989 Lambert et al.
 4,936,841 A 6/1990 Aoki et al.
 5,005,571 A 4/1991 Dietz
 5,009,252 A 5/1991 Faughn
 5,040,527 A 8/1991 Larson et al.
 5,064,226 A 11/1991 Klas
 D328,033 S 7/1992 DiGuseppi
 5,158,569 A 10/1992 Strickland et al.
 5,169,180 A * 12/1992 Villoni F16L 25/023
 285/148.13
 5,281,206 A 1/1994 Lopez
 5,335,656 A 8/1994 Bowe et al.
 D362,718 S 9/1995 Deily et al.
 D363,541 S 10/1995 Cottone, Sr. et al.
 5,456,676 A 10/1995 Nelson et al.
 5,529,284 A 6/1996 Berger et al.
 5,584,997 A 12/1996 Yagihashi et al.
 5,620,427 A 4/1997 Werschmidt et al.
 5,718,143 A 2/1998 Clowes
 5,725,258 A 3/1998 Kujawski
 5,725,511 A 3/1998 Urrutia
 5,735,271 A 4/1998 Lorenzen et al.
 5,738,142 A 4/1998 Eike et al.
 5,741,084 A 4/1998 Del Rio et al.
 D395,502 S 6/1998 Deily et al.
 5,901,705 A 5/1999 Leagre
 D424,687 S 5/2000 Hoenig et al.
 D427,308 S 6/2000 Zinger
 6,099,519 A 8/2000 Olsen
 D431,634 S 10/2000 Mantz
 D439,326 S 3/2001 Hecker et al.
 D443,863 S * 6/2001 Maccarone D13/155
 D449,107 S 10/2001 Madsen
 6,402,207 B1 6/2002 Segal et al.
 6,439,234 B1 8/2002 Curti et al.
 6,484,724 B1 11/2002 Sloan
 D466,607 S 12/2002 Cise
 D468,015 S 12/2002 Horppu
 D471,262 S 3/2003 Kozu

D472,316 S 3/2003 Douglas et al.
 D472,630 S 4/2003 Douglas et al.
 6,561,549 B1 5/2003 Moris et al.
 D476,232 S 6/2003 Maus et al.
 6,581,974 B1 6/2003 Ragner et al.
 6,803,496 B2 10/2004 Elder et al.
 6,893,055 B2 5/2005 Thomas et al.
 6,915,705 B1 7/2005 Truitt
 6,932,390 B1 8/2005 Gretz
 6,953,354 B2 10/2005 Edirisuriya
 7,007,694 B2 3/2006 Aylsworth et al.
 D522,109 S * 5/2006 White D23/262
 D522,360 S 6/2006 Caserta
 7,201,167 B2 4/2007 Fink et al.
 D543,620 S 5/2007 Chu et al.
 D547,657 S 7/2007 Tacchella
 D551,340 S 9/2007 Wood et al.
 7,263,994 B2 9/2007 Gradon et al.
 7,267,121 B2 9/2007 Ivri
 D553,005 S 10/2007 Py
 7,290,541 B2 11/2007 Ivri et al.
 D556,899 S 12/2007 Veliss et al.
 D557,414 S 12/2007 Wentling
 7,306,121 B2 12/2007 Ophardt
 7,311,752 B2 12/2007 Tepper
 D565,731 S 4/2008 Eisenkolb et al.
 D570,457 S 6/2008 Brown
 7,406,966 B2 8/2008 Wondka
 7,458,615 B2 12/2008 White et al.
 D586,907 S 2/2009 Judson
 D586,911 S 2/2009 McAuley et al.
 7,484,769 B2 2/2009 Domash et al.
 D600,343 S 9/2009 Degabriele et al.
 D606,494 S 12/2009 Holliday
 D609,091 S 2/2010 Dubach
 7,666,170 B2 2/2010 Guala
 D612,481 S 3/2010 Reid et al.
 7,785,300 B2 8/2010 Ishii et al.
 D627,059 S 11/2010 Wood et al.
 D630,732 S 1/2011 Lev et al.
 D631,542 S 1/2011 DeGross
 7,874,596 B2 1/2011 Kertesz et al.
 D637,713 S 5/2011 Nord et al.
 7,946,291 B2 5/2011 Fink et al.
 D645,547 S 9/2011 Lombardi et al.
 8,020,551 B2 9/2011 Virr et al.
 8,092,409 B2 1/2012 Mros et al.
 D654,573 S 2/2012 Lombardi et al.
 D656,231 S 3/2012 Henry et al.
 8,186,352 B2 5/2012 Gunaratnam et al.
 D661,785 S 6/2012 Johnson
 8,256,459 B2 9/2012 Tesluk et al.
 8,257,286 B2 9/2012 Meyer et al.
 8,287,517 B2 10/2012 Hanlon et al.
 8,317,203 B2 11/2012 Hermle et al.
 D672,037 S 12/2012 Miller
 8,376,412 B2 2/2013 Johnson
 8,397,727 B2 3/2013 Ng et al.
 D682,415 S 5/2013 Mogensen et al.
 8,439,039 B2 5/2013 Gunaratnam et al.
 D685,463 S 7/2013 Veliss et al.
 8,485,193 B2 7/2013 Worley
 8,534,278 B2 9/2013 Colman et al.
 D691,712 S 10/2013 Judson et al.
 D691,717 S 10/2013 McLean et al.
 D692,555 S 10/2013 Maksym et al.
 D695,890 S 12/2013 Bowden et al.
 D697,200 S 1/2014 Mahaffy
 D698,440 S 1/2014 Lombardi, III
 8,622,057 B2 1/2014 Ujhazy et al.
 D707,355 S 6/2014 Bow
 8,741,220 B2 6/2014 O'Donnell et al.
 D709,996 S * 7/2014 Yu D23/262
 D710,695 S 8/2014 Pritikin
 8,814,849 B1 8/2014 Winsor
 8,870,238 B2 10/2014 Robert et al.
 D717,942 S 11/2014 Neff et al.
 D719,650 S * 12/2014 Arinobe D24/130
 8,960,727 B2 2/2015 Kendrick

(56)

References Cited

U.S. PATENT DOCUMENTS

D724,720 S	3/2015	O'Connor et al.	D849,931 S	5/2019	Prentice	
8,967,144 B2	3/2015	Lurie	D852,356 S *	6/2019	Steele	D24/129
D726,287 S	4/2015	Steele	10,322,254 B2	6/2019	Fong et al.	
D727,492 S	4/2015	Scampoli	D852,949 S	7/2019	Klenner et al.	
9,010,330 B2	4/2015	Barlow et al.	10,335,583 B2	7/2019	Gulliver et al.	
D732,664 S *	6/2015	Woehr	D855,794 S	8/2019	Gray	
D735,038 S	7/2015	Tamarindo	D856,510 S	8/2019	Scheirlinck	
D735,326 S	7/2015	Gulliver	D857,880 S	8/2019	Lau et al.	
D736,906 S	8/2015	Schultz	D860,445 S	9/2019	Ho	
D736,914 S	8/2015	Schultz	D861,162 S	9/2019	Gulliver et al.	
D737,953 S *	9/2015	Wells	D863,545 S	10/2019	Dantanarayana	
D737,963 S	9/2015	Srinivasan et al.	10,449,320 B2	10/2019	Miller	
9,132,252 B2	9/2015	Barlow et al.	D867,583 S	11/2019	Yang et al.	
9,188,267 B2	11/2015	Fansler et al.	D867,586 S	11/2019	Kemps	
D746,416 S	12/2015	Barlar	D867,587 S	11/2019	Holtz et al.	
D747,471 S	1/2016	Gulliver et al.	D870,878 S	12/2019	Wilson	
D747,794 S	1/2016	Greenberg et al.	D875,242 S	2/2020	Gordon	
D750,239 S	2/2016	Pappalardo	D876,617 S	2/2020	Scheirlinck et al.	
9,259,535 B2	2/2016	Anderson et al.	D878,546 S	3/2020	Formica et al.	
D751,687 S *	3/2016	Daly	D878,549 S	3/2020	Wilson	
9,385,257 B2	3/2016	Reuterholt et al.	D879,953 S	3/2020	Ljunglof et al.	
D757,259 S	5/2016	Duck	D879,956 S	3/2020	Klenner	
D757,933 S	5/2016	Lev et al.	10,576,233 B2	3/2020	Harwood	
D759,486 S	6/2016	Ingram	D880,686 S *	4/2020	Stoks	D24/110
D764,049 S	8/2016	Cullen et al.	D887,577 S	6/2020	Shor et al.	
9,440,040 B2	9/2016	Klasek et al.	D893,024 S	7/2020	Whiteside	
D768,285 S	10/2016	Reed	D893,016 S	8/2020	Wilson	
D771,247 S	11/2016	Shinohara et al.	D894,376 S	8/2020	Boyes	
9,480,809 B2	11/2016	Guney et al.	D895,103 S	9/2020	Dantanarayana	
D777,317 S	1/2017	Soual et al.	D896,758 S	9/2020	Watkins	
D777,324 S	1/2017	Nguyen	D896,929 S	9/2020	Vranish	
D781,417 S	3/2017	Ingram	10,786,663 B2	9/2020	Lauer	
D784,525 S	4/2017	Nguyen	D899,590 S	10/2020	Gulliver et al.	
D784,529 S *	4/2017	Steele	10,792,486 B2	10/2020	Nelson	
D785,161 S	4/2017	Dravitzki et al.	D901,673 S	11/2020	Gordon	
D785,789 S	5/2017	Turturro et al.	D903,121 S	11/2020	Chan	
D787,053 S	5/2017	Huang et al.	10,835,733 B1	11/2020	Gulliver et al.	
D787,054 S	5/2017	Rini et al.	D909,564 S	2/2021	Bogan	
D787,661 S	5/2017	Edwards et al.	D910,840 S	2/2021	Klenner et al.	
D790,054 S	6/2017	Prentice et al.	D917,690 S	4/2021	Lau et al.	
9,669,181 B2	6/2017	Miller et al.	D923,169 S	6/2021	McCool et al.	
9,675,774 B2	6/2017	Cipollone	D923,768 S	6/2021	Maeckelberghe et al.	
D791,310 S	7/2017	Maurice	D924,154 S	7/2021	Dykas et al.	
D791,938 S	7/2017	Becker	D924,377 S	7/2021	Kwak et al.	
D791,939 S	7/2017	Turturro et al.	D925,734 S	7/2021	Park	
D792,584 S	7/2017	Ingram et al.	11,052,236 B2	7/2021	Gulliver et al.	
D792,586 S *	7/2017	Becker	D928,925 S	8/2021	Lei	
D794,184 S	8/2017	Smith et al.	D928,948 S	8/2021	Gulliver et al.	
D794,781 S	8/2017	Gilbert et al.	D928,949 S	8/2021	Gulliver et al.	
D800,895 S	10/2017	Prentice	D930,184 S	9/2021	Johnson	
D804,023 S	11/2017	Huang et al.	D933,815 S	10/2021	Eves et al.	
9,808,612 B2	11/2017	Gulliver et al.	D938,016 S	12/2021	Eves et al.	
D804,661 S	12/2017	Shoji et al.	D940,861 S	1/2022	Mosen et al.	
D805,629 S	12/2017	Fiorenza	11,224,728 B2	1/2022	Ignon	
D805,630 S	12/2017	Formica	D944,936 S	3/2022	Chaves et al.	
D807,995 S	1/2018	Maeckelberghe et al.	D944,939 S	3/2022	Chaves	
9,868,001 B2	1/2018	Walker et al.	D947,133 S *	3/2022	Byrne	D13/153
9,879,807 B2	1/2018	Brugger et al.	D948,027 S	4/2022	Babbage et al.	
D809,656 S	2/2018	Lau et al.	D949,294 S	4/2022	Chandler	
9,884,176 B2	2/2018	Fangrow	D949,295 S	4/2022	Chaves	
D816,216 S	4/2018	Gulliver et al.	D958,968 S *	7/2022	Hobbs	D24/110.2
D825,749 S	8/2018	Huang et al.	11,446,462 B2	9/2022	Holyoake et al.	
D827,125 S	8/2018	Nilsson	D968,587 S *	11/2022	Holyoake	D24/110
D827,126 S	8/2018	Nilsson et al.	D970,721 S	11/2022	Ros Fabrega et al.	
D832,431 S *	10/2018	Turturro	11,504,099 B1	11/2022	Smith et al.	
D834,533 S	11/2018	Maroney	D973,862 S *	12/2022	How	D24/110
D834,712 S	11/2018	Gulliver et al.	D973,887 S	12/2022	Rohde, II et al.	
D835,260 S	12/2018	Lisberg	D974,551 S *	1/2023	Mosen	D24/129
D837,743 S	1/2019	Maroney	D975,839 S	1/2023	Kuo	
D841,147 S	2/2019	McCool et al.	D977,087 S	1/2023	Siew	
D841,148 S	2/2019	Stoks et al.	D983,353 S *	4/2023	Babbage	D24/110
10,245,407 B2	4/2019	Osborne	D984,639 S	4/2023	Fang	
10,265,492 B2	4/2019	Amarasinghe et al.	D988,500 S	6/2023	Ishikawa	
D847,752 S	5/2019	Barrefelt	11,690,995 B2	7/2023	Gulliver et al.	
D849,242 S	5/2019	Wilson	D995,758 S	8/2023	McDermott et al.	
			D1,006,981 S	12/2023	Berney et al.	
			2001/0004970 A1	6/2001	Hollister	
			2001/0029949 A1	10/2001	Blackhurst et al.	
			2001/0031819 A1	10/2001	Iwata et al.	

(56)

References Cited

U.S. PATENT DOCUMENTS

2002/0017302 A1 2/2002 Fukunaga et al.
 2002/0112730 A1 8/2002 Dutkiewicz
 2002/0149200 A1 10/2002 Fumioka
 2002/0173748 A1 11/2002 McConnell
 2003/0116963 A1 6/2003 Teuscher et al.
 2003/0136932 A1 7/2003 Doyle
 2004/0090066 A1 5/2004 Hoffmann
 2004/0103686 A1 6/2004 Fehr et al.
 2004/0108218 A1 6/2004 Stubbergh
 2004/0156915 A1 8/2004 Harman et al.
 2004/0261797 A1 12/2004 White et al.
 2005/0011524 A1 1/2005 Thomlinson et al.
 2005/0028822 A1 2/2005 Sleeper et al.
 2005/0077726 A1 4/2005 White et al.
 2005/0085794 A1 4/2005 Denoth et al.
 2005/0283114 A1 12/2005 Bresina
 2006/0107958 A1 5/2006 Sleeper
 2006/0107960 A1 5/2006 Smart
 2006/0113690 A1 6/2006 Huddart
 2007/0043334 A1 2/2007 Guala
 2007/0088327 A1 4/2007 Guala
 2007/0163588 A1 7/2007 Hebrank et al.
 2007/0169825 A1 7/2007 Packham et al.
 2007/0175473 A1 8/2007 Lewis et al.
 2007/0276356 A1 11/2007 Downing et al.
 2008/0041391 A1 2/2008 Worley
 2008/0093846 A1 4/2008 Sparks et al.
 2008/0105257 A1 5/2008 Klasek
 2008/0142019 A1 6/2008 Lewis et al.
 2008/0183153 A1 7/2008 Enns
 2008/0190436 A1 8/2008 Jaffe et al.
 2008/0214990 A1 9/2008 Smutney et al.
 2008/0264413 A1 10/2008 Doherty
 2008/0287920 A1 11/2008 Fangrow et al.
 2009/0101147 A1 4/2009 Landis et al.
 2009/0120434 A1 5/2009 Smith et al.
 2009/0223523 A1 9/2009 Chang
 2009/0223963 A1 9/2009 Bisio
 2009/0240178 A1 9/2009 Hanlon et al.
 2009/0266357 A1 10/2009 Varis et al.
 2009/0299158 A1 12/2009 Boatner et al.
 2010/0043789 A1 2/2010 Fine et al.
 2010/0116272 A1 5/2010 Row et al.
 2010/0148500 A1 6/2010 Uehara et al.
 2010/0163051 A1 7/2010 Brewer et al.
 2010/0168600 A1 7/2010 Adriance et al.
 2010/0192957 A1 8/2010 Hobson et al.
 2010/0206310 A1 8/2010 Matsubara et al.
 2010/0242961 A1 9/2010 Mougel et al.
 2011/0067704 A1 3/2011 Kooij et al.
 2011/0071504 A1 3/2011 Saltell et al.
 2011/0074148 A1 3/2011 Imai
 2011/0120472 A1 5/2011 Lee et al.
 2011/0139151 A1 6/2011 Burns
 2011/0139826 A1 6/2011 Hair
 2011/0162644 A1 7/2011 Ujhazy et al.
 2011/0240031 A1 10/2011 Jaffre
 2011/0253136 A1 10/2011 Sweeney et al.
 2011/0265796 A1 11/2011 Amarasinghe et al.
 2012/0157914 A1 6/2012 Stroup
 2012/0247477 A1 10/2012 Stephenson et al.
 2012/0305001 A1 12/2012 Tatkov
 2013/0037030 A1 2/2013 Matula
 2013/0104888 A1 5/2013 Landis et al.
 2013/0133651 A1 5/2013 Barker et al.
 2013/0167841 A1 7/2013 Sheffer et al.
 2013/0245611 A1 9/2013 Bonnet et al.
 2013/0255670 A1 10/2013 Ott et al.
 2013/0264821 A1 10/2013 Duck
 2013/0284167 A1 10/2013 Porteous et al.
 2013/0292592 A1 11/2013 Py
 2014/0000626 A1 1/2014 O'Connor et al.
 2014/0014108 A1 1/2014 Dillard
 2014/0053846 A1 2/2014 Wood
 2014/0144438 A1 5/2014 Klasek

2014/0158127 A1 6/2014 Boucher et al.
 2014/0191501 A1 7/2014 Brugger et al.
 2014/0200475 A1 7/2014 Rubin
 2014/0238401 A1 8/2014 Paschall
 2014/0261416 A1 9/2014 Arcilla et al.
 2014/0338669 A1 11/2014 Zhao et al.
 2014/0373841 A1 12/2014 Nashed
 2015/0059745 A1 3/2015 Barker et al.
 2015/0083121 A1 3/2015 Fisher
 2015/0128944 A1 5/2015 Buechi
 2015/0167877 A1 6/2015 Kendrick
 2015/0209568 A1 7/2015 Rosenquist
 2015/0290416 A1 10/2015 Klasek
 2015/0306332 A1 10/2015 Bafle et al.
 2015/0320949 A1 11/2015 Jaffe
 2015/0320962 A1 11/2015 Bafle et al.
 2016/0001031 A1 1/2016 Laing et al.
 2016/0038701 A1 2/2016 White et al.
 2016/0082218 A1 3/2016 Lau
 2016/0106913 A1 4/2016 Ng et al.
 2016/0131292 A1 5/2016 Decker
 2016/0193440 A1 7/2016 Sheffer et al.
 2016/0199634 A1 7/2016 Gagliardoni et al.
 2016/0228668 A1 8/2016 Martin
 2016/0287824 A1 10/2016 Chang
 2016/0305574 A1 10/2016 Burdge
 2017/0036007 A1 2/2017 Hallisey et al.
 2017/0065788 A1 3/2017 Chou
 2017/0065789 A1 3/2017 Reed
 2017/0197055 A1 7/2017 Moody
 2017/0333662 A1 11/2017 Ovinsky et al.
 2017/0361051 A1 12/2017 Eifler
 2018/0064901 A1 3/2018 Colman
 2018/0085544 A1 3/2018 Holyoake
 2018/0117270 A1 5/2018 Bassin
 2018/0140819 A1 5/2018 Yang
 2018/0200148 A1 7/2018 Sanders
 2019/0022344 A1 1/2019 Lau et al.
 2019/0151842 A1 5/2019 Williams et al.
 2019/0167935 A1 6/2019 Siew et al.
 2019/0381268 A1 12/2019 Colman
 2020/0129724 A1 4/2020 Nelson
 2021/0205589 A1* 7/2021 Dong A61M 39/10
 2021/0322706 A1 10/2021 Lau et al.
 2021/0402126 A1 12/2021 Lau et al.
 2021/0402127 A1 12/2021 Lau et al.
 2023/0021629 A1 1/2023 Ranjitsingh
 2023/0147017 A1 5/2023 Holyoake
 2023/0381484 A1 11/2023 Gulliver et al.

FOREIGN PATENT DOCUMENTS

CN 201775849 3/2011
 CN 102019014 4/2011
 DE 3709122 9/1988
 DE 19615290 1/1998
 DE 102007063556 7/2009
 EM 000254420-0014 11/2004
 EM 008110019-0001 9/2020
 EM 008110019-0002 9/2020
 EP 1 068 889 1/2001
 EP 1 181 945 2/2002
 EP 0 809 768 7/2002
 EP 1 277 488 1/2003
 EP 1 314 446 5/2003
 EP 1 403 838 3/2004
 EP 1 408 313 4/2004
 EP 1 479 405 11/2004
 EP 1 481 702 12/2004
 EP 1 520 599 4/2005
 EP 1 023 912 B1 11/2005
 EP 1 449 502 12/2007
 EP 1 933 074 6/2018
 EP 2 906 287 6/2019
 EP 2 877 224 9/2020
 EP 2 925 396 9/2020
 GB 1563359 3/1980
 GB 2328260 2/1999
 JP 09-028806 2/1997

(56)

References Cited

FOREIGN PATENT DOCUMENTS

JP	2002-126094	5/2002
JP	2007-236567	9/2007
JP	D1639030	8/2019
JP	D1723039	8/2022
JP	D1737290	2/2023
KR	1020040103139	12/2004
KR	3012026700001	* 3/2023
MY	13-1228-0303-0001	8/2014
TW	223055-0001	1/2023
TW	226455-0001	* 7/2023
WO	WO 90/014122	11/1990
WO	WO 94/004211	3/1994
WO	WO 97/015376	5/1997
WO	WO 97/48433	12/1997
WO	WO 99/012598	3/1999
WO	WO 03/090827	11/2002
WO	WO 03/082406	10/2003
WO	WO 04/108218	12/2004
WO	WO 05/018524	3/2005
WO	WO 05/079670	9/2005
WO	WO 05/102431	11/2005
WO	WO 07/019625	2/2007
WO	WO 07/024812	3/2007
WO	WO 08/144298	11/2008
WO	WO 08/144447	11/2008
WO	WO 09/094532	7/2009
WO	WO 09/146484	12/2009
WO	WO 11/062510	5/2011
WO	WO 11/079226	6/2011
WO	WO 12/052903	4/2012
WO	WO 13/022356	2/2013
WO	WO 13/088439	6/2013
WO	WO 13/127474	9/2013
WO	WO 14/015382	1/2014
WO	WO 14/077706	5/2014
WO	WO 14/097145	6/2014
WO	WO 14/129912	8/2014
WO	WO 2014/205513	12/2014
WO	WO 15/038014	3/2015
WO	WO 2015/142192	9/2015
WO	WO 16/157101	10/2016
WO	WO 16/157105	10/2016

OTHER PUBLICATIONS

Fisher & Paykel Healthcare Limited, Junior Tube and Chamber Kit brochure, 900PT531, 2012.

Replacement Tube Assembly for WIS_P, IBEET Short Tube Supplies—Quick Release & 360-Degree Rotatable, IBEET, Amazon.com, [Post date: Oct. 28, 2021], Seen at URL: [https://www.amazon.com/Replacement-Tube-Assembly-Short-Supplies/dp/ B09GM12TMG](https://www.amazon.com/Replacement-Tube-Assembly-Short-Supplies/dp/B09GM12TMG) (Year: 2021), 4 pp.

Salter Labs, “Air-Q Intubating Laryngeal Airways (ILA) The everyday airway that’s ready for the unexpected.”; Dec. 2018; 8 pages. AQR Safety Connection, Staubli, [Post date: Nov. 29, 2023], [Site seen Aug. 9, 2023], Seen at URL: <https://www.staubli.com/fr/en/fluid-connectors/products/quick-and-dry-disconnect-couplings/breathing-air.html> (Year: 2023).

Huapa Mini hose connector for CPAP hose CPAP accessories Resmed air nasal masks, Amazon.com, first posted Oct. 9, 2018, <https://amzn.to/3x62sdy>, 8 pp.

JML Medical, Adaptor One Way Valve 220Dx221D w/Oxygen Stem, Teleflex, [Post date unknown], downloaded May 19, 2022, <https://www.jmlmed.com/collections/respiratory-products/products/one-way-valve-by-teleflex>, 2 pp.

New Leaf Home Medical, Pressure Line Adaptor for Ventilation Accessories, Medline, [Post date Unknown], downloaded May 19, 2022 <https://newleafhomemedical.com/pressure-line-adaptor-for-ventilation-accessories/>, 1 p.

Prestan Rescue Mask Adapters 50 Pack, Prestan, heartsmart.com, [Post date: unknown], [Site seen Aug. 9, 2023], Seen at URL: <https://www.heartsmart.com/prestan-rescue-mask-adapters-p> (Year: 2023).

RC Medical Incorporated, Hudson Dual Spray MDI Adaptor, CS/50, [Post date: Post date unknown], downloaded, May 19, 2022, <https://www.rcmedical.com/viewProduct.cfm?productID=871>, 1 p.

Fisher & Paykel ICON ThermoSmart Heated CPAP Tubing, 6 Foot, Fisher & Paykel, [Post date unknown], [Site seen Mar. 23, 2023], Seen at URL: <https://helpmedicalsupplies.com/products/6-thermosmart-heated-hose-tubing-for-f-p-icon-cpap-machine?variant=9981444522099> (Year: 2023), 1 p.

Pall Corporation, Jun. 10, 2019, Multiple-Patient-Use Anesthesia Circuits, product description, 5 pp.

[Photos of current commercial connector illustrated in reference 1, 3 pages.

Replacement Non-Heated Hose Tubing for Fisher & Paykel SleepStyle Auto CPAP Machine, Fisher & Paykel, .cpapstoreusa.com, [Post Date: Jun. 26, 2022], [Site seen Mar. 23, 2023], Seen at URL: [https://www.cpapstoreusa.com/product/ replacement-non-heated-hose-tubing-for-fisher-paykel-sleepstyle-auto-cpap-machine/](https://www.cpapstoreusa.com/product/replacement-non-heated-hose-tubing-for-fisher-paykel-sleepstyle-auto-cpap-machine/) (Year: 2022), 1 p.

* cited by examiner

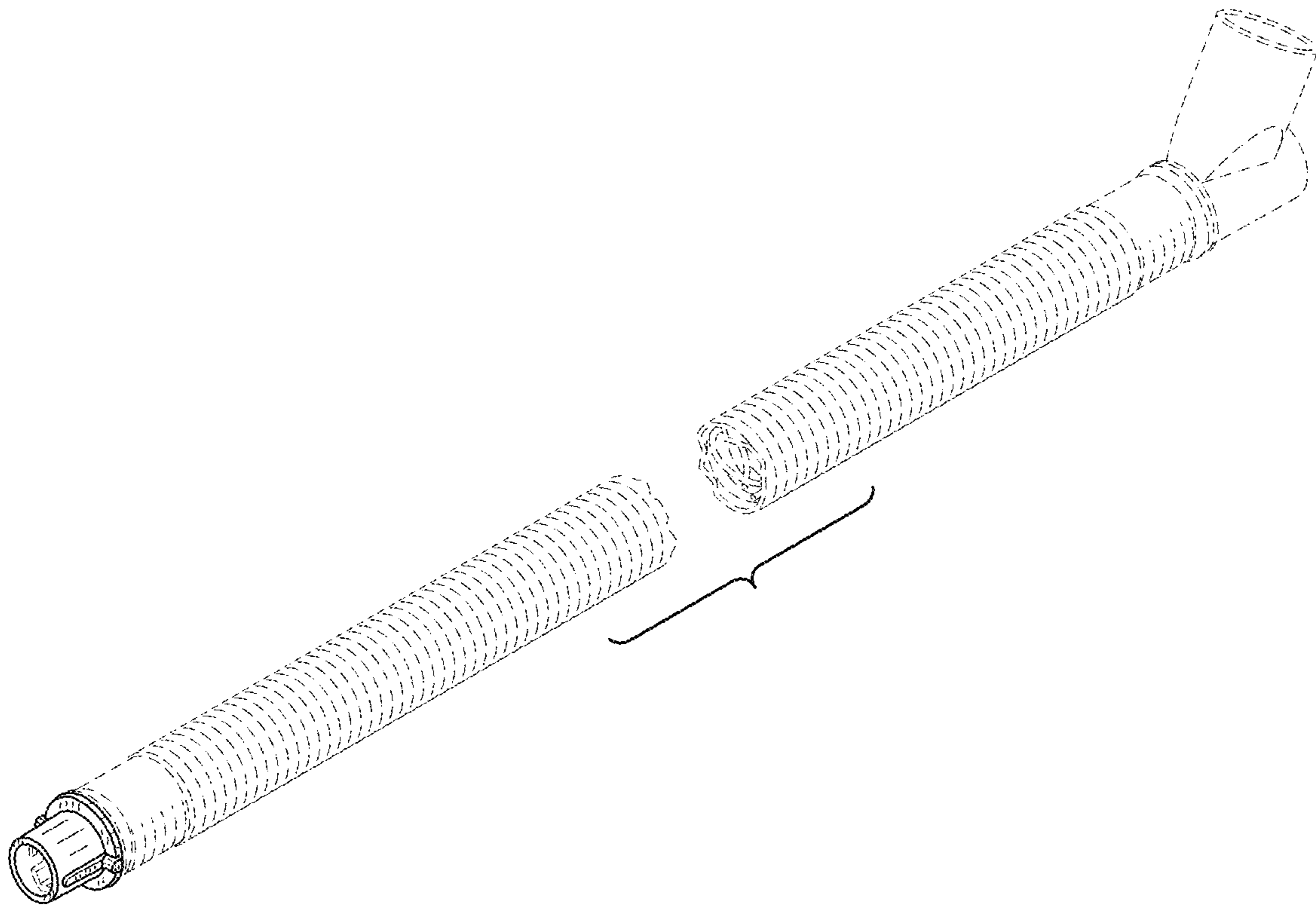

FIG. 1

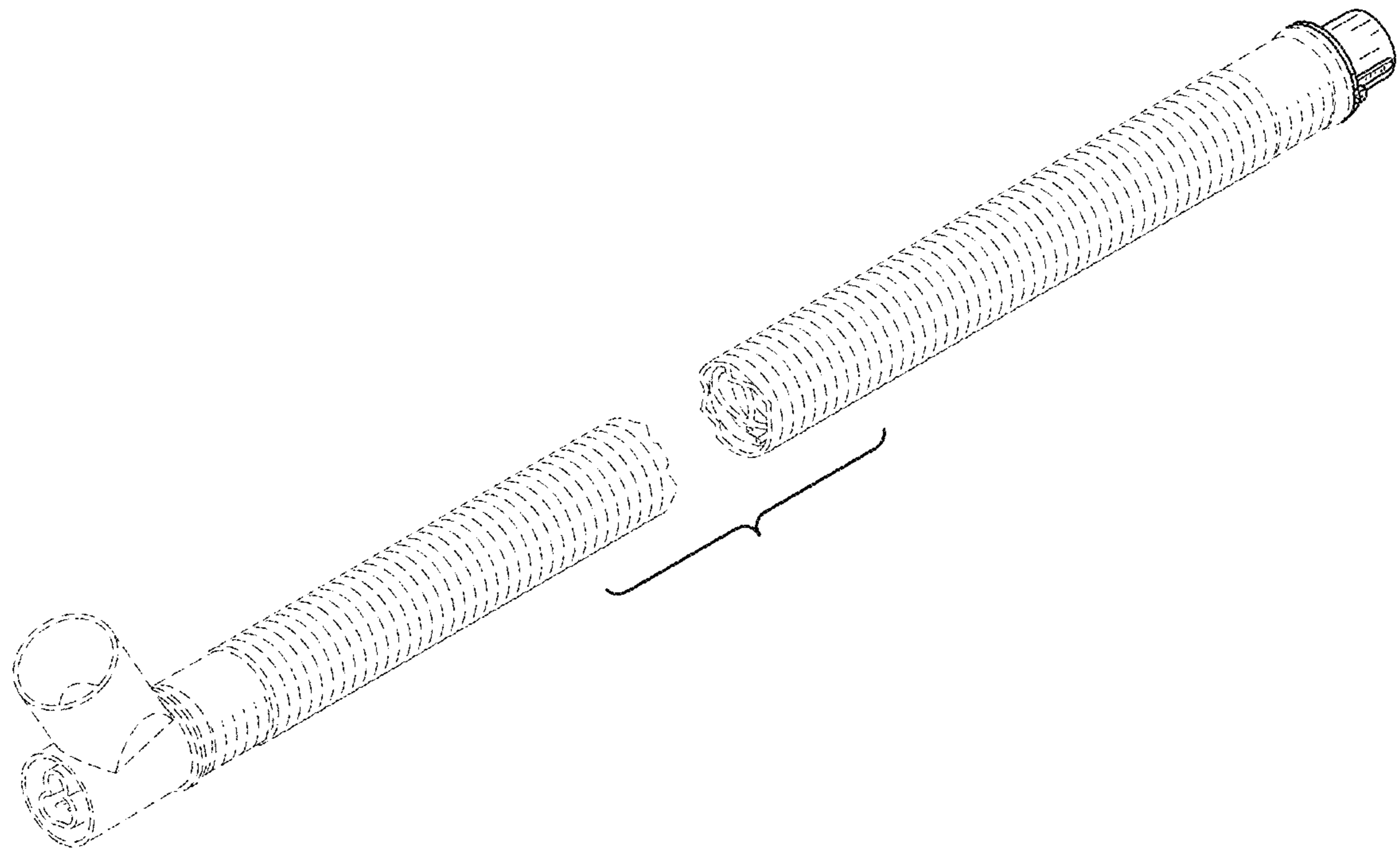

FIG. 2

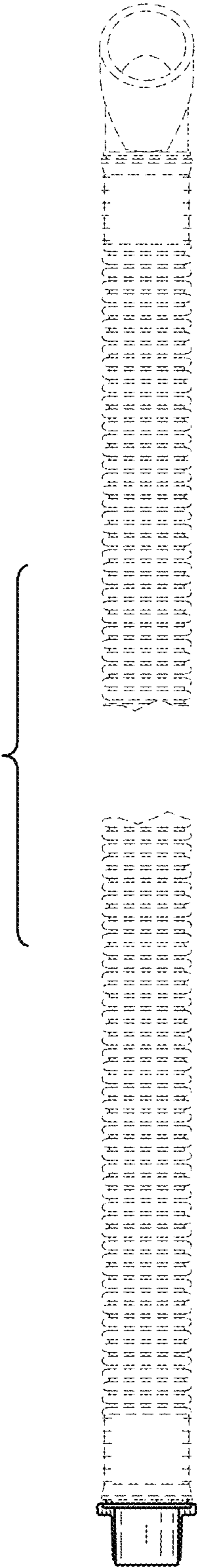

FIG. 3

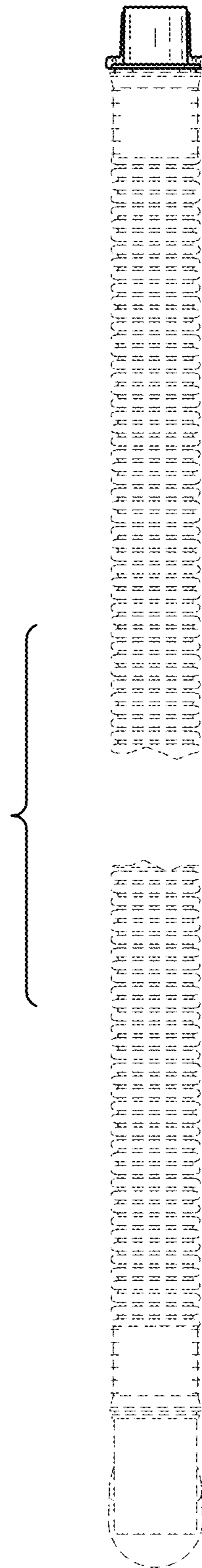

FIG. 4

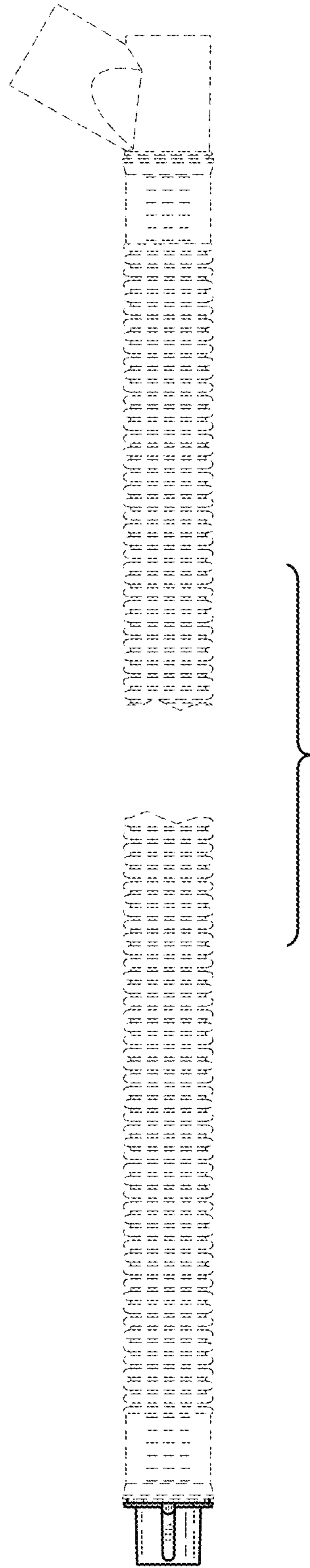

FIG. 5

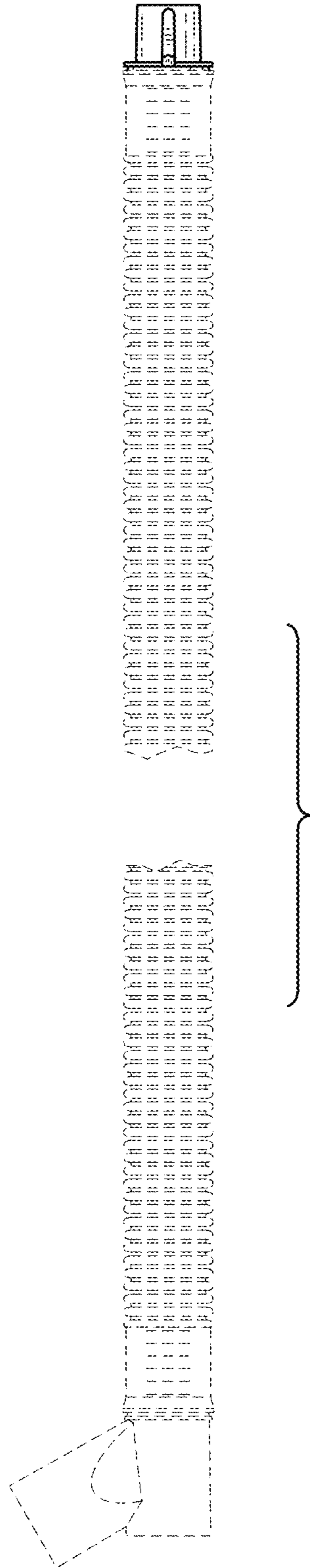

FIG. 6

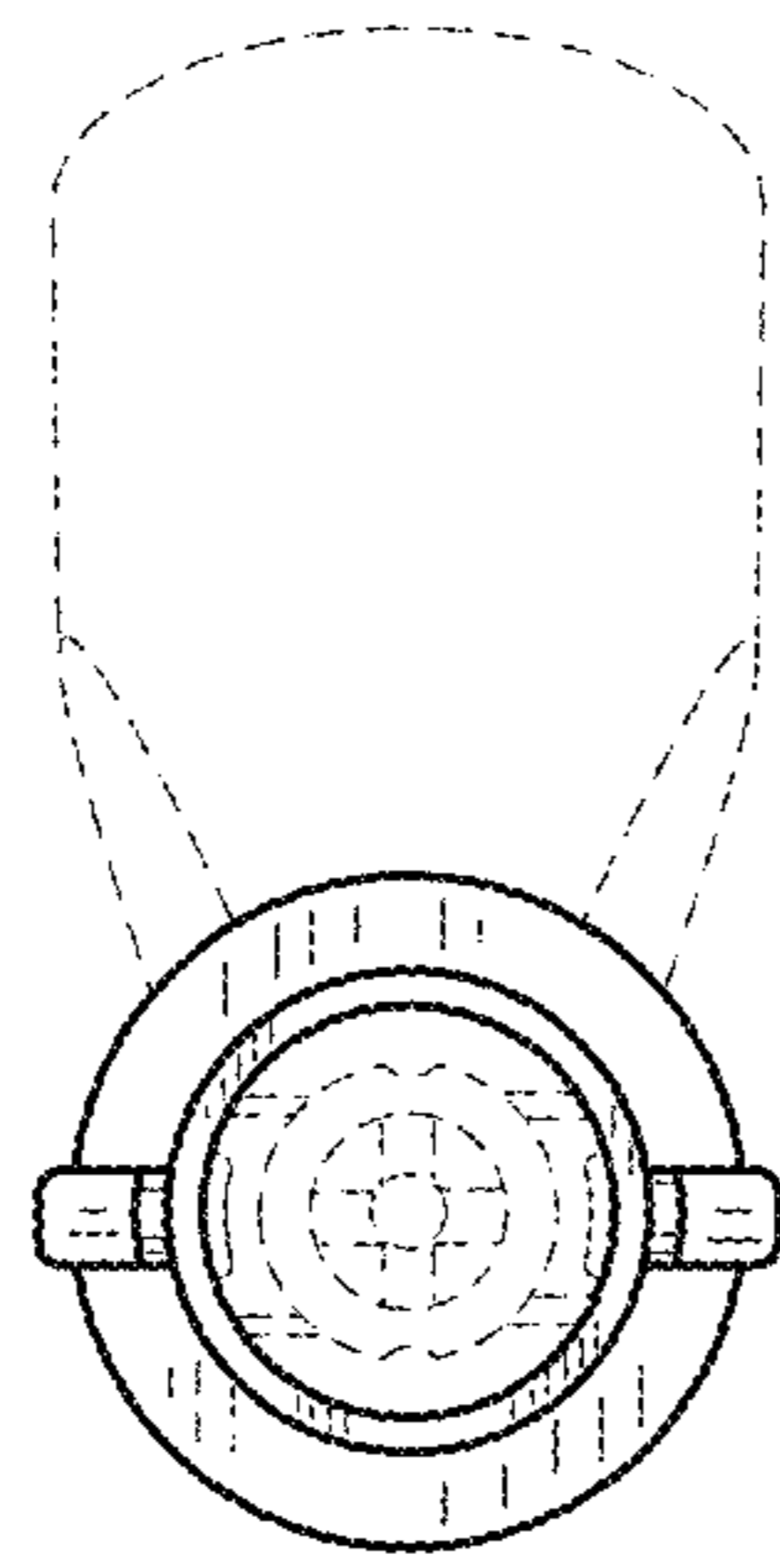

FIG. 7

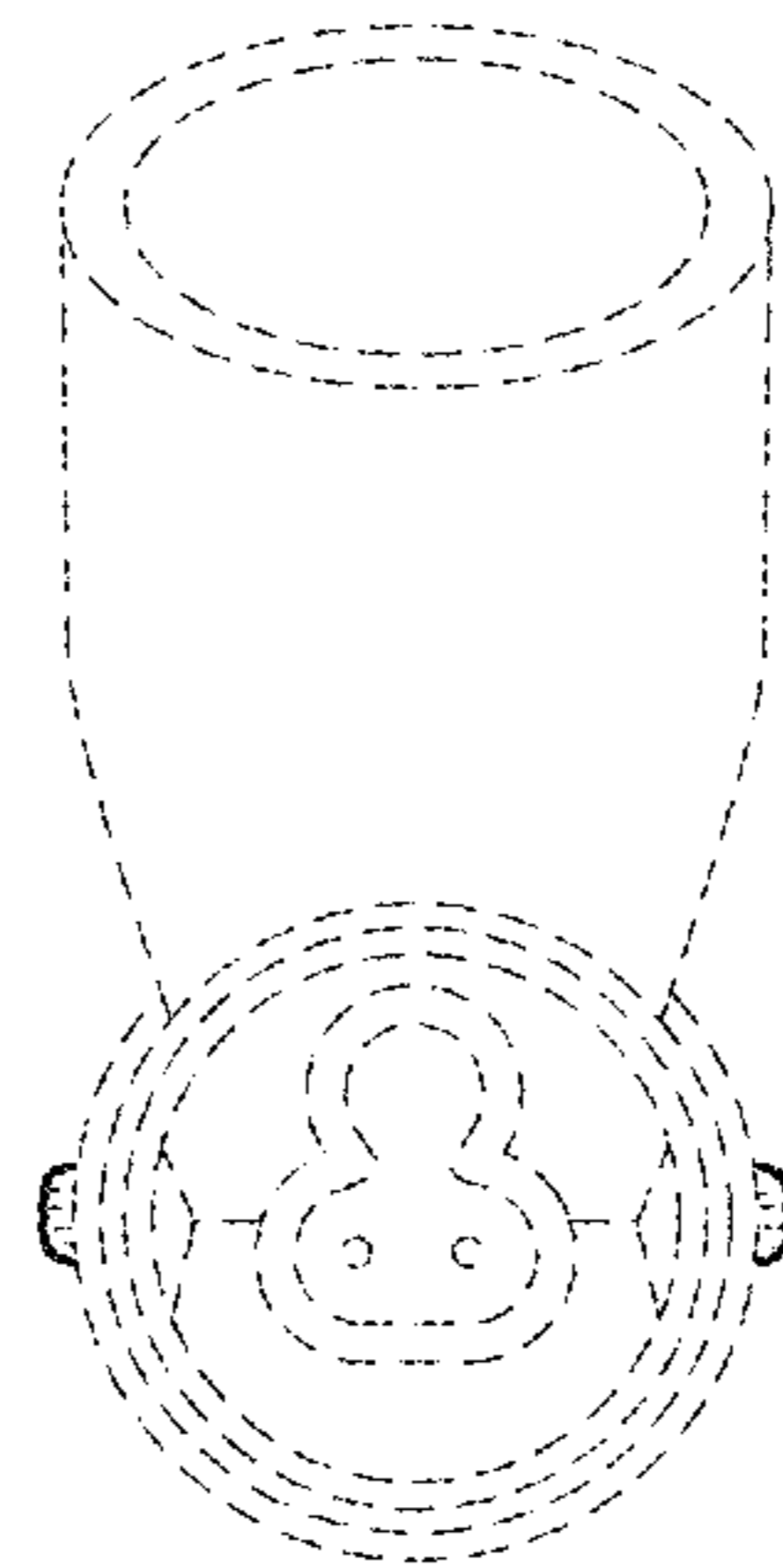

FIG. 8