



US0D1035949S

(12) **United States Design Patent**
Hopkins

(10) **Patent No.:** **US D1,035,949 S**

(45) **Date of Patent:** **** *Jul. 16, 2024**

(54) **FLASHLIGHT**

D673,705 S * 1/2013 Inskip D26/45
D788,341 S * 5/2017 Inskip D26/45
D823,429 S * 7/2018 Wood D23/208

(71) Applicant: **Daniel Glen Hopkins**, West Linn, OR
(US)

* cited by examiner

(72) Inventor: **Daniel Glen Hopkins**, West Linn, OR
(US)

Primary Examiner — Marissa J Cash

(*) Notice: This patent is subject to a terminal disclaimer.

Assistant Examiner — William B Melliar

(**) Term: **15 Years**

(57) **CLAIM**

(21) Appl. No.: **29/756,151**

The ornamental design for a flashlight, as shown and described.

(22) Filed: **Oct. 26, 2020**

(51) **LOC (14) Cl.** **26-02**

(52) **U.S. Cl.**
USPC **D26/45**

DESCRIPTION

(58) **Field of Classification Search**
USPC D26/24, 37-52, 113
CPC F21Y 2115/10; F21Y 2101/00; F21V
23/0414; F21V 15/01; F21V 21/0885;
F21V 14/045; F21V 23/0421; F21V
14/025; F21V 21/145; F21V 21/0965;
F21V 5/006; F21V 14/065; F21V 7/0075;
F21V 9/083; F21V 13/045; F21L 4/005;
F21L 4/027; F21L 4/00; F21L 4/085;
F21L 4/022; F21L 4/045; F21L 14/02;
F21L 14/00; F21L 2001/00

FIG. 1 is a front-top perspective view of a flashlight showing my new design;
FIG. 2 is a front-bottom perspective view thereof;
FIG. 3 is a rear-top perspective view thereof;
FIG. 4 is a rear-bottom perspective view thereof;
FIG. 5 is a front elevational view thereof;
FIG. 6 is a rear elevational view thereof;
FIG. 7 is a left elevational view thereof;
FIG. 8 is a right elevational view thereof;
FIG. 9 is a top plan view thereof; and,
FIG. 10 is a bottom plan view thereof.

See application file for complete search history.

The broken lines shown in the drawings depict portions of the flashlight that form no part of the claimed design.

(56) **References Cited**

U.S. PATENT DOCUMENTS

D201,913 S * 8/1965 Raymond D26/45
D207,552 S * 5/1967 Perkins D26/45
D291,227 S * 8/1987 Evans D26/37
D527,130 S * 8/2006 Garrity D26/45

1 Claim, 10 Drawing Sheets

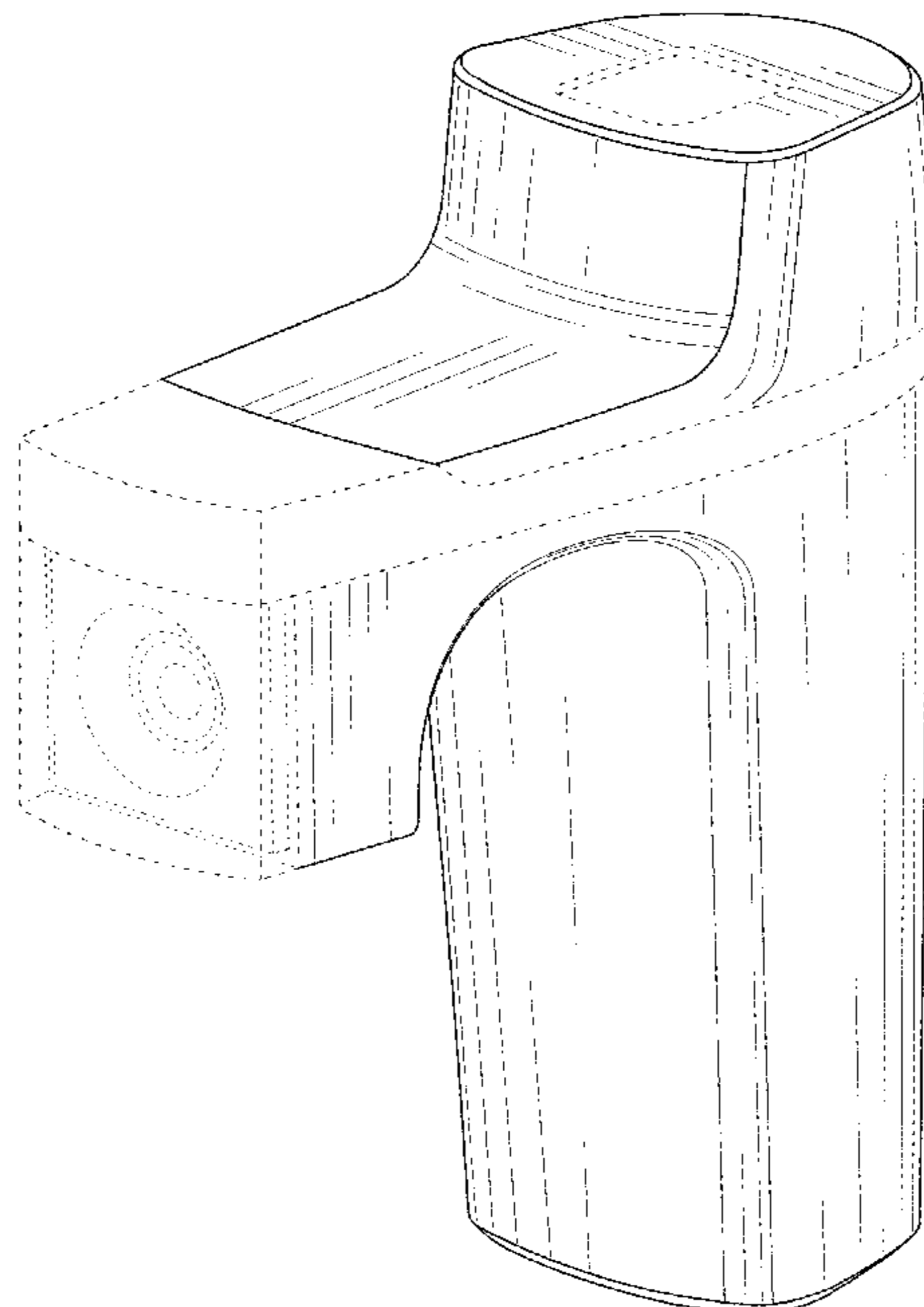

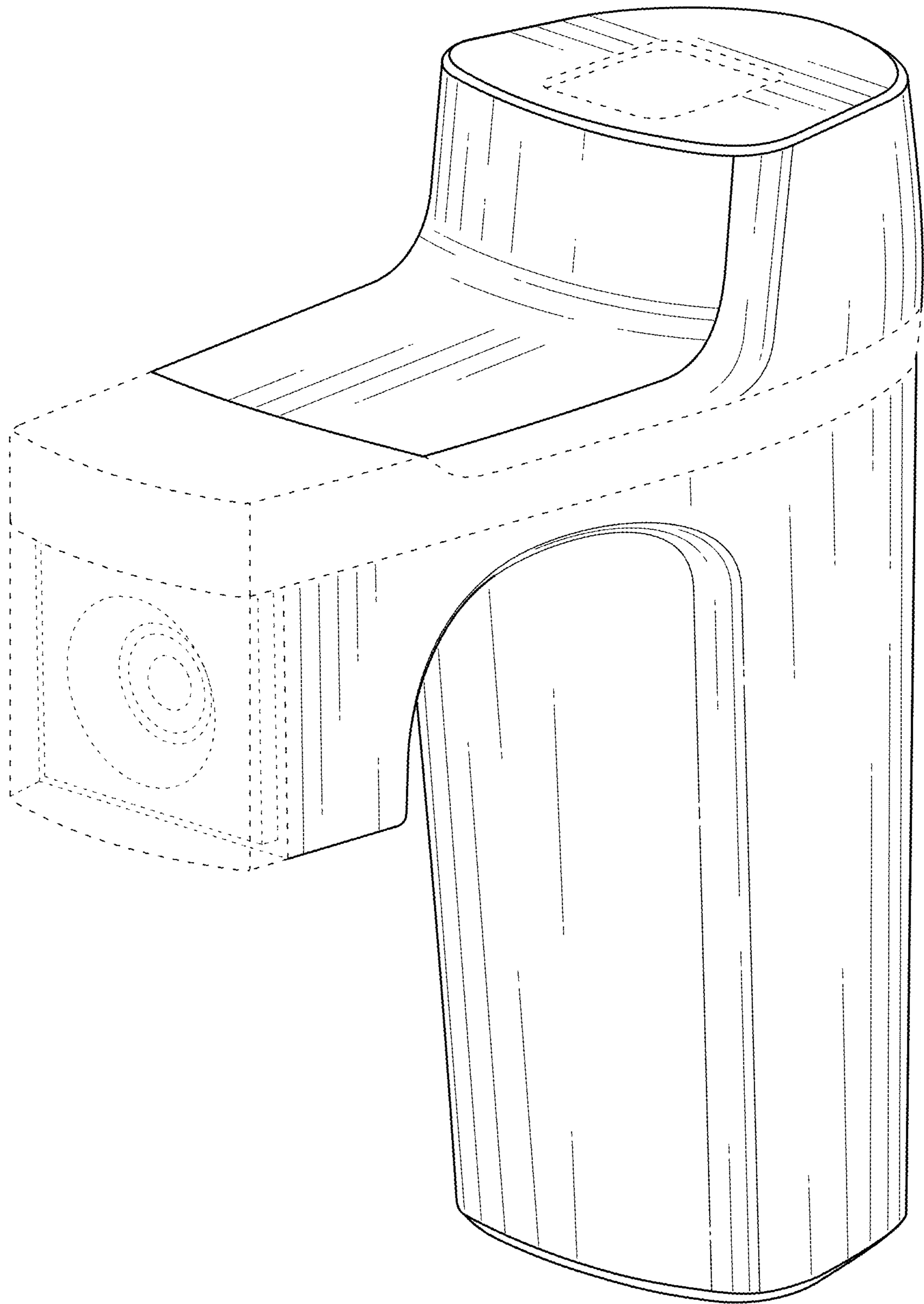

FIG. 1

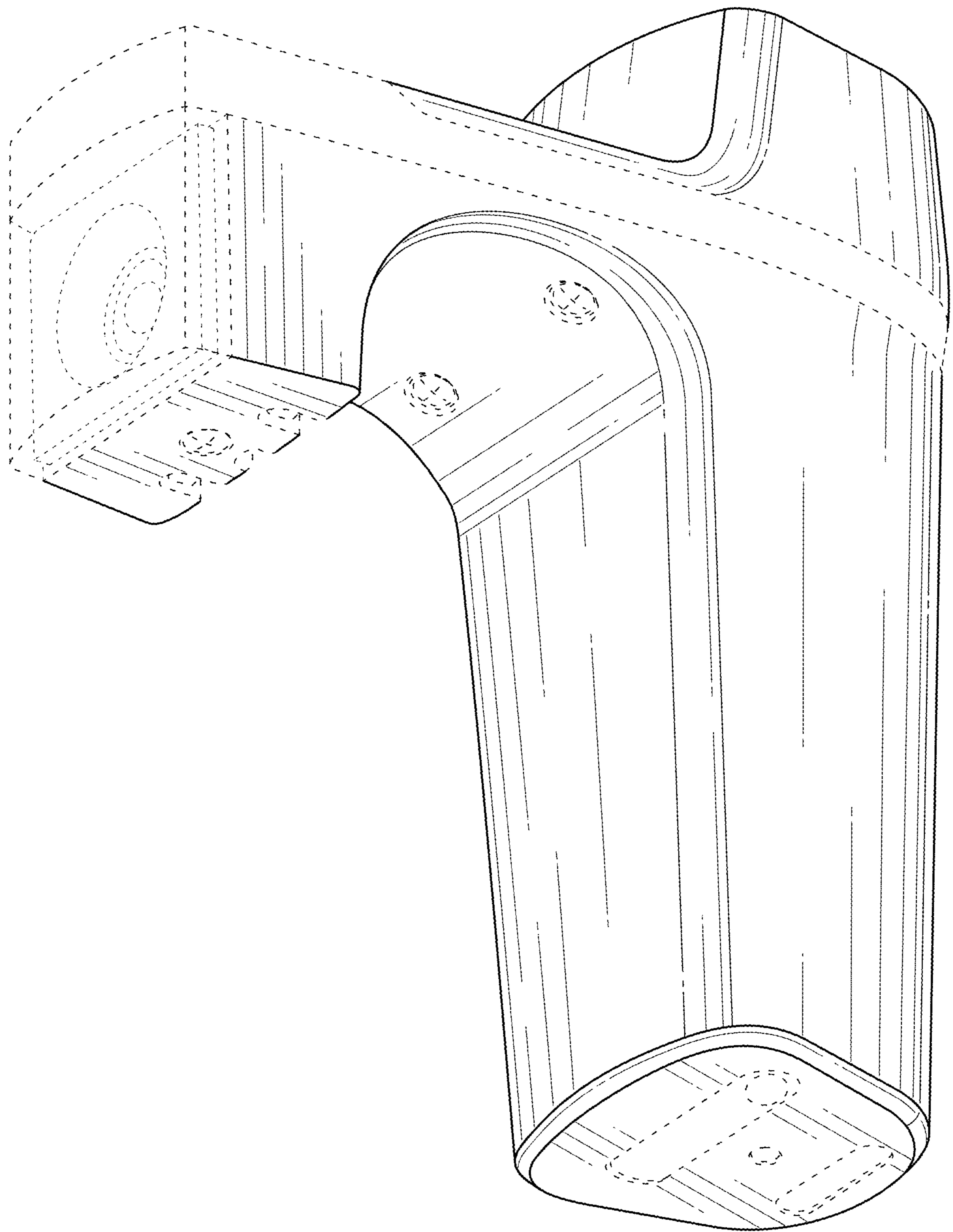

FIG. 2

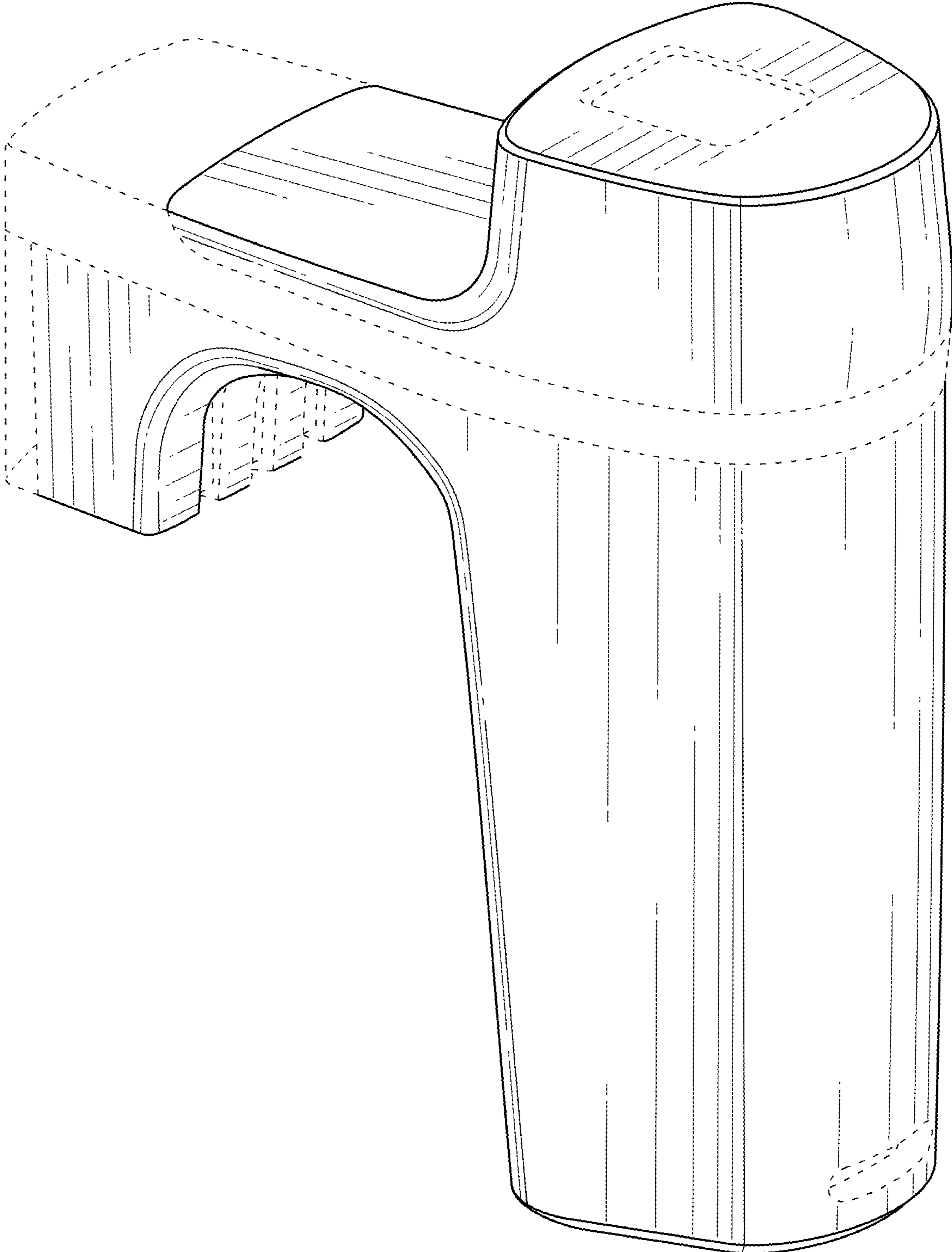

FIG. 3

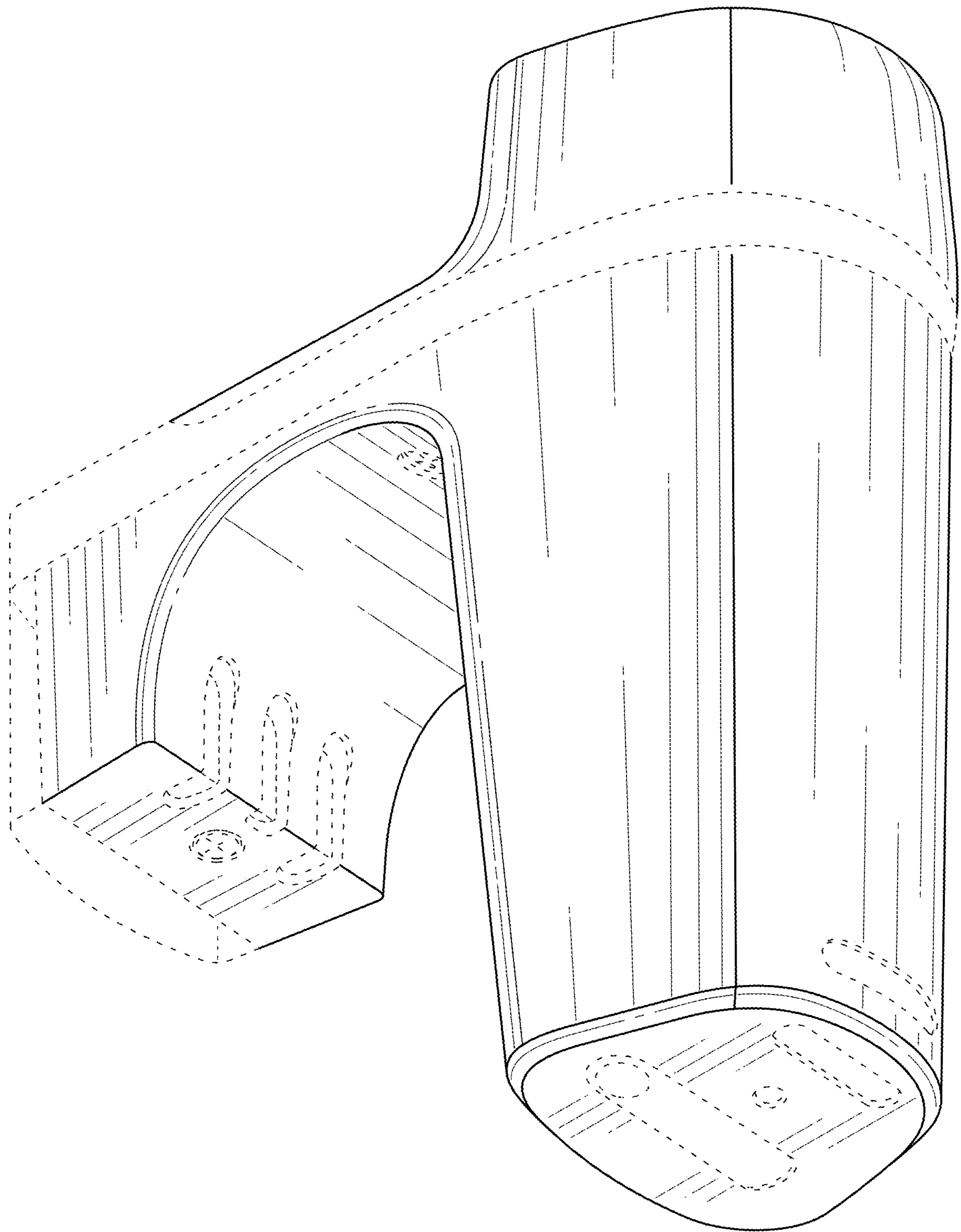

FIG. 4

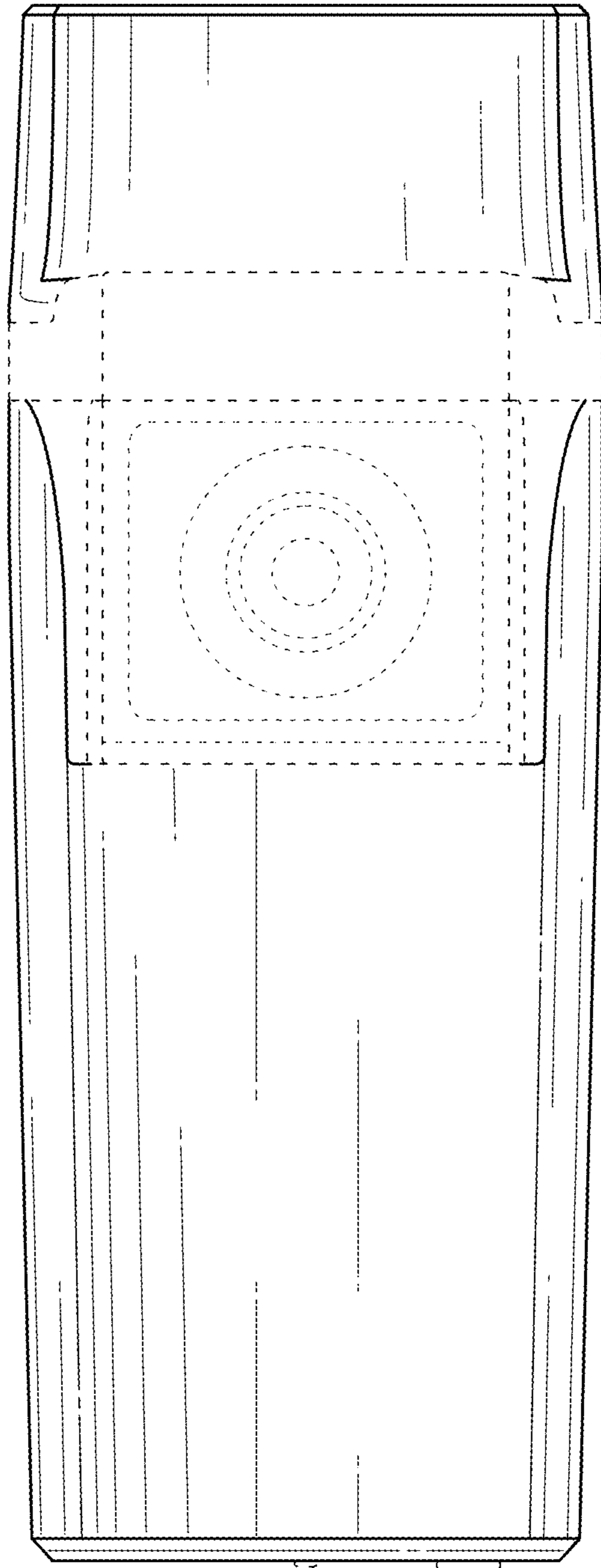

FIG. 5

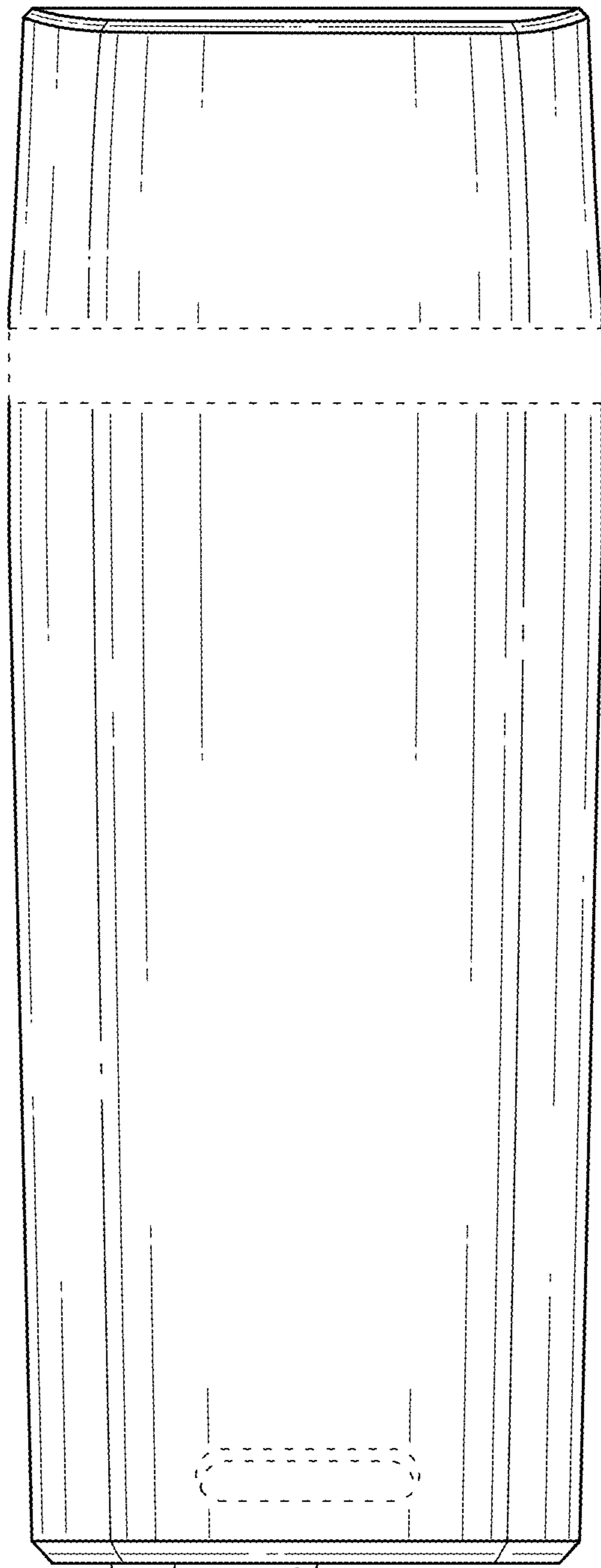

FIG. 6

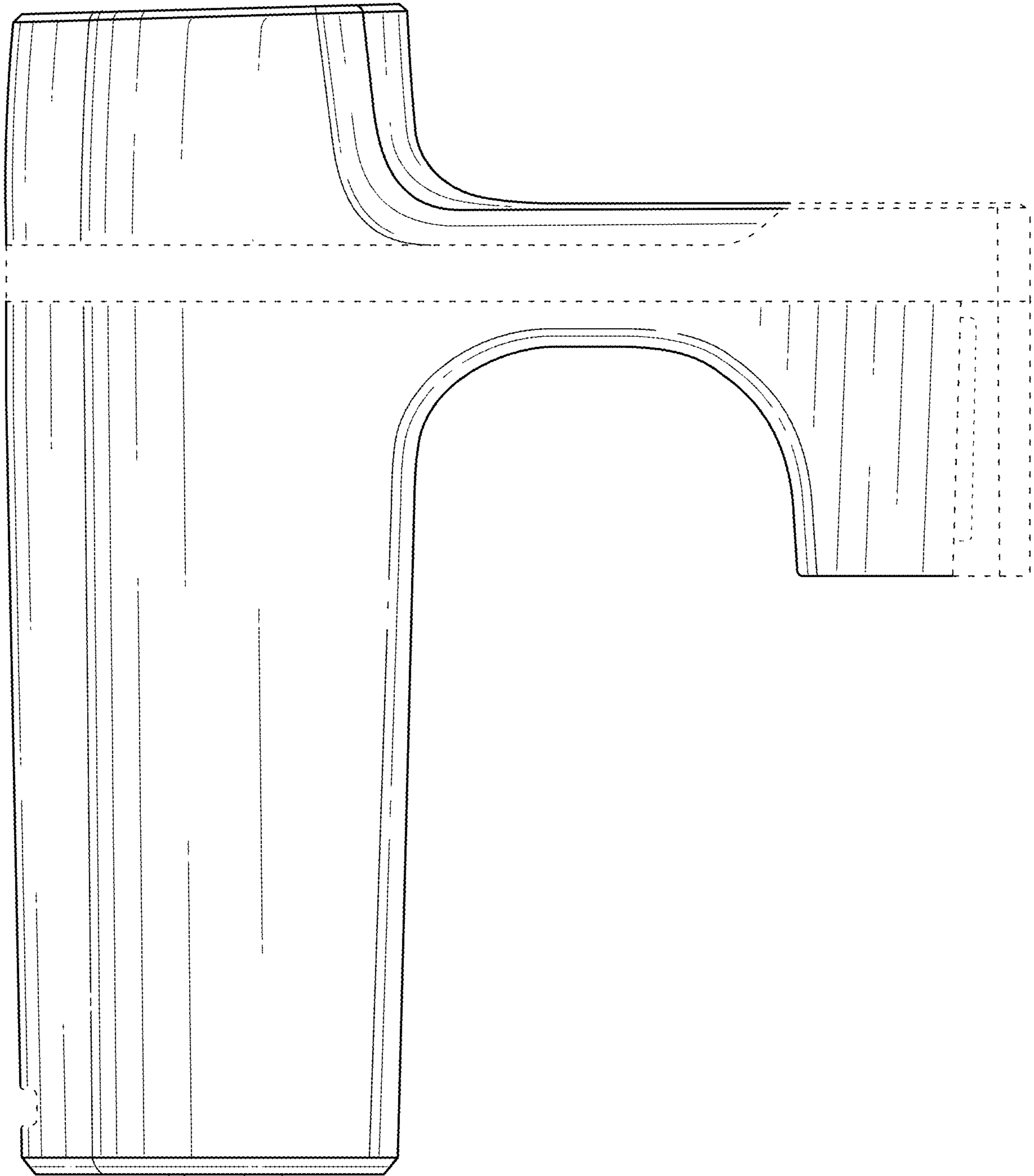

FIG. 7

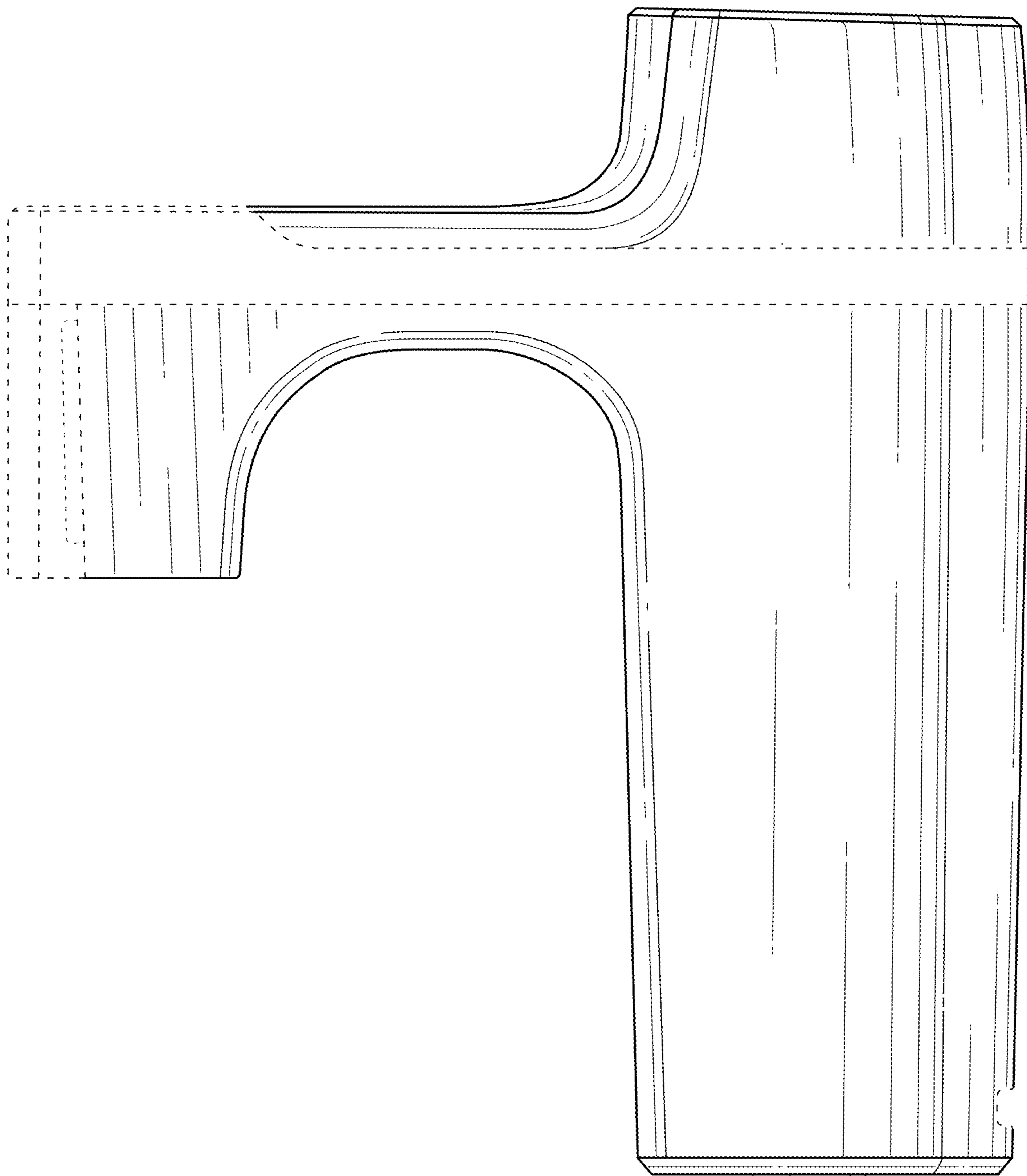

FIG. 8

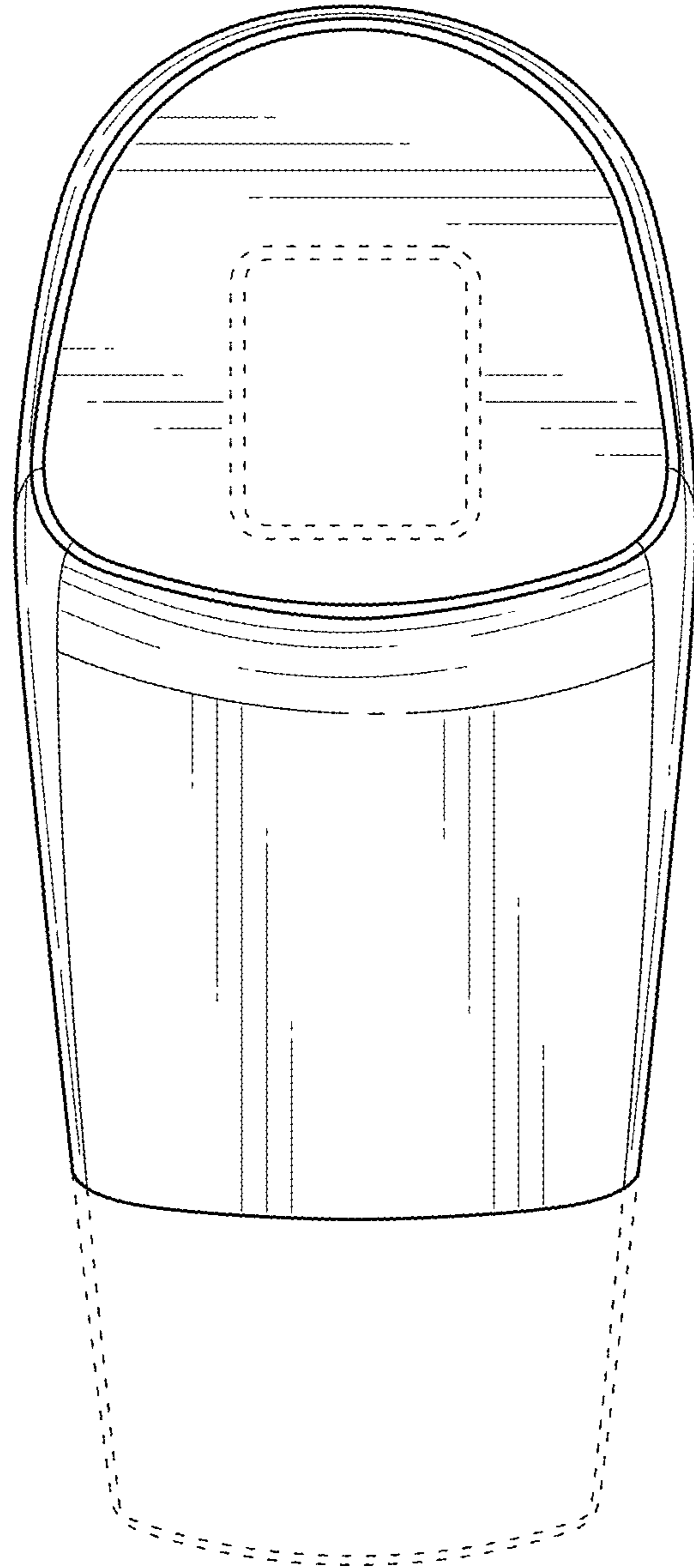

FIG. 9

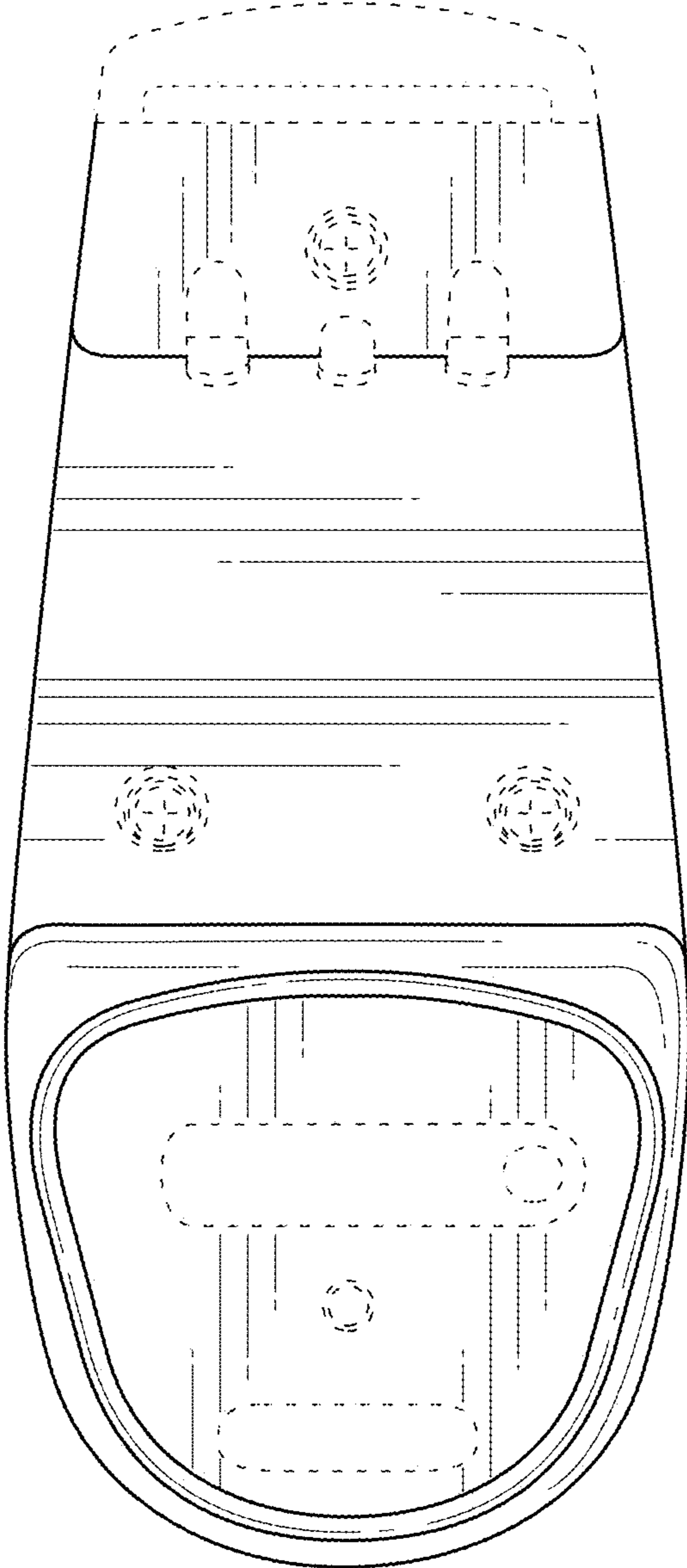

FIG. 10