



US0D1033637S

(12) **United States Design Patent** (10) **Patent No.:** **US D1,033,637 S**
Horvath et al. (45) **Date of Patent:** **** Jul. 2, 2024**

(54) **FLUID EXCHANGE DEVICE**

FOREIGN PATENT DOCUMENTS

(71) Applicant: **Genentech, Inc.**, South San Francisco, CA (US)

CA 134128 * 4/2010
CA 170342 * 3/2017

(Continued)

(72) Inventors: **Joshua David Horvath**, San Ramon, CA (US); **Kristof Hovaten**, South San Francisco, CA (US); **Daniel Douglass**, South San Francisco, CA (US); **Keith Bianchi**, South San Francisco, CA (US)

OTHER PUBLICATIONS

The invisible needle, TSK, [Post date: Unknown], [Site seen Nov. 15, 2023], Seen at URL: <https://www.tsklab.com/ophthalmic-needles/> (Year: 2023).*

(Continued)

(73) Assignee: **ForSight Vision4, Inc.**, South San Francisco, CA (US)

(**) Term: **15 Years**

Primary Examiner — Natasha Vujcic
Assistant Examiner — Gilbert B Ford

(21) Appl. No.: **29/824,354**

(74) *Attorney, Agent, or Firm* — Mintz Levin Cohn Ferris Glovsky and Popeo, P.C.

(22) Filed: **Jan. 24, 2022**

(51) **LOC (14) Cl.** **24-02**

(57) **CLAIM**

(52) **U.S. Cl.**
USPC **D24/130; D24/112; D24/150**

The ornamental design for a fluid exchange device, as shown and described.

(58) **Field of Classification Search**
USPC D24/127–131, 133, 186, 110, D24/110.1–110.6, 113, 108
CPC A61M 16/0816; A61M 16/0875; A61M 39/105; A61M 2016/003; A61M 2039/1088

See application file for complete search history.

DESCRIPTION

FIG. 1 is a bottom, front, and right side perspective view of a fluid exchange device of our design; FIG. 2 is a top, front, and left side perspective view thereof; FIG. 3 is a bottom, rear, and right side perspective view thereof; FIG. 4 is a right side view thereof; FIG. 5 is a left side view thereof; FIG. 6 is a rear view thereof; FIG. 7 is a front view thereof; FIG. 8 is a bottom view thereof; FIG. 9 is a top view thereof; FIG. 10 is an enlarged view taken from FIG. 1; and, FIG. 11 is an enlarged view taken from FIG. 2. The dash-dash broken lines illustrate portions of the fluid exchange device that form no part of the claimed design.

(56) **References Cited**

U.S. PATENT DOCUMENTS

| | | |
|-------------|---------|--------------|
| 1,747,814 A | 2/1930 | Bradley |
| 2,564,977 A | 8/1951 | Hu |
| 2,585,815 A | 2/1952 | McLintock |
| 2,646,042 A | 7/1953 | Hu |
| 2,886,497 A | 5/1959 | Butler |
| 3,232,117 A | 2/1966 | Gilmont |
| 3,416,530 A | 12/1968 | Ness |
| 3,612,089 A | 10/1971 | Beguiristain |
| 3,618,604 A | 11/1971 | Ness |

(Continued)

1 Claim, 6 Drawing Sheets

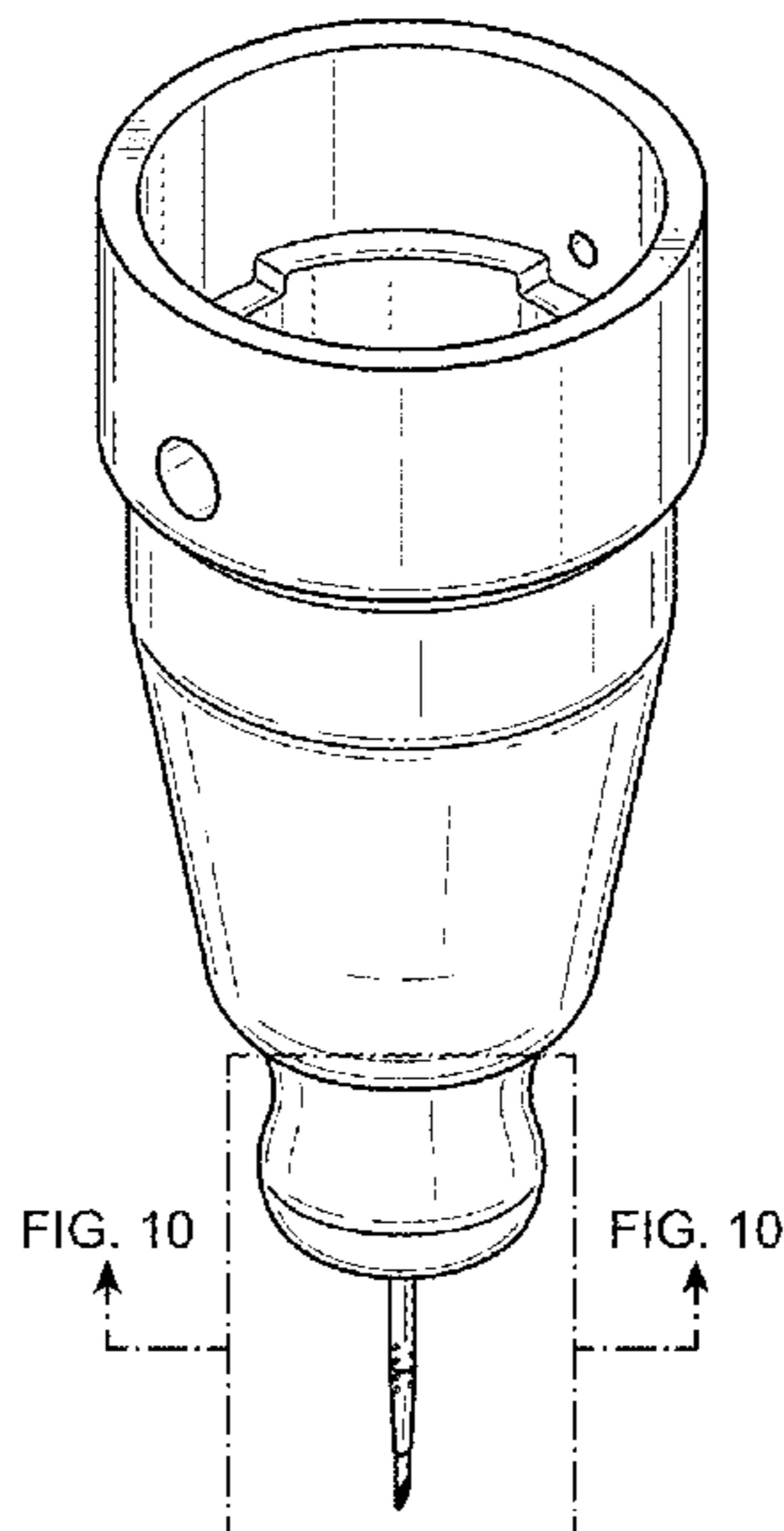

(56)

References Cited

U.S. PATENT DOCUMENTS

| | | | | | |
|-------------|---------|----------------------|--------------|---------|---------------------|
| 3,641,237 A | 2/1972 | Gould et al. | 5,282,829 A | 2/1994 | Hermes |
| 3,734,095 A | 5/1973 | Santomieri | 5,300,114 A | 4/1994 | Gwon et al. |
| 3,828,777 A | 8/1974 | Ness | 5,322,504 A | 6/1994 | Doherty et al. |
| 3,831,583 A | 8/1974 | Edmunds, Jr. et al. | 5,322,691 A | 6/1994 | Darougar et al. |
| 3,845,201 A | 10/1974 | Haddad et al. | 5,324,518 A | 6/1994 | Orth et al. |
| 3,902,495 A | 9/1975 | Weiss et al. | 5,334,189 A | 8/1994 | Wade |
| 3,914,402 A | 10/1975 | Shell | 5,336,175 A | 8/1994 | Mames |
| 3,916,899 A | 11/1975 | Theeuwes et al. | 5,358,473 A | 10/1994 | Mitchell |
| 3,926,188 A | 12/1975 | Baker et al. | 5,364,343 A | 11/1994 | Apolet et al. |
| 3,949,748 A | 4/1976 | Malmin | 5,378,475 A | 1/1995 | Smith et al. |
| 3,949,750 A | 4/1976 | Freeman | 5,413,572 A | 5/1995 | Wong et al. |
| 3,961,628 A | 6/1976 | Arnold | 5,443,505 A | 8/1995 | Wong et al. |
| 3,977,404 A | 8/1976 | Theeuwes | 5,466,233 A | 11/1995 | Weiner et al. |
| 3,995,635 A | 12/1976 | Higuchi et al. | 5,476,448 A | 12/1995 | Urich |
| 4,008,719 A | 2/1977 | Theeuwes et al. | 5,476,511 A | 12/1995 | Gwon et al. |
| 4,014,333 A | 3/1977 | McIntyre | 5,554,132 A | 9/1996 | Straits et al. |
| 4,014,334 A | 3/1977 | Theeuwes et al. | 5,562,915 A | 10/1996 | Lowe et al. |
| 4,014,335 A | 3/1977 | Arnold | 5,578,042 A | 11/1996 | Cumming |
| 4,034,756 A | 7/1977 | Higuchi et al. | 5,674,193 A | 10/1997 | Hayes |
| 4,034,758 A | 7/1977 | Theeuwes | 5,681,572 A | 10/1997 | Seare, Jr. |
| 4,077,407 A | 3/1978 | Theeuwes et al. | 5,725,493 A | 3/1998 | Avery et al. |
| 4,111,201 A | 9/1978 | Theeuwes | 5,755,684 A | 5/1998 | Chen |
| 4,111,203 A | 9/1978 | Theeuwes | 5,766,242 A | 6/1998 | Wong et al. |
| 4,135,514 A | 1/1979 | Zaffaroni et al. | 5,770,076 A | 6/1998 | Chu et al. |
| 4,160,452 A | 7/1979 | Theeuwes | 5,773,019 A | 6/1998 | Ashton et al. |
| 4,164,559 A | 8/1979 | Miyata et al. | 5,792,099 A | 8/1998 | DeCamp et al. |
| 4,179,497 A | 12/1979 | Cohen et al. | 5,797,898 A | 8/1998 | Santini, Jr. et al. |
| 4,186,184 A | 1/1980 | Zaffaroni | 5,807,581 A | 9/1998 | Rosenblatt et al. |
| 4,200,098 A | 4/1980 | Ayer et al. | 5,817,075 A | 10/1998 | Giungo |
| 4,220,152 A | 9/1980 | Dresback | 5,824,072 A | 10/1998 | Wong |
| 4,220,153 A | 9/1980 | Dresback | 5,830,173 A | 11/1998 | Avery et al. |
| 4,256,108 A | 3/1981 | Theeuwes | 5,830,546 A | 11/1998 | Ehret et al. |
| 4,298,000 A | 11/1981 | Thill et al. | 5,836,935 A | 11/1998 | Ashton et al. |
| 4,300,557 A | 11/1981 | Refojo et al. | 5,868,697 A | 2/1999 | Richter et al. |
| 4,309,776 A | 1/1982 | Berguer | 5,902,598 A | 5/1999 | Chen et al. |
| 4,326,525 A | 4/1982 | Swanson et al. | 5,916,584 A | 6/1999 | O'Donoghue et al. |
| 4,327,725 A | 5/1982 | Cortese et al. | 5,928,662 A | 7/1999 | Phillips |
| 4,343,787 A | 8/1982 | Katz | 5,951,512 A | 9/1999 | Dalton |
| 4,439,196 A | 3/1984 | Higuchi | 5,968,008 A | 10/1999 | Grams |
| 4,439,198 A | 3/1984 | Brightman, II et al. | 5,972,369 A | 10/1999 | Roorda et al. |
| 4,475,916 A | 10/1984 | Himmelstein | 5,985,328 A | 11/1999 | Chu et al. |
| 4,484,922 A | 11/1984 | Rosenwald | 6,001,386 A | 12/1999 | Ashton et al. |
| 4,519,801 A | 5/1985 | Edgren | 6,123,861 A | 9/2000 | Santini, Jr. et al. |
| 4,609,374 A | 9/1986 | Ayer | 6,196,993 B1 | 3/2001 | Cohan et al. |
| 4,627,850 A | 12/1986 | Deters et al. | 6,251,090 B1 | 6/2001 | Avery et al. |
| 4,634,418 A | 1/1987 | Binder | 6,303,290 B1 | 10/2001 | Liu et al. |
| 4,634,427 A | 1/1987 | Hannula et al. | 6,331,313 B1 | 12/2001 | Wong et al. |
| 4,673,405 A | 6/1987 | Guittard et al. | 6,331,523 B1 | 12/2001 | Kljavin et al. |
| 4,693,886 A | 9/1987 | Ayer | 6,375,972 B1 | 4/2002 | Guo et al. |
| 4,712,550 A | 12/1987 | Sinnett | 6,395,300 B1 | 5/2002 | Straub et al. |
| 4,730,013 A | 3/1988 | Bondi et al. | 6,413,540 B1 | 7/2002 | Yaacobi |
| 4,737,150 A | 4/1988 | Baeumle et al. | 6,416,777 B1 | 7/2002 | Yaacobi |
| 4,774,091 A | 9/1988 | Yamahira et al. | 6,420,399 B1 | 7/2002 | Graff et al. |
| 4,777,049 A | 10/1988 | Magruder et al. | 6,468,264 B1 | 10/2002 | Gillis et al. |
| 4,781,675 A | 11/1988 | White | 6,472,162 B1 | 10/2002 | Coelho et al. |
| 4,851,228 A | 7/1989 | Zentner et al. | 6,605,066 B1 | 8/2003 | Gravagna et al. |
| 4,853,229 A | 8/1989 | Theeuwes | 6,620,139 B1 | 9/2003 | Plicchi et al. |
| 4,863,457 A | 9/1989 | Lee | 6,663,668 B1 | 12/2003 | Chaouk et al. |
| 4,865,846 A | 9/1989 | Kaufman | 6,669,950 B2 | 12/2003 | Yaacobi |
| 4,883,459 A | 11/1989 | Calderon | 6,685,940 B2 | 2/2004 | Andya et al. |
| 4,959,217 A | 9/1990 | Sanders et al. | 6,695,821 B1 | 2/2004 | Sjaarda |
| 4,979,938 A | 12/1990 | Stephen et al. | 6,713,081 B2 | 3/2004 | Robinson et al. |
| 5,049,142 A | 9/1991 | Herrick et al. | 6,719,750 B2 | 4/2004 | Varner et al. |
| 5,053,030 A | 10/1991 | Herrick et al. | 6,740,077 B1 | 5/2004 | Brandau et al. |
| 5,084,021 A | 1/1992 | Baldwin | 6,756,049 B2 | 6/2004 | Brubaker et al. |
| 5,098,443 A | 3/1992 | Parel et al. | 6,756,058 B2 | 6/2004 | Brubaker et al. |
| 5,128,145 A | 7/1992 | Edgren et al. | 6,869,412 B2 | 3/2005 | Ross |
| 5,141,748 A | 8/1992 | Rizzo | 6,932,983 B1 | 8/2005 | Straub et al. |
| 5,147,647 A | 9/1992 | Darougar | 6,976,982 B2 | 12/2005 | Santini, Jr. et al. |
| 5,164,188 A | 11/1992 | Wong | 6,986,900 B2 | 1/2006 | Yaacobi |
| 5,171,270 A | 12/1992 | Herrick | 7,026,329 B2 | 4/2006 | Crain et al. |
| 5,174,999 A | 12/1992 | Magruder et al. | 7,074,426 B2 | 7/2006 | Kochinke |
| 5,238,687 A | 8/1993 | Magruder et al. | 7,077,848 B1 | 7/2006 | de Juan, Jr. et al. |
| 5,273,530 A | 12/1993 | del Cerro et al. | 7,090,681 B2 | 8/2006 | Weber et al. |
| 5,277,912 A | 1/1994 | Lowe et al. | 7,094,222 B1 | 8/2006 | Siekas et al. |
| | | | 7,094,226 B2 | 8/2006 | Yaacobi |
| | | | 7,117,870 B2 | 10/2006 | Prescott |
| | | | 7,141,023 B2 | 11/2006 | Diermann et al. |
| | | | 7,141,152 B2 | 11/2006 | Le Febre |

(56)

References Cited

U.S. PATENT DOCUMENTS

2012/0296423 A1 11/2012 Caffey et al.
 2013/0165860 A1 6/2013 Doud et al.
 2013/0204209 A1 8/2013 de Juan, Jr. et al.
 2013/0218081 A1 8/2013 Roth
 2013/0245544 A1 9/2013 de Juan, Jr. et al.
 2013/0245573 A1 9/2013 de Juan, Jr. et al.
 2013/0274691 A1 10/2013 de Juan, Jr. et al.
 2013/0274692 A1 10/2013 Alster et al.
 2013/0304031 A1 11/2013 Varner et al.
 2013/0324918 A1 12/2013 de Juan, Jr. et al.
 2013/0324942 A1 12/2013 de Juan, Jr. et al.
 2013/0338564 A1 12/2013 Rickard et al.
 2014/0031769 A1 1/2014 de Juan, Jr. et al.
 2014/0033800 A1 2/2014 Farinas et al.
 2014/0073714 A1 3/2014 Reich et al.
 2014/0121609 A1 5/2014 de Juan, Jr. et al.
 2014/0221941 A1 8/2014 Erickson et al.
 2014/0243795 A1 8/2014 Varner et al.
 2014/0276482 A1 9/2014 Astafieva et al.
 2014/0296800 A1 10/2014 Erickson et al.
 2014/0358125 A1 12/2014 de Juan, Jr. et al.
 2015/0080846 A1 3/2015 de Juan, Jr. et al.
 2015/0250647 A1 9/2015 de Juan, Jr. et al.
 2015/0297402 A1 10/2015 de Juan, Jr. et al.
 2016/0038488 A1 2/2016 Horvath et al.
 2016/0101046 A1 4/2016 Reich et al.
 2016/0128867 A1 5/2016 Bachelder et al.
 2016/0184134 A1 6/2016 Varner et al.
 2016/0258855 A1 9/2016 Farinas et al.
 2016/0302965 A1 10/2016 Erickson et al.
 2017/0087016 A1 3/2017 Camras
 2017/0165108 A1 6/2017 Bianchi et al.
 2017/0165110 A1 6/2017 Erickson et al.
 2017/0172794 A1 6/2017 Varner et al.
 2017/0258634 A1 9/2017 de Juan, Jr. et al.
 2018/0147204 A1 5/2018 Horvath et al.
 2018/0161202 A1 6/2018 de Juan, Jr. et al.
 2018/0243130 A1 8/2018 Doud et al.
 2018/0243131 A1 8/2018 Erickson et al.
 2018/0289542 A1 10/2018 de Juan, Jr. et al.
 2018/0292403 A1 10/2018 de Juan, Jr. et al.
 2019/0117454 A1 4/2019 Campbell et al.
 2019/0336335 A1 11/2019 de Juan, Jr. et al.
 2019/0350754 A1 11/2019 Bianchi et al.
 2019/0365757 A1 12/2019 Horvath et al.
 2020/0030142 A1 1/2020 Erickson et al.
 2020/0060874 A1 2/2020 Bachelder et al.
 2020/0107955 A1 4/2020 Erickson et al.
 2020/0337897 A1 10/2020 Sacherman et al.
 2021/0205130 A1 7/2021 Campbell et al.
 2022/0087863 A1 3/2022 Bachelder et al.
 2023/0181829 A1* 6/2023 Goldenberg A61D 7/00
 604/183

FOREIGN PATENT DOCUMENTS

CN 102112076 A 6/2011
 CN 204600878 U 9/2015
 CN 105979985 A 9/2016
 CN 106413642 A 2/2017
 CN 305838524 S 6/2020
 EP 0033042 B1 8/1984
 EP 0 228 185 A1 11/1986
 EP 0498471 8/1992
 EP 0500143 8/1992
 EP 0295248 3/1993
 EP 0671165 9/1995
 EP 0944658 B1 6/2003
 EP 1671624 6/2006
 EP 1385452 9/2006
 EP 1409065 1/2007
 EP 1337284 B1 12/2007
 EP 1911481 4/2008
 EP 1521572 B1 3/2009

JP 01-149716 6/1989
 JP 01-197429 A 8/1989
 JP 2001-518880 A 10/2001
 JP 2004-516889 A 6/2004
 JP D1739057 * 3/2023
 TW M577313 U 5/2019
 WO WO-88/04573 6/1988
 WO WO-90/07545 7/1990
 WO WO-94/24969 A1 11/1994
 WO WO-95/28984 A1 11/1995
 WO WO-97/29850 8/1997
 WO WO-98/25982 6/1998
 WO WO-98/43611 A1 10/1998
 WO WO-99/11244 3/1999
 WO WO-00/48660 8/2000
 WO WO-01/26714 4/2001
 WO WO-01/50943 7/2001
 WO WO-01/68016 A2 9/2001
 WO WO-02/053128 A2 7/2002
 WO WO-02/100318 12/2002
 WO WO-03/028765 4/2003
 WO WO-03/077972 9/2003
 WO WO-03/082188 10/2003
 WO WO-2004/000267 12/2003
 WO WO-2004/112653 12/2004
 WO WO-2005/016401 2/2005
 WO WO-2005/025413 A2 3/2005
 WO WO-2005/027906 3/2005
 WO WO-2005/028006 3/2005
 WO WO-2005/091922 10/2005
 WO WO-2005/107705 11/2005
 WO WO-2005/110362 11/2005
 WO WO-2005/110436 11/2005
 WO WO-2005/110473 11/2005
 WO WO-2005/117780 12/2005
 WO WO-2006/014484 2/2006
 WO WO-2006/015385 2/2006
 WO WO-2006/023530 3/2006
 WO WO-2006/031358 3/2006
 WO WO-2006/031388 3/2006
 WO WO-2006/044614 4/2006
 WO WO-2006/050221 5/2006
 WO WO-2006/068838 6/2006
 WO WO-2006/071554 7/2006
 WO WO-2006/082588 A2 8/2006
 WO WO-2006/108054 10/2006
 WO WO-2006/127962 11/2006
 WO WO-2006/138609 12/2006
 WO WO-2007/012974 2/2007
 WO WO-2007/035473 3/2007
 WO WO-2007/035621 3/2007
 WO WO-2007/038453 4/2007
 WO WO-2007/044534 4/2007
 WO WO-2007/047744 4/2007
 WO WO-2007/066339 6/2007
 WO WO-2007/084582 7/2007
 WO WO-2007/084765 7/2007
 WO WO-2007/101204 9/2007
 WO WO-2007/115259 A2 10/2007
 WO WO-2007/117394 10/2007
 WO WO-2007/131050 11/2007
 WO WO-2007/133761 11/2007
 WO WO-2007/133762 11/2007
 WO WO-2008/003043 1/2008
 WO WO-2008/005240 1/2008
 WO WO-2008/011125 1/2008
 WO WO-2008/019265 A2 2/2008
 WO WO-2008/033924 3/2008
 WO WO-2008/040062 4/2008
 WO WO-2008/045272 4/2008
 WO WO-2008/052145 5/2008
 WO WO-2008/060359 5/2008
 WO WO-2008/061043 5/2008
 WO WO-2008076544 6/2008
 WO WO-2008/094989 A2 8/2008
 WO WO-2008/115290 9/2008
 WO WO-2008/116165 9/2008
 WO WO-2008/144340 11/2008
 WO WO-2008/144919 12/2008

(56)

References Cited

FOREIGN PATENT DOCUMENTS

| | | |
|----|-------------------|---------|
| WO | WO-2009/012075 | 1/2009 |
| WO | WO-2009/023615 | 2/2009 |
| WO | WO-2009/046164 | 4/2009 |
| WO | WO-2009/055620 | 4/2009 |
| WO | WO-2009/055671 | 4/2009 |
| WO | WO-2009/055729 | 4/2009 |
| WO | WO-2009/055824 | 4/2009 |
| WO | WO-2009/061607 | 5/2009 |
| WO | WO-2009/073192 | 6/2009 |
| WO | WO-2009/086112 | 7/2009 |
| WO | WO-2009/089409 | 7/2009 |
| WO | WO-2009/094466 | 7/2009 |
| WO | WO-2009/112878 | 9/2009 |
| WO | WO-2009/117112 | 9/2009 |
| WO | WO-2009/124096 | 10/2009 |
| WO | WO-2009/128932 | 10/2009 |
| WO | WO-2009/134929 | 11/2009 |
| WO | WO-2009/137777 | 11/2009 |
| WO | WO-2009/137780 A2 | 11/2009 |
| WO | WO-2010/008424 | 1/2010 |
| WO | WO-2010/021993 | 2/2010 |
| WO | WO-2010/047753 | 4/2010 |
| WO | WO-2010/062628 | 6/2010 |
| WO | WO-2010/066714 | 6/2010 |
| WO | WO-2010/075565 | 7/2010 |
| WO | WO-2010/078063 | 7/2010 |
| WO | WO-2010/088548 A1 | 8/2010 |
| WO | WO-2010/093945 | 8/2010 |
| WO | WO-2010/095940 | 8/2010 |
| WO | WO-2010/125416 | 11/2010 |
| WO | WO-2010/126908 | 11/2010 |
| WO | WO-2010/135369 | 11/2010 |
| WO | WO-2010/141729 | 12/2010 |
| WO | WO-2010/147661 | 12/2010 |
| WO | WO-2011/008896 | 1/2011 |
| WO | WO-2011/008897 | 1/2011 |
| WO | WO-2011/028850 | 3/2011 |
| WO | WO-2011/034627 | 3/2011 |
| WO | WO-2011/079232 | 6/2011 |
| WO | WO-2012/019047 A2 | 2/2012 |
| WO | WO-2012/019136 A2 | 2/2012 |
| WO | WO-2012/065006 A2 | 5/2012 |
| WO | WO-2013/003620 | 1/2013 |
| WO | WO-2013/022801 | 2/2013 |
| WO | WO-2013/040247 A2 | 3/2013 |
| WO | WO-2013/151904 A1 | 10/2013 |
| WO | WO-2017/087902 A1 | 5/2017 |

OTHER PUBLICATIONS

Inox Ophthalmic Needles, Inox, [Post date: Jun. 16, 2021], [Site seen Nov. 15, 2023], Seen at URL: <https://www.t-injecta.sk/en/needles/inox-ophthalmic-needles> (Year: 2021).*

Susvimo Ordering Guide, Genentech, [post date unknown], [Site seen: Nov. 6, 2023], Seen at URL: <https://www.susvimo-hcp.com/content/dam/gene/susvimo-hcp/pdfs/physician-and-staff-ordering-guide.pdf> (Year: 2023).*

“Juvederm”, FDA, 2006, XP002670727, Retrieved from the Internet: URL:http://www.accessdata.fda.gov/cdrh_docs/pdf5/P050047b.pdf [retrieved on Mar. 1, 2012] p. 1, last paragraph.

“MABPac SCX-10 Column for Monoclonal Antibody Variant Analysis.” *Dionex*. Aug. 2010. [<http://www.dionex.com/en-us/webdocs/87008-DS-MABPac-SCX-10-Column-20Aug2010-LPN2567-03.pdf>]. Web. Retrieved May 2012. 4 pages.

Andrews, “Effect of nonsteroidal anti-inflammatory drugs on LFA-1 and ICAM-1 expression in gastric mucosa,” *Am J Physiol*. Apr. 1994;266(4 Pt 1):G657-664.

Arvo, Agenda for the Summer Eye Research Conference, (Jul. 2009). 7 pages.

Avery et al., “Intravitreal bevacizumab (Avastin) in the treatment of proliferative diabetic retinopathy,” *Ophthalmology*. Oct. 2006, 113(10):1695-1705.e6.

Bakri et al., “The effect of intravitreal triamcinolone acetonide on intraocular pressure,” *Ophthalmic Surgery, Lasers and Imaging*, Sep./Oct. 2003; 34(5): 386-390.

Bantseev, V. (2021). “Nonclinical Toxicology and Biocompatibility Program Supporting Clinical Development and Registration of the Port Delivery System With Ranibizumab for Neovascular Age-Related Macular Degeneration.” *Toxicologic Pathology*, 49(3), 663-672. <https://doi.org/10.1177/0192623320968079>.

Bird et al., *Transport Phenomena*, John Wiley & Sons, Inc., New York, 1960, pp. 196-201.

Block et al., “Solubility and dissolution of triamcinolone acetonide,” *Journal of Pharmaceutical Sciences*, Apr. 1973; 62(4):617-621.

Breslin, C.W., et al., “Chapter 7. Slow Release Artificial Tears”, *Symposium on Ocular Therapy* pp. 77-83, 1977.

Carbonaro, et al. “Nano-pore silicon membrane characterization by diffusion and electrical resistance.” *Journal of Membrane Science*. 241 (2004):249-255.

Castro et al., “Effect of COX inhibitors on VEGF-induced retinal vascular leakage and experimental corneal and choroidal neovascularization,” *Exp Eye Res*. Aug. 2004;79(2):275-285.

Chirila et al., “The Vitreous Humor” in *Handbook of Biomaterial Properties*, eds. Black & Hastings. Chapman & Hall, London, 1998; pp. 125-131.

Cousins et al., “Program # 1251—Targeting Complement Factor 5 in Combination with Vascular Endothelial Growth Factor (VEGF) Inhibition for Neovascular Age Related Macular Degeneration (AMD): Results of a Phase 1 Study,” [Presentation Abstract], AMD Clinical Trials Session # 220, May 3, 2010. 2 pages.

Deissler et al., “VEGF-induced effects on proliferation, migration and tight junctions are restored by ranibizumab (Lucentis) in microvascular retinal endothelial cells,” *Br J Ophthalmol* 2008;92:839-843.

Del Amo, et al., *Current & future ophthalmic drug delivery systems . . .*, Drug Discovery Today, vol. 13, Nos. 3/4, Feb. 2008:135-143.

Donoso et al., “The role of inflammation in the pathogenesis of age-related macular degeneration,” *Surv Ophthalmol*. Mar.-Apr. 2006;51(2):137-52.

Duvvuri et al., *Drug Delivery to the Retina: Challenges and Opportunities*, *Expert Opinion on Biological Therapy*, 2003, vol. 3(1):45-56.

European Medicine Agency, Scientific Discussion; retrieved from the Internet; <http://www.ema.europa.eu/docs/en_GB/document_library/EPAR_Scientific_Discussion/human/000715/WC500043550.pdf>, EMEA 2007, 54 pages total. 2007.

Funatsu et al. “Association of vitreous inflammatory factors with diabetic macular edema,” *Ophthalmology* 2009;116:73-79.

Gaudana et al., *Recent Perspectives in Ocular Drug Delivery*, *Pharmaceutical Research*, 2008. 20 pages.

Gaudreault et al., “Preclinical Pharmacokinetics of Ranibizumab (rhuFabV2) after a Single Intravitreal Administration,” *Investigative Ophthalmology and Visual Science*. 2005;46:726-733. Retrieved from the Internet: <<<http://www.iovs.org/cgi/reprint/46/2/726>>>.

Genentech. (2021). *Susvimo: Highlights of Prescribing Information*. South San Francisco, CA: Genentech Inc. 31 pages.

Genentech. (2021). *Susvimo: Medication Guide*. South San Francisco, CA: Genentech Inc. 3 pages.

Gillies et al., “Intravitreal triamcinolone for refractory diabetic macular edema: two-year results of a double-masked, placebo-controlled, randomized clinical trial,” *Ophthalmology*. Sep. 2006;113(9):1533-1538.

Haller, *An Overview of Sustained-release Drug Implants*, *Retinal Physician*, Jan. 2008. 4 pages.

Hastedt & Wright, “Diffusion in porous materials above the percolation threshold,” *Pharm. Res*. Sep. 1990; 7(9):893-901 (1990).

Heier et al., “Ketorolac versus prednisolone versus combination therapy in the treatment of acute pseudophakic cystoid macular edema,” *Ophthalmology*. Nov. 2000;107(11):2034-2038, discussion 2039.

Janoria, KG et al. (2007). “Novel Approaches to Retinal Drug Delivery,” *Expert Opinion Drug Delivery*, 4(4): 371-388.

Jena et al., “A Novel Technique for Surface Area and Particle Size Determination of Components of Fuel Cells and Batteries,” *Porous Materials, Inc.*, Dec. 2006, 3 pages total. Downloaded from the

(56)

References Cited

OTHER PUBLICATIONS

Internet: <<http://www.pmiapp.com/publications/docs/A_Novel_technique_for_surface_area.pdf>>.

Jornitz et al. "Filter Integrity Testing in Liquid Applications, Revisited; Part 1." *Pharmaceutical Technology*. Oct. 2001. pp. 34-50.

Kang et al., "Inhibitory effects of anti-inflammatory drugs on interleukin-6 bioactivity," *Biol Pharm Bull*. Jun. 2001;24(6):701-703.

Katz, I.M., et al., "A Soluble Sustained-Release Ophthalmic Delivery Unit", 8:5 (May 1977) pp. 728-734.

Lamberts, D.W., M.D., et al., "A Clinical Study of Slow-Releasing Artificial Tears", *Ophthalmology* 85 (1978) pp. 794-800.

Lee, D.A., et al., "Glaucoma Filtration Surgery in Rabbits Using Bioerodible Polymers and 5-Fluorouracil", *Ophthalmology* 94:12 (1987) pp. 1523-1530.

Lee, D.A., et al., "The Use of Bioerodible Polymers and 5-Fluorouracil in Glaucoma Filtration Surgery", *Investigative Ophthalmology & Visual Science* 29-11 (1988) pp. 1692-1697.

Li, P-Y et al., (2008). "An electrochemical introcular drug delivery device," *Science Direct, Sensors and Actuators*, pp. 41-48. www.sciencedirect.com.

Lopez-Armada et al., "Modulation of cell recruitment by anti-inflammatory agents in antigen-induced arthritis," *Ann Rheum Dis* Nov. 2002;61(11):1027-1030.

Luncentis, INN-Ranibizumab, (2010). "Scientific Discussion," European Medicines Agency, retrieved from the Internet: <http://www.ema.europa.eu/docs/en_GB/document_library/EPAR_-_Assessment_Report_-_Variation/human/000715/WC500101009.pdf>. Oct. 21, 2010. 32 pages.

Metal Powder Industries Federation, *Porous Metal Design Guidebook*, 2007, 24 pages total. Downloaded from the Internet: <<<http://www.mpif.org/DesignCenter/porous.pdf>>>.

Miller, DP, et al., *Thermophysical Properties of Trehalose and Its Concentrated Aqueous Solutions*, *Pharmaceutical Research*, vol. 14, No. 5, 1997, pp. 578-590.

Millipore. "Filter Integrity Test Methods." *Millipore Corporation*. 1999. 12 pages.

Molokhia et al., "Transscleral iontophoretic and intravitreal delivery of a macromolecule: Study of ocular distribution in vivo and postmortem with MRI", *Experimental Eye Research* 88 (2009) 418-425.

Moritera, T., et al., "Microspheres of Biodegradable Polymers as a Drug-Delivery System in the Vitreous", *Investigative Ophthalmology & Visual Science* 32-6 (1991) pp. 1785-1790.

Mott Corporation, "Sintered Metal Powder Media," *American Filtration & Separation Society* 2007, 2 pages total. Downloaded from the Internet: <<<http://www.afssociety.org/education/0907oneminute.htm>>>.

Navarro, "The Optical Design of the Human Eye: a Critical Review," *J Optom*, Jan.-Mar. 2009 2(1): 3-18.

Nutan, M.T.H. et al. (2010) "General Principles of Suspensions," Chapter 2 in *Pharmaceutical Suspensions From Formulation Development to Manufacturing*, editors AK Kulshreshtha, et al., Springer. 29 pages.

Okabe et al., "Intraocular tissue distribution of betamethasone after intrascleral administration using a non-biodegradable sustained drug delivery device," *Investigative Ophthalmology and Visual Science*. 2003;44:2702-2707. Downloaded from the Internet: <<<http://www.iovs.org/cgi/reprint/44/6/2702>>>.

Rosenfeld, "The Latest Research: Intravitreal Bevacizumab for Proliferative Diabetic Retinopathy," *Review of Ophthalmology's Retina Online*, Feb. 2006; 2 pages. Retrieved from the Internet: http://www.revophth.com/archive/newsletter/0206_retina.htm.

Saline (medicine). Wikipedia, the free encyclopedia. 2011. Web. Apr. 27, 2012. 4 pages. [http://web.archive.org/web/20110205192937/http://en.wikipedia.org/wiki/Saline_\(medicine\)](http://web.archive.org/web/20110205192937/http://en.wikipedia.org/wiki/Saline_(medicine)).

Sanborn G.E., et al. (Feb. 1992). "Sustained-Release Ganciclovir Therapy for Treatment of Cytomegalovirus Retinitis, Use of an Intravitreal Device." *Arch. Ophthalmol.* vol. 110, 188-195.

Sharma, Rajesh K., Anna T. Rogojina, and K.V. Chalam. "Bevacizumab Therapy Normalizes the Pathological Intraocular Environment beyond Neutralizing VEGF." *Molecular Vision* 16(2010): 2175-2184. Print. Sheardown and Saltzman, *Novel Drug Delivery Systems for Posterior Segment Ocular Disease, Ophthalmology: Ocular Angiogenesis: Diseases, Mechanisms and Therapeutics*, 2007, pp. 393-408.

Smith et al., "Spectrophotometric determination of pKa values for fluorescein using activity coefficient corrections," *WaterSA* 2002; 28(4):395-402.

Smith, T.J., et al. (1992). "Intravitreal Sustained-Release Ganciclovir," *Arch. Ophthalmol.* 110, pp. 255-258.

Soheilian et al., "Pilot Study of Intravitreal Injection of Diclofenac for Treatment of Macular Edema of Various Etiologies," *Retina*, Mar. 2010; 30(3): 509-515.

Stay et al. *Computer Simulation of Convective and Diffusive Transport of Controlled-Release Drugs in the vitreous Humor*, *Pharm Res* 2003, 20(1), pp. 96-102.

Theodossiadis et al., "Intravitreal administration of the anti-tumor necrosis factor agent infliximab for neovascular age-related macular degeneration," *Am J Ophthalmol.* May 2009;147(5):825-830.

Weiner, A.L., "Chapter 13: Polymeric Drug Delivery Systems for the Eye", *Polymeric Site-Specific Pharmacotherapy*, pp. 315-346, Edited by A.J. Domb (1994) John Wiley & Sons Ltd.

Williams et al., "Treating Diabetic Macular Edema With Ocular NSAIDs," *Retinal Physician*, Nov. 2007; retrieved from the Internet Nov. 11, 2007. <http://www.retinalphysician.com/article.aspx?article=101096>, 5 pages total.

Wright, P., et al. "Slow-Release Artificial Tear Inserts in the Treatment of Dry Eyes Resulting from the Oculomucocutaneous Syndrome", *British Journal of Ophthalmology* 67 (1983) pp. 393-397.

Yao et al. (2009). "Prevention of Laser Photocoagulation Induced Choroidal Neovascularization Lesions by Intravitreal Doses of Ranibizumab in Cynomolgus Monkeys," *ARVO* 2009 abstract D906. 2 pages.

* cited by examiner

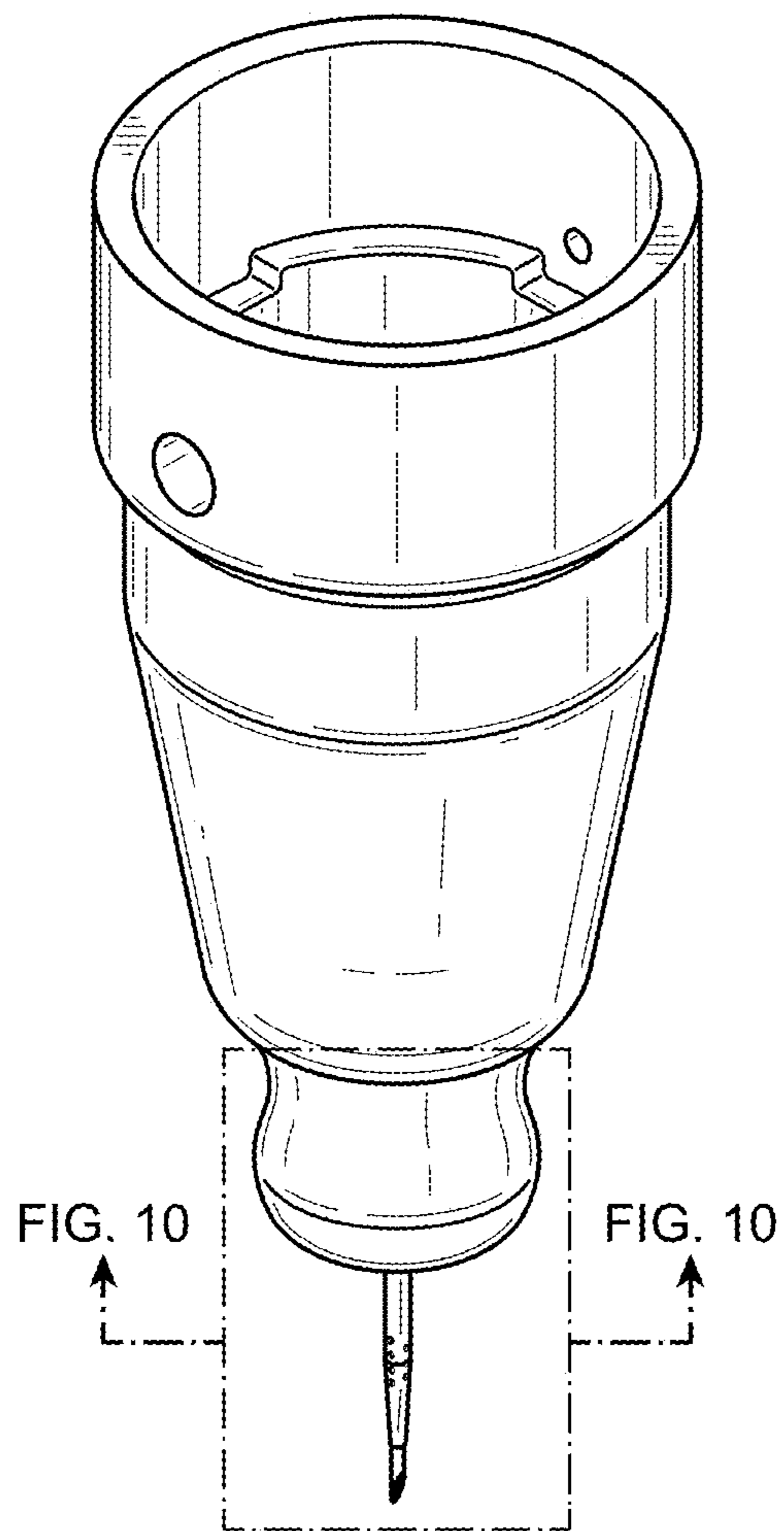

FIG. 1

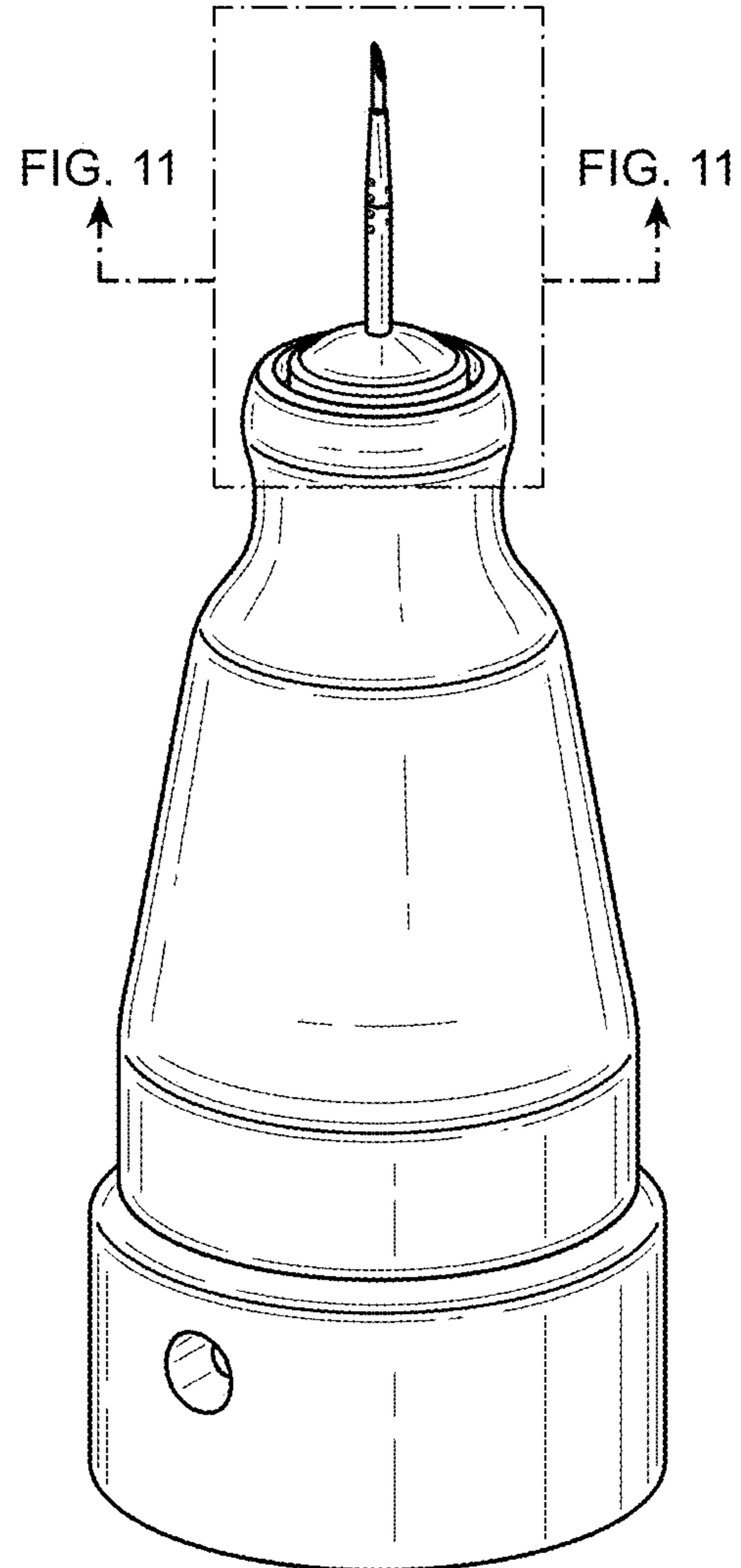

FIG. 2

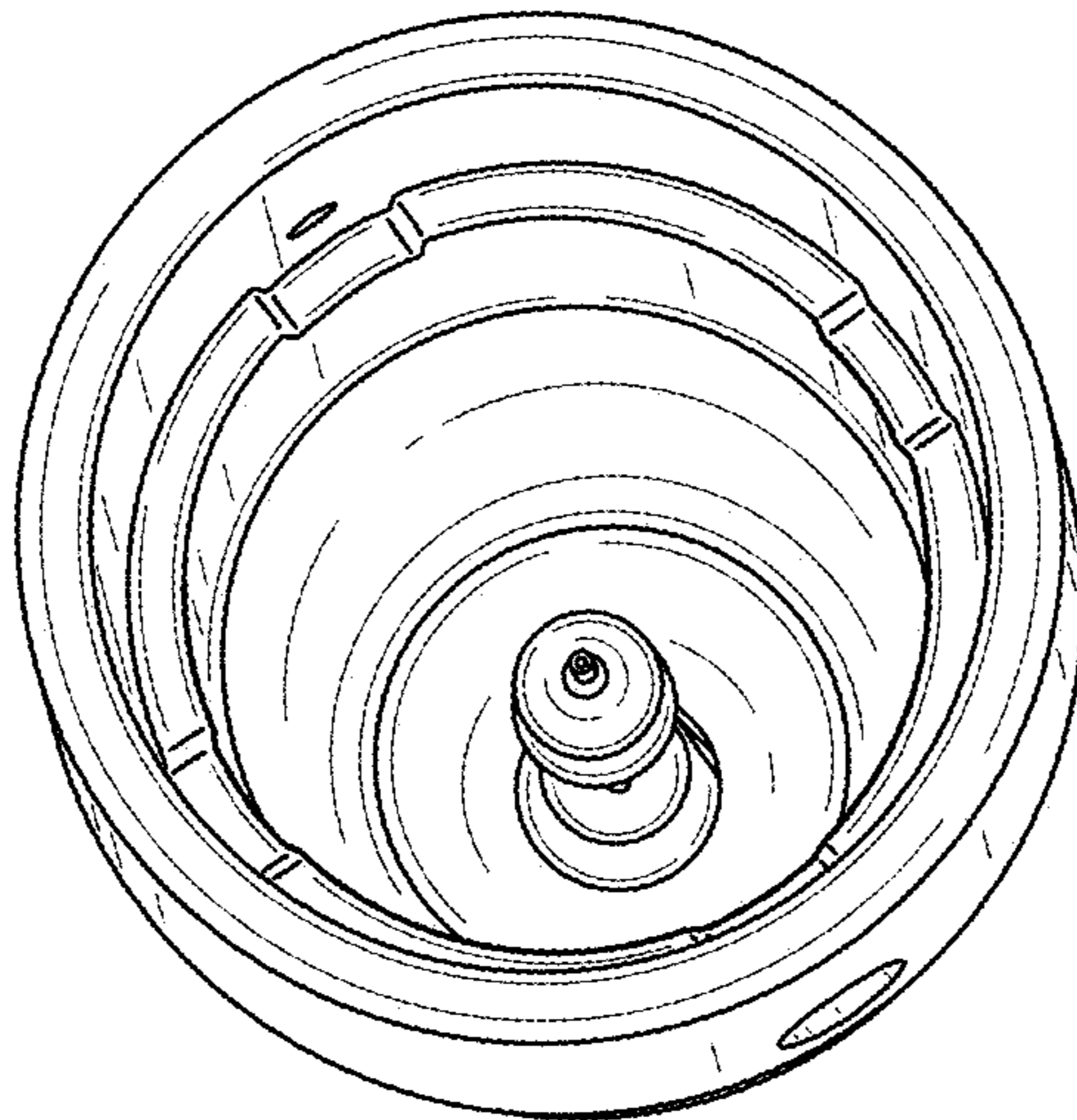

FIG. 3

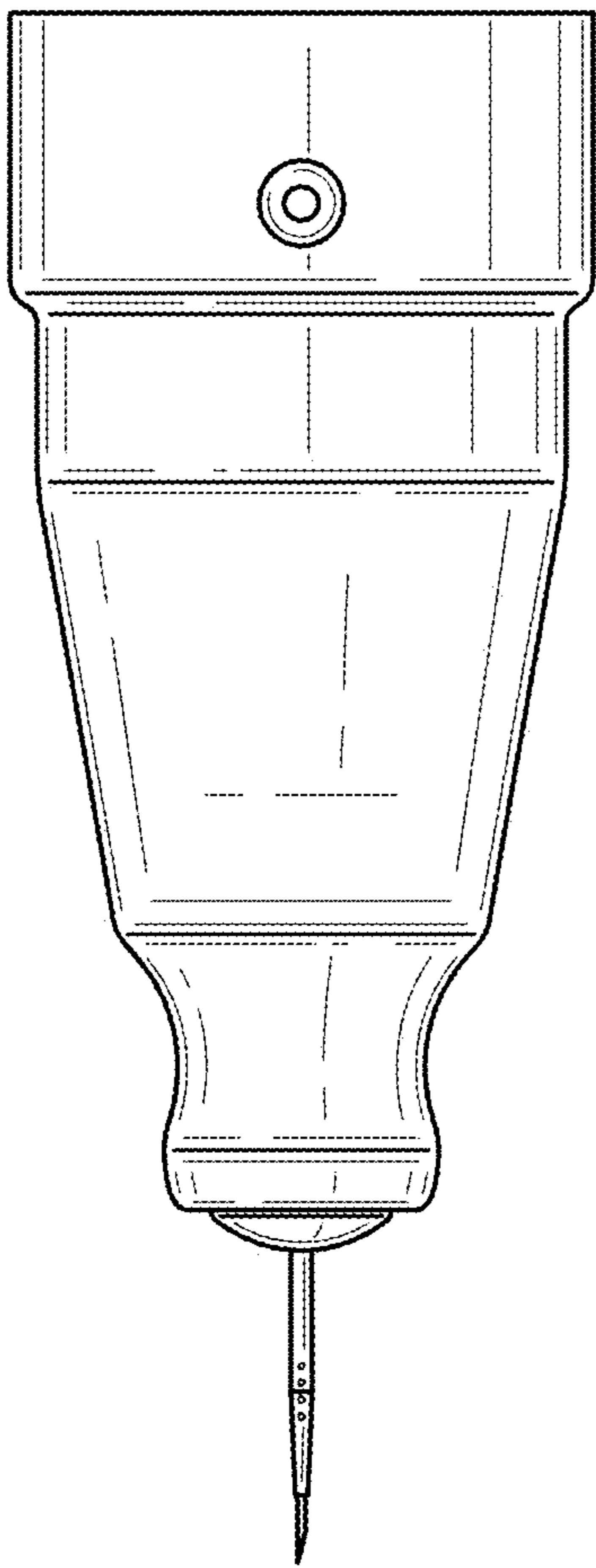

FIG. 4

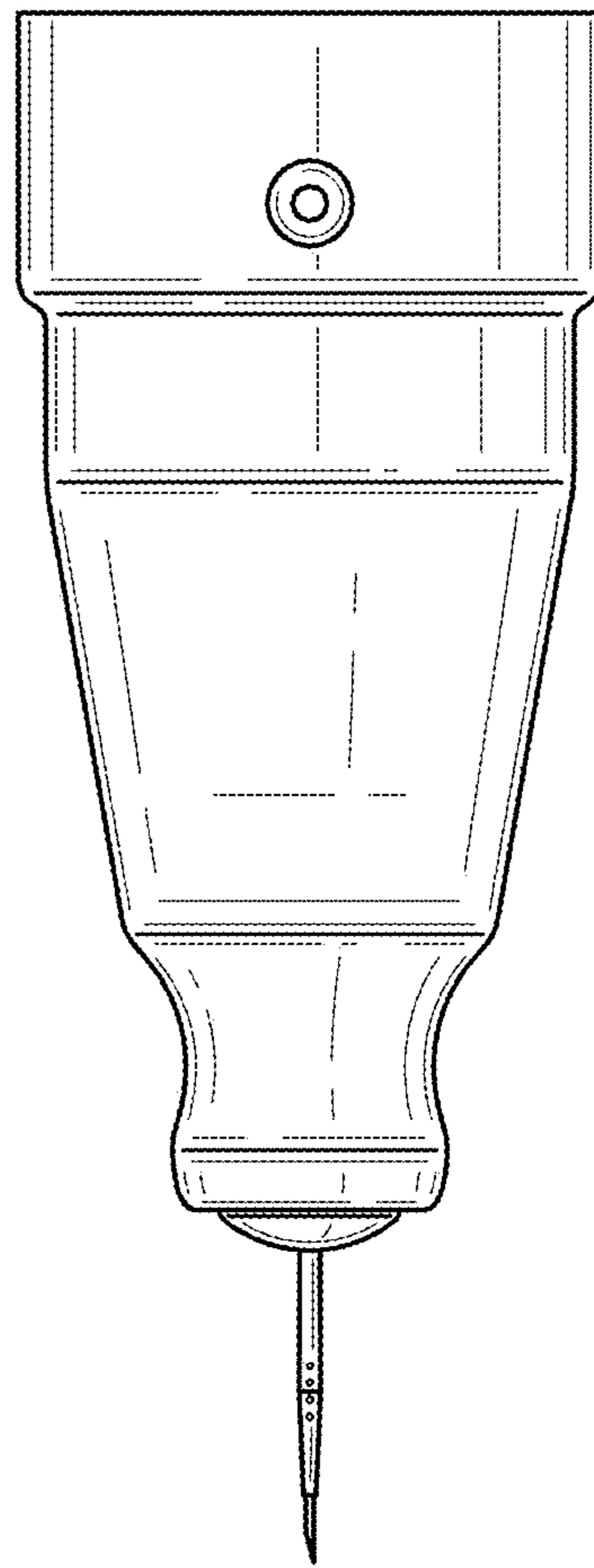

FIG. 5

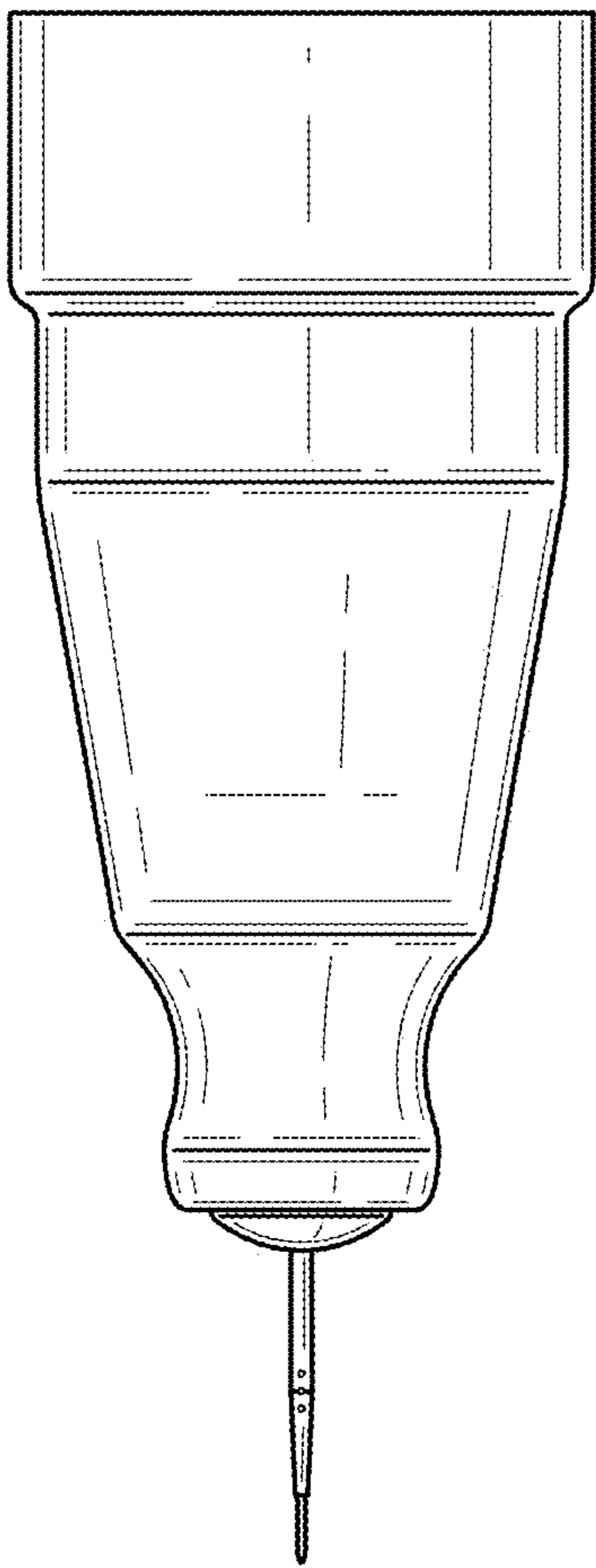

FIG. 6

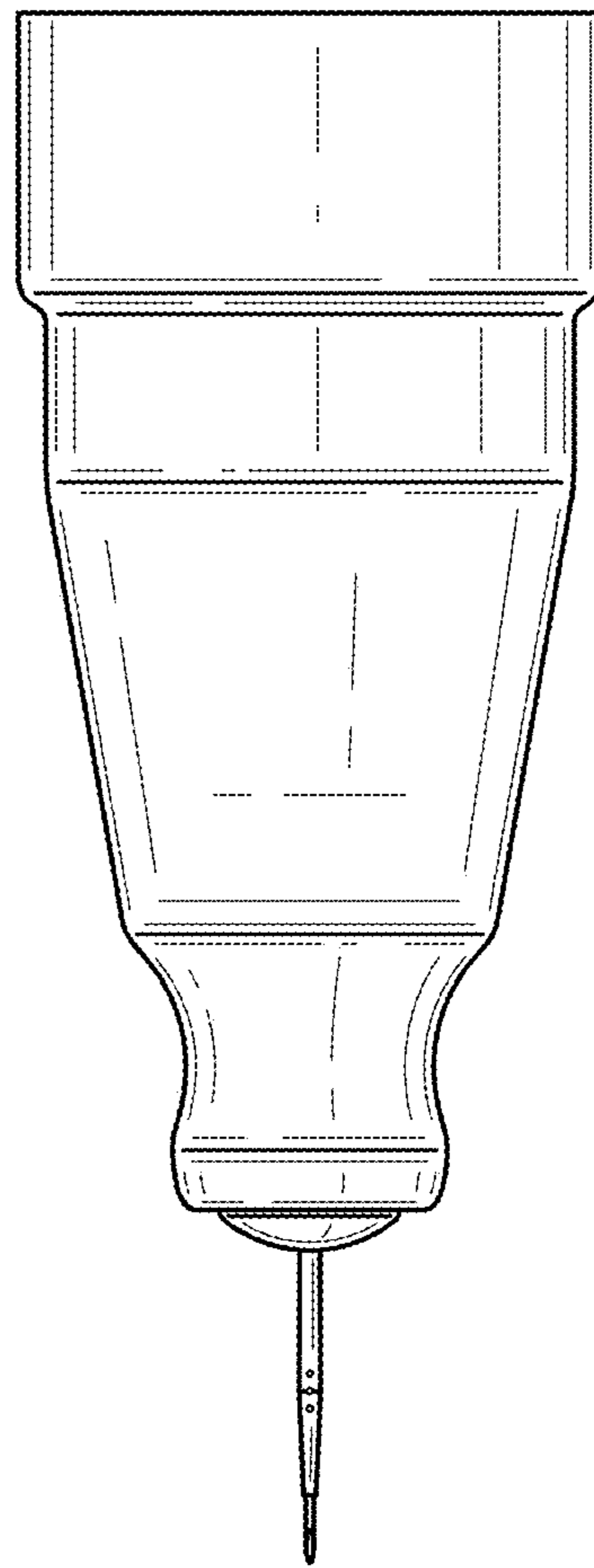

FIG. 7

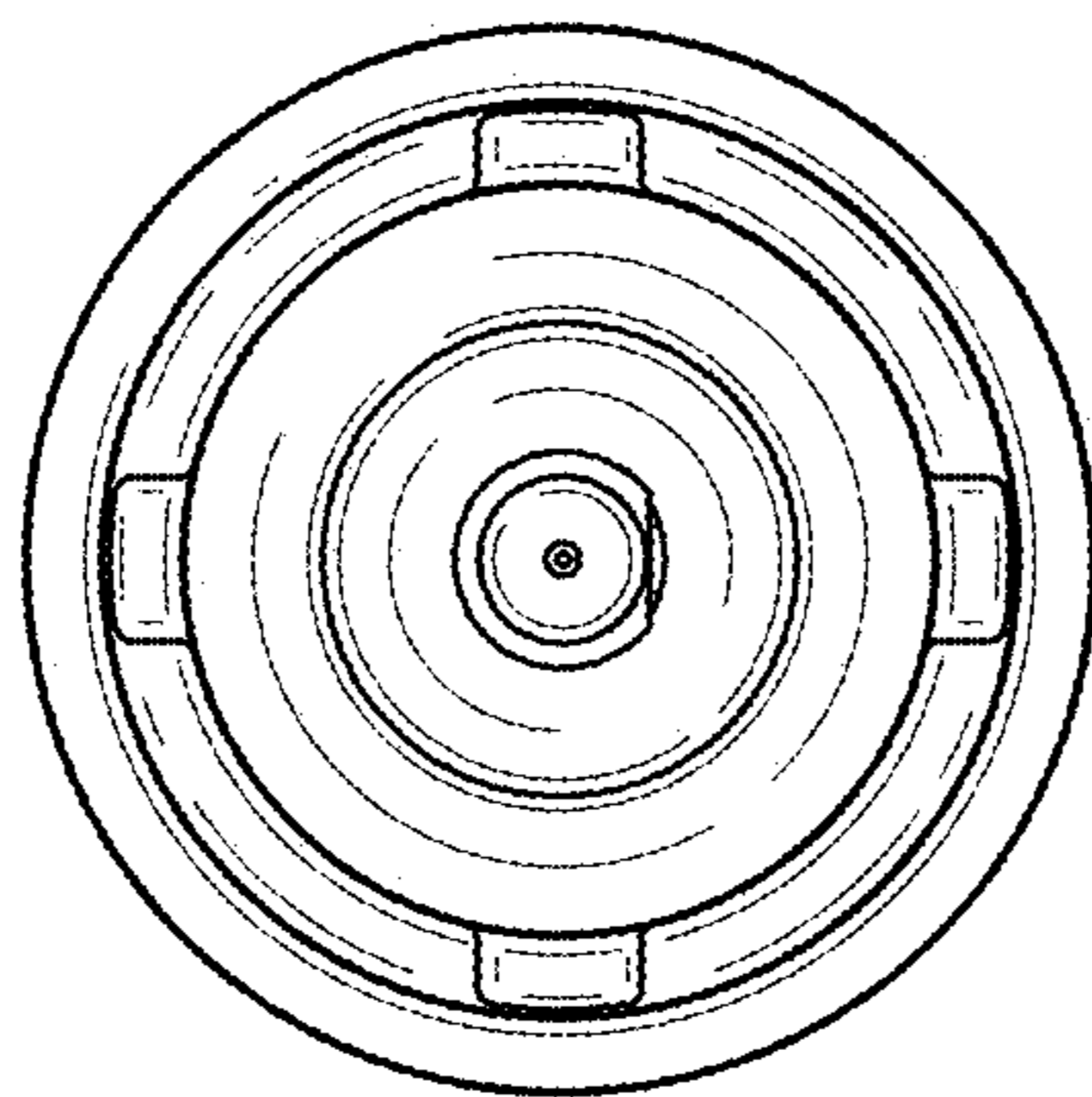

FIG. 8

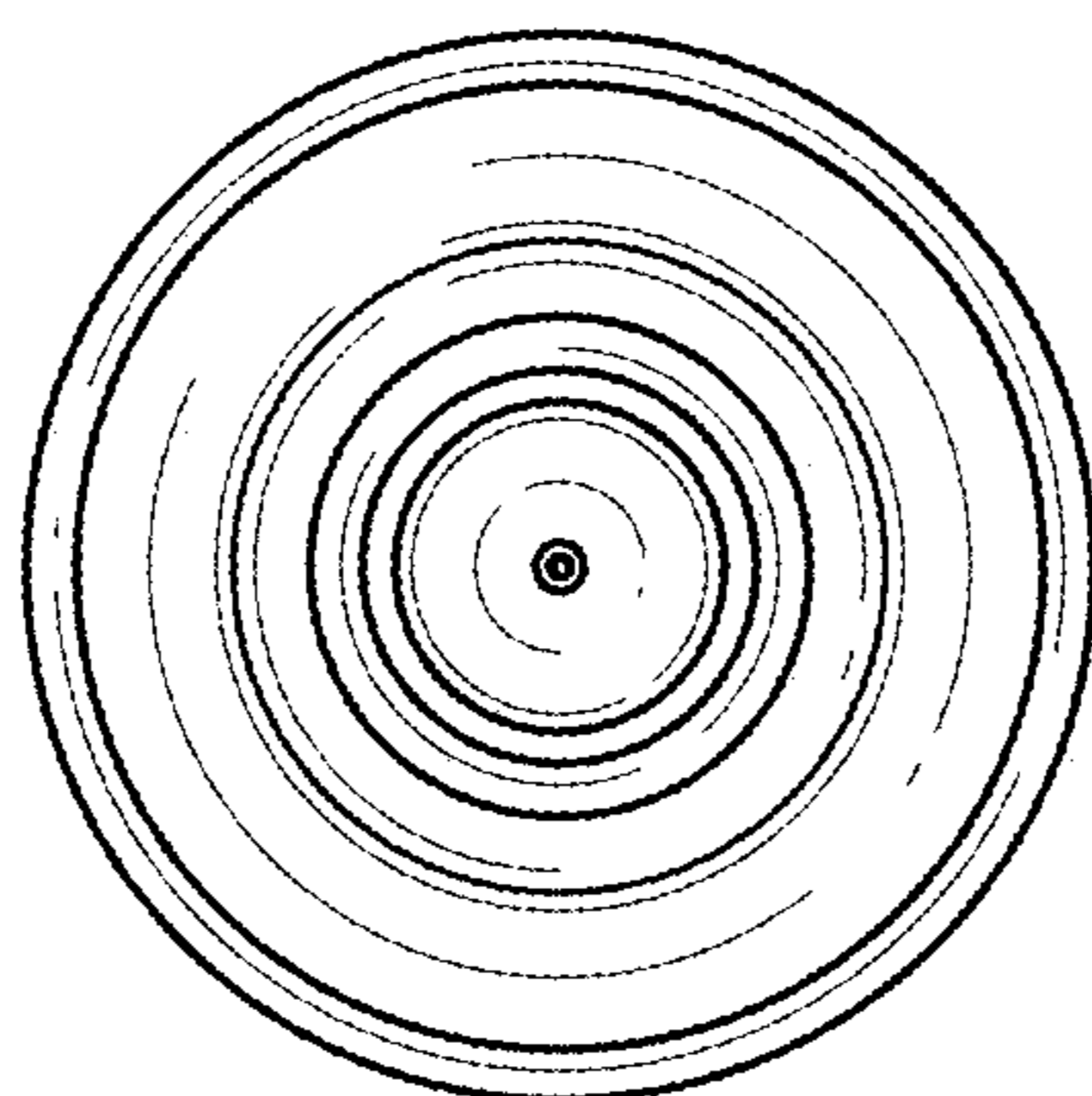

FIG. 9

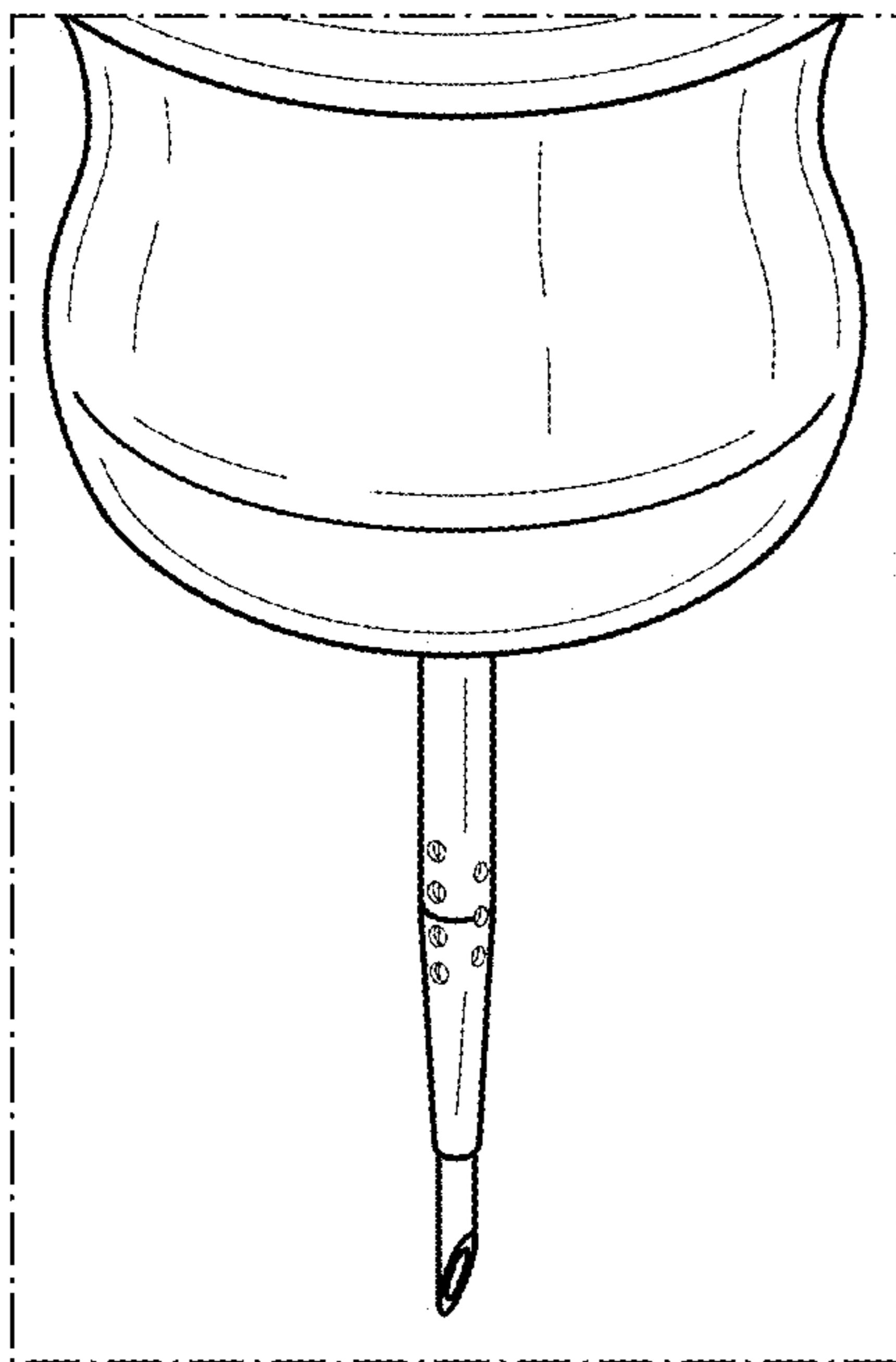

FIG. 10

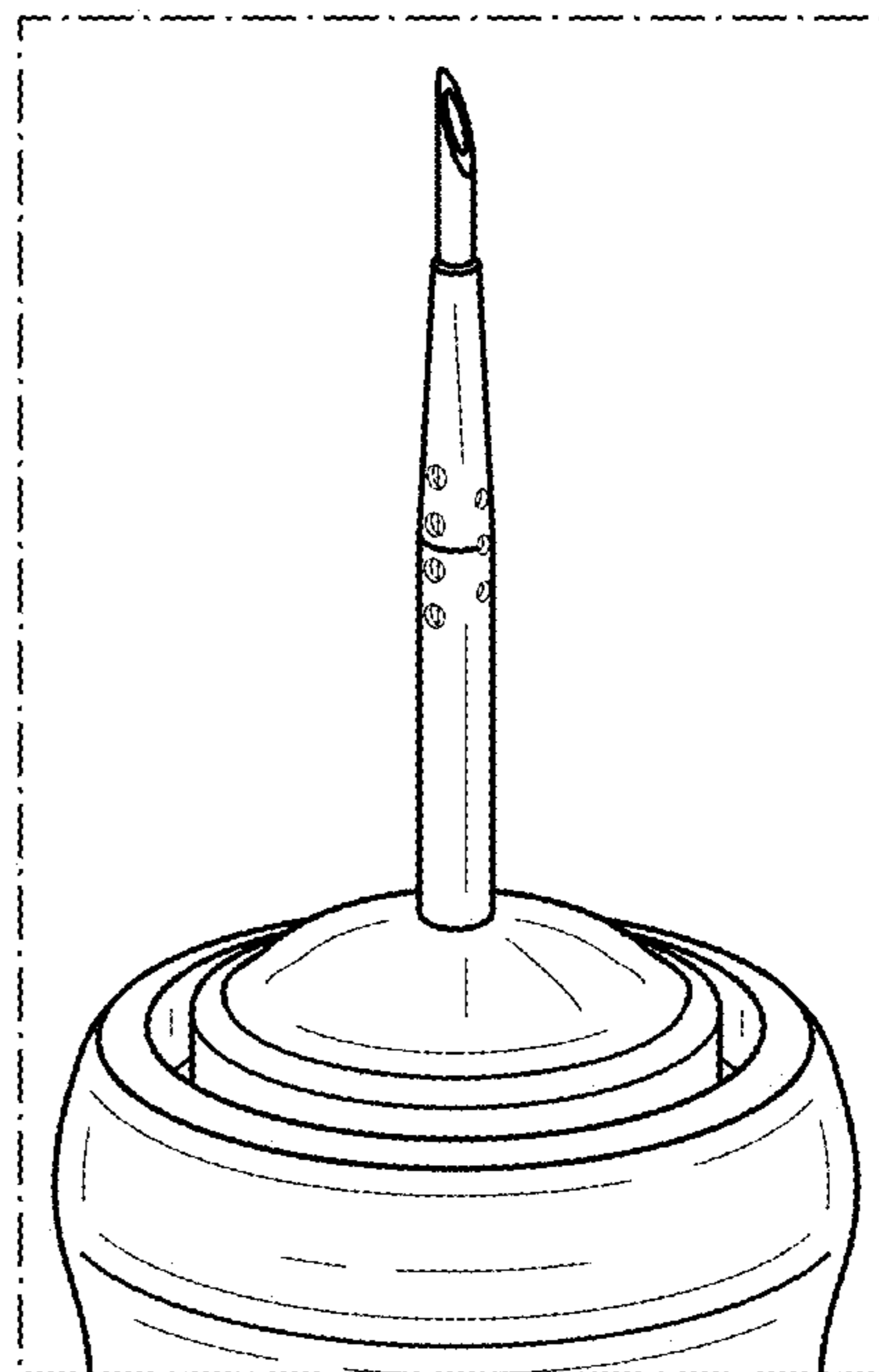

FIG. 11