



US0D1032437S

(12) **United States Design Patent** (10) **Patent No.:** **US D1,032,437 S**
Acton et al. (45) **Date of Patent:** **** Jun. 25, 2024**

(54) **AIR INTAKE GRILLE**
(71) Applicant: **PACCAR Inc**, Bellevue, WA (US)
(72) Inventors: **Jon Forrest Acton**, Fort Worth, TX (US); **Troy Robin McCuller**, Argyle, TX (US); **Tu Hoang Do**, Lewisville, TX (US); **Leannah Marie Nichols**, Haslet, TX (US)

D808,316 S 1/2018 Piscitelli et al.
D819,515 S 6/2018 Anderson et al.
D842,767 S 3/2019 Hjorten et al.
D854,234 S * 7/2019 Lucas D26/139
D865,601 S * 11/2019 Goodrich D12/190
D871,276 S 12/2019 Hjorten et al.
D878,986 S * 3/2020 Smith D12/181
D882,472 S 4/2020 Goodrich et al.

(Continued)

(73) Assignee: **PACCAR Inc**, Bellevue, WA (US)
(**) Term: **15 Years**

(21) Appl. No.: **29/875,874**
(22) Filed: **May 11, 2023**

Related U.S. Application Data

(62) Division of application No. 29/751,837, filed on Sep. 23, 2020, now Pat. No. Des. 993,118.
(51) **LOC (14) Cl.** **12-16**
(52) **U.S. Cl.**
USPC **D12/190**
(58) **Field of Classification Search**
USPC D12/163, 196, 86, 90, 91, 92, 169, 190, D12/98, 164
CPC B62D 25/08; B60K 11/08; B60R 19/52
See application file for complete search history.

(56) **References Cited**

U.S. PATENT DOCUMENTS

D647,829 S 11/2011 Medina et al.
D647,830 S 11/2011 Medina et al.
D708,990 S 7/2014 Conway et al.
D713,765 S 9/2014 Peltola et al.
D748,548 S 2/2016 Battams
D763,152 S 8/2016 Frascella
D800,027 S * 10/2017 Jensen D12/163
D807,264 S 1/2018 Henstridge

OTHER PUBLICATIONS

“T800,” Kenworth Truck Company, 2002, 32-page brochure.
(Continued)

Primary Examiner — Susan E Krakower
Assistant Examiner — Jerry Shiuan-Hua Hsu
(74) *Attorney, Agent, or Firm* — Seed IP Law Group LLP

(57) **CLAIM**

The ornamental design for an air intake grille, as shown and described.

DESCRIPTION

FIG. 1 is an isometric view of an air intake grille, showing our new design.
FIG. 2 is a front elevational view thereof.
FIG. 3 is a cross-sectional view of a portion of the air intake grille shown in FIG. 2, taken along line 3-3.
FIG. 4 is a rear elevational view of the air intake grille.
FIG. 5 is an isometric view of an air intake grille, showing another embodiment of our new design, which is a mirror image of the air intake grille shown in FIGS. 1-4.
FIG. 6 is a front elevational view thereof.
FIG. 7 is a cross-sectional view of a portion of the air intake grille shown in FIG. 2, taken along line 7-7; and,
FIG. 8 is a rear elevational view of the air intake grille.
The broken lines shown in the drawings depict portions of the air intake grille that form no part of the claimed design.

1 Claim, 6 Drawing Sheets

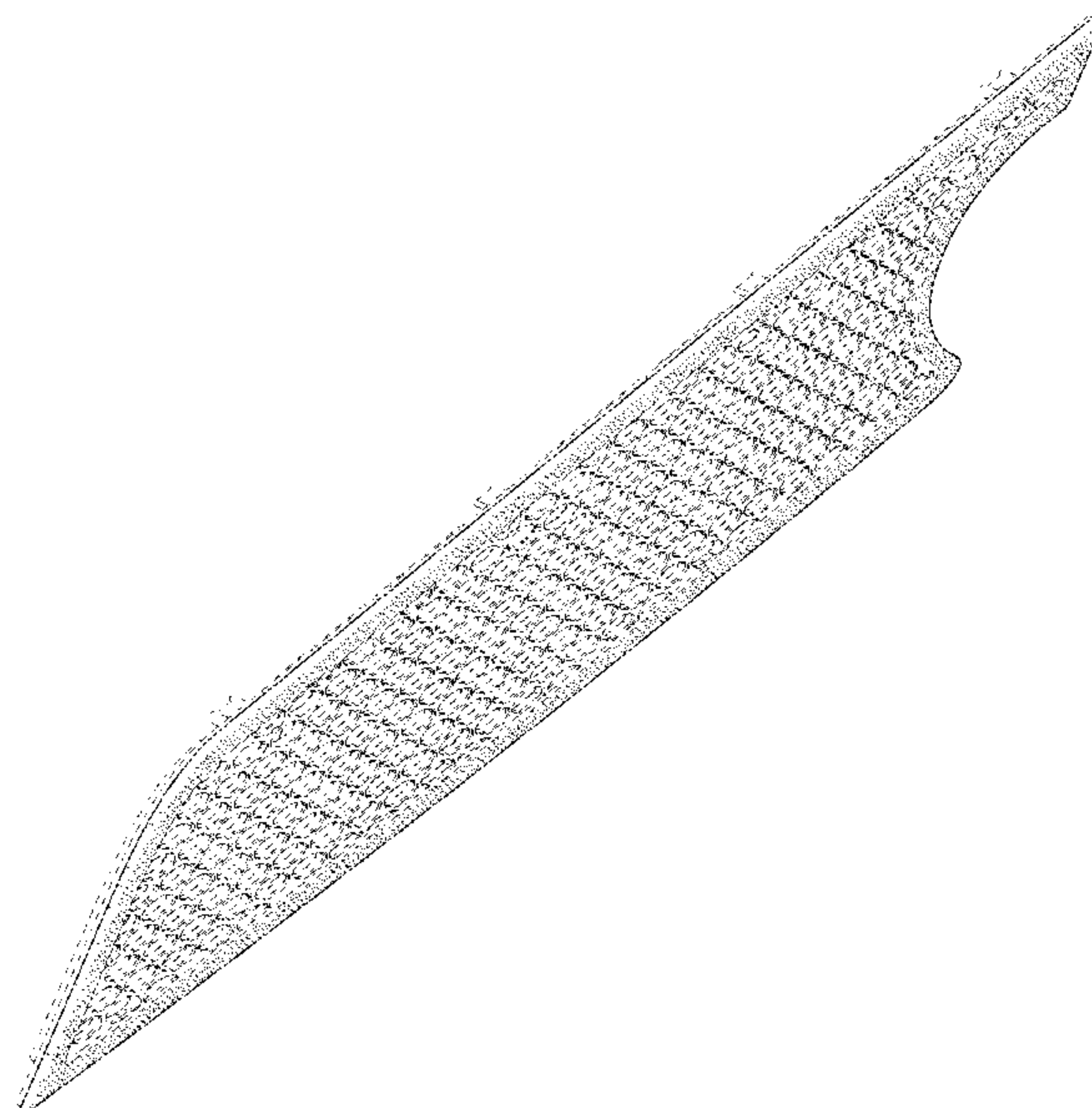

(56)

References Cited

U.S. PATENT DOCUMENTS

D894,070 S	8/2020	Patel et al.	
D916,636 S	4/2021	Grand	
D932,953 S	10/2021	Ratner et al.	
D940,012 S	1/2022	Duncan et al.	
D951,152 S *	5/2022	Piaskowski	D12/163
D962,138 S *	8/2022	Minol	D12/190
D993,118 S	7/2023	Acton et al.	
D993,866 S *	8/2023	Battams	D12/190
D1,001,022 S *	10/2023	Auerbach	D12/163

OTHER PUBLICATIONS

“T800,” Kenworth Truck Company, 2003, 32-page brochure.
 “T800,” Kenworth Truck Company, 2005, 28-page brochure.
 “T800,” Kenworth Truck Company, 2009, 28-page brochure.
 “T800B,” Kenworth Truck Company, 1993, 8-page brochure.
 Peterbilt Motors Company, “The Working Class,” Sep. 1976, 6-page brochure.
 “The World’s Best,” Kenworth Truck Company, 1992, 12-page brochure.
 “W900,” Kenworth Truck Company, 1996, 7-page brochure.
 “W900,” Kenworth Truck Company, 2002, 32-page brochure.
 “W900,” Kenworth Truck Company, 2005, 28-page brochure.
 “W900,” Kenworth Truck Company, 2009, 28-page brochure.
 Kenworth Truck Company, “W900L AeroCab,” 1994, 2-page brochure.
 Kenworth Truck Company, “AeroCab,” 1993, 5-page brochure.
 “AeroCab,” Kenworth Truck Company, as early as 1995, 3-page brochure.
 “C500B,” Kenworth Truck Company, as early as 1990, 4-page brochure.
 Peterbilt Motors Company, “Class Pays, Medium Duty,” Sep. 2000, 12-page brochure.
 “Class Pays, Truck Models,” Peterbilt Motors Company, Mar. 2005, 24-page brochure.
 “Class Pays,” Peterbilt Motors Company, Nov. 1998, 10-page brochure.
 Peterbilt Motors Company, “Class Pays,” Sep. 1997, 10-page brochure.
 “Class Pays, Construction Trucks,” Peterbilt Motors Company, Nov. 2003, 16-page brochure.
 “Kenworth Truck Models,” Kenworth Truck Company, 2010, 16-page brochure.
 Peterbilt Motors Company, “Model 330,” Oct. 1997, 3-page brochure.
 Peterbilt Motors Company, “Model 379,” Apr. 2005, 2-page brochure.

Peterbilt Motors Company, “Model 379,” Mar. 1996, 5-page brochure.
 Peterbilt Motors Company, “Rest with Class,” Apr. 1978, 4-page brochure.
 “T170 Class 5,” Kenworth Truck Company, 2008, 4-page brochure.
 “T270 Class 6 and T370 Class 7,” Kenworth Truck Company, 2008, 6-page brochure.
 “T270 Class 6 and T370 Class 7,” Kenworth Truck Company, 2009, 6-page brochure.
 “T270 Class 6 and T370 Class 7 Hybrid,” Kenworth Truck Company, 2009, 6-page brochure.
 “T680,” Kenworth Truck Company, 2013, 34-page brochure.
 “T680,” Kenworth Truck Company, 2016, 34-page brochure.
 “T880,” Kenworth Truck Company, 2017, 32-page brochure.
 “Model 579,” Peterbilt Motors Company, Oct. 2013, 13-page brochure.
 “Medium Duty,” Peterbilt Motors Company, 2013, 9-page brochure.
 “On-Highway,” Peterbilt Motors Company, 2013, 13-page brochure.
 “Vocational,” Peterbilt Motors Company, 2013, 11-page brochure.
 “T440,” Kenworth Truck Company, 2010, 6-page brochure.
 “T470,” Kenworth Truck Company, 2010, 6-page brochure.
 “T470H,” Kenworth Truck Company, 2009, 2-page brochure.
 “Model 220,” Peterbilt Motors Company, 2019, 2-page brochure.
 “220EV,” Peterbilt Motors Company, 2020, 5-page brochure.
 “Model 337,” Peterbilt Motors Company, 2020, 2-page brochure.
 “Model 389,” Peterbilt Motors Company, 2019, 2-page brochure.
 “Model 348,” Peterbilt Motors Company, 2019, 2-page brochure.
 “Model 520,” Peterbilt Motors Company, 2019, 2-page brochure.
 “Model 567,” Peterbilt Motors Company, 2020, 16-page brochure.
 “567 Heritage,” Peterbilt Motors Company, 2017, 2-page brochure.
 “Model 579,” Peterbilt Motors Company, 2019, 28-page brochure.
 “C500,” Kenworth Truck Company, 2012, 2-page brochure.
 “T680,” Kenworth Truck Company, 2019, 40-page brochure.
 “T800,” Kenworth Truck Company, 2012, 28-page brochure.
 “T440/T470,” Kenworth Truck Company, 2015, 8-page brochure.
 “K270E/K370E,” Kenworth Truck Company, 2020, 4-page brochure.
 “T170/T270/T370,” Kenworth Truck Company, 2019, 16-page brochure.
 “K270/K370,” Kenworth Truck Company, 2014, 12-page brochure.
 “W990,” Kenworth Truck Company, 2018, 32-page brochure.
 “T880,” Kenworth Truck Company, 2019, 36-page brochure.
 “Model 367,” Peterbilt Motors Company, <https://www.peterbilt.com/trucks/vocational/model-367>, retrieved Nov. 20, 2020, 12 pages.
 “Model 365,” Peterbilt Motors Company, <https://www.peterbilt.com/trucks/vocational/model-365>, retrieved Nov. 20, 2020, 11 pages.
 “Model 325,” Peterbilt Motors Company, <https://www.peterbilt.com/trucks/medium-duty/model-325>, retrieved Nov. 20, 2020, 12 pages.

* cited by examiner

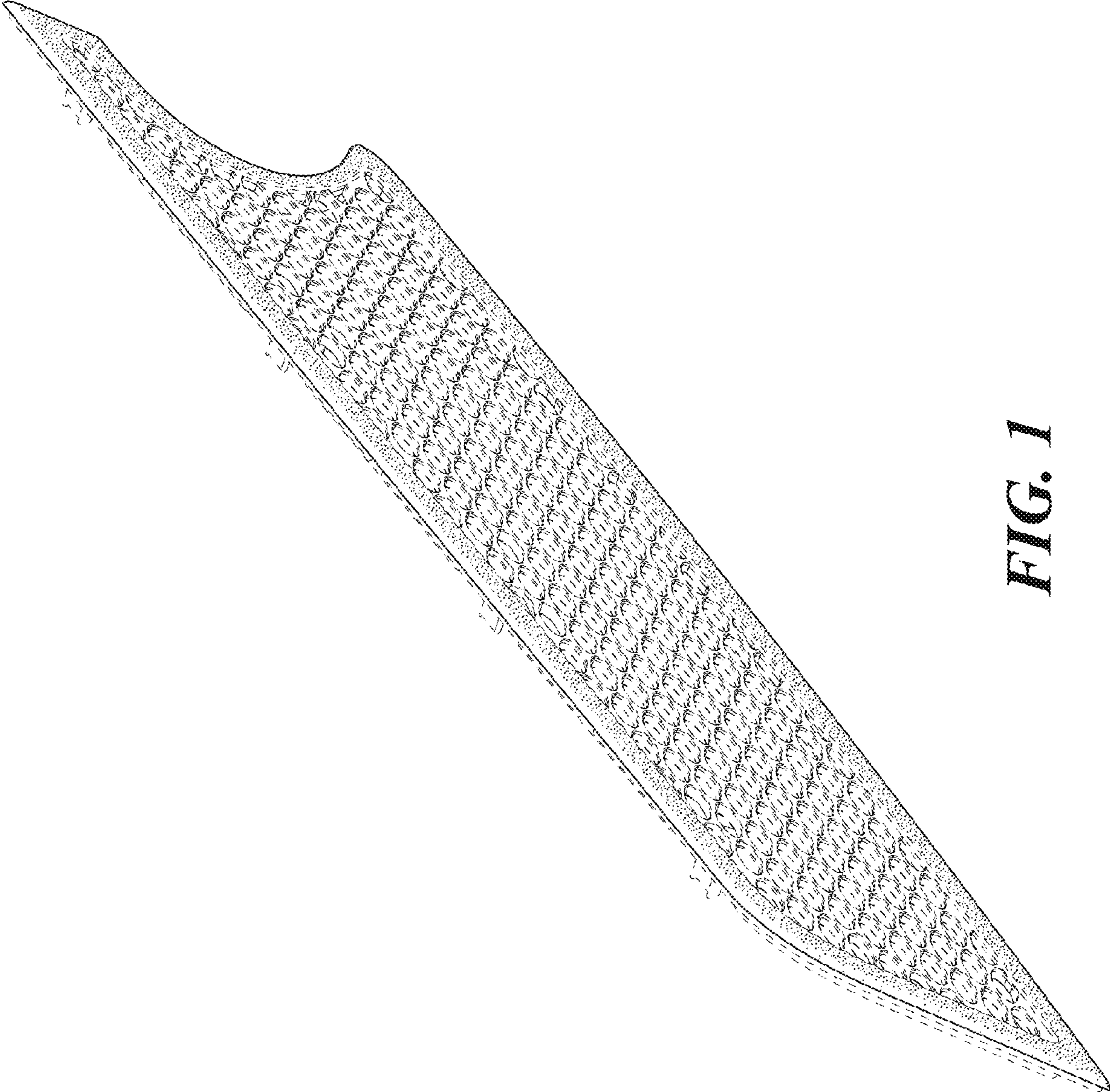

FIG. 1

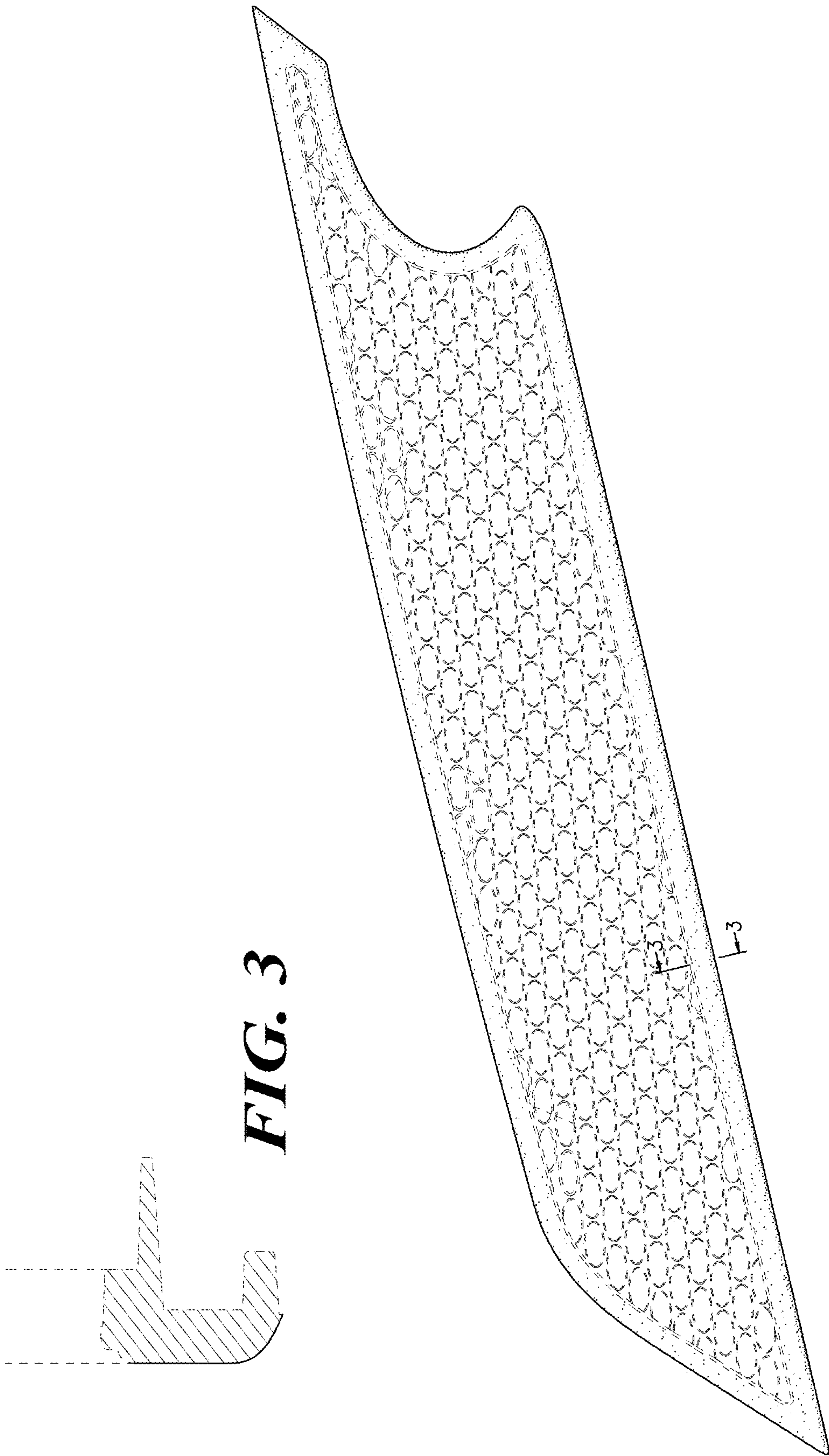

FIG. 3

FIG. 2

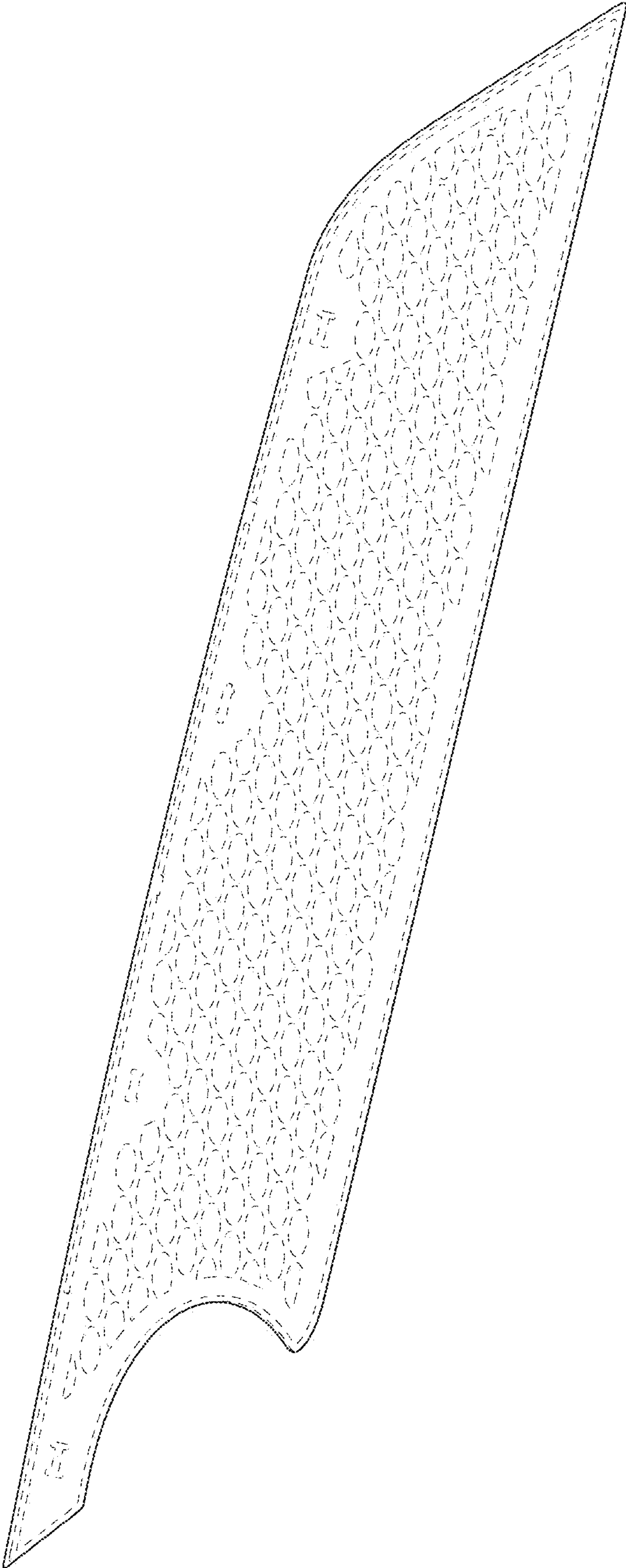

FIG. 4

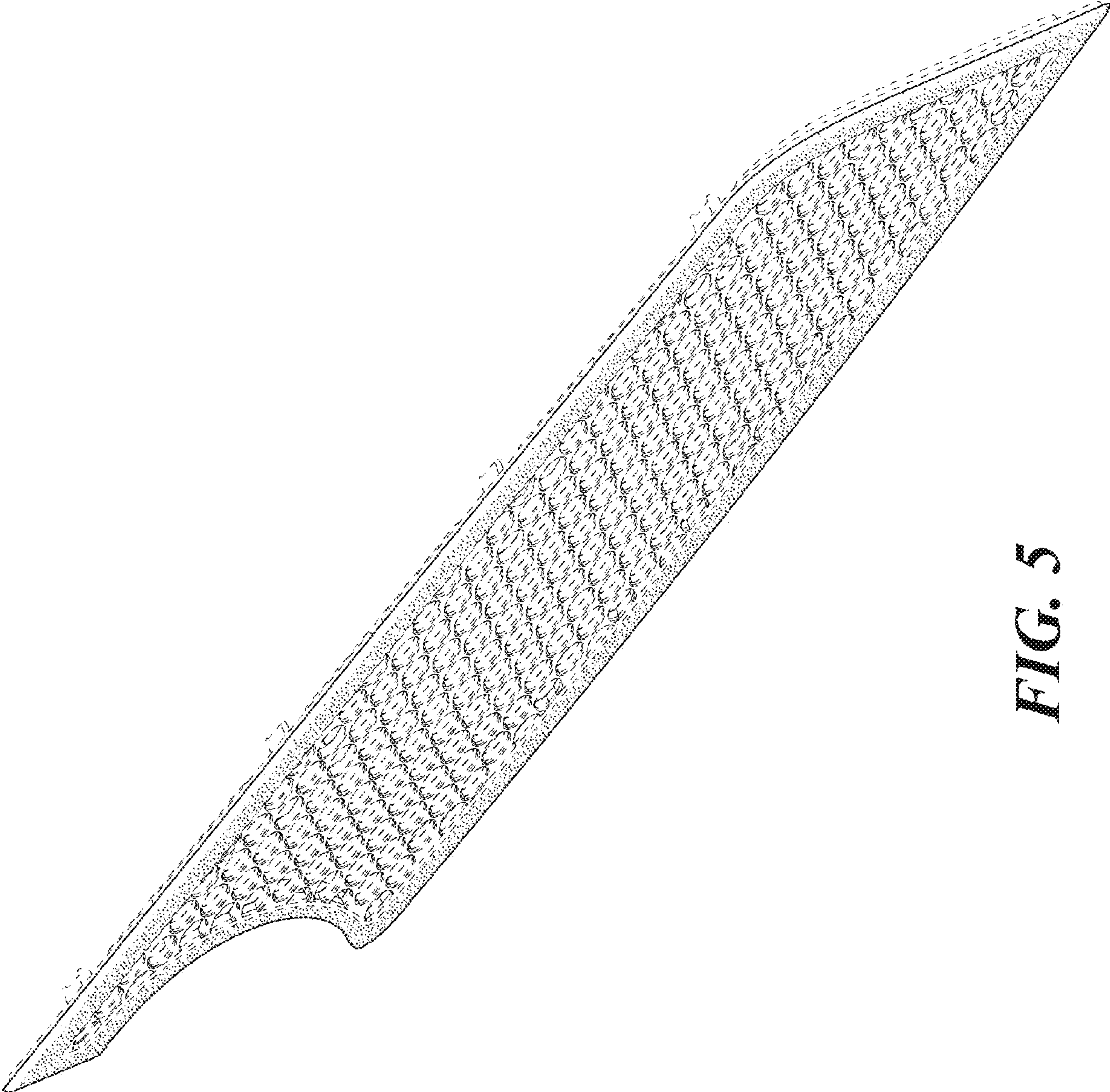

FIG. 5

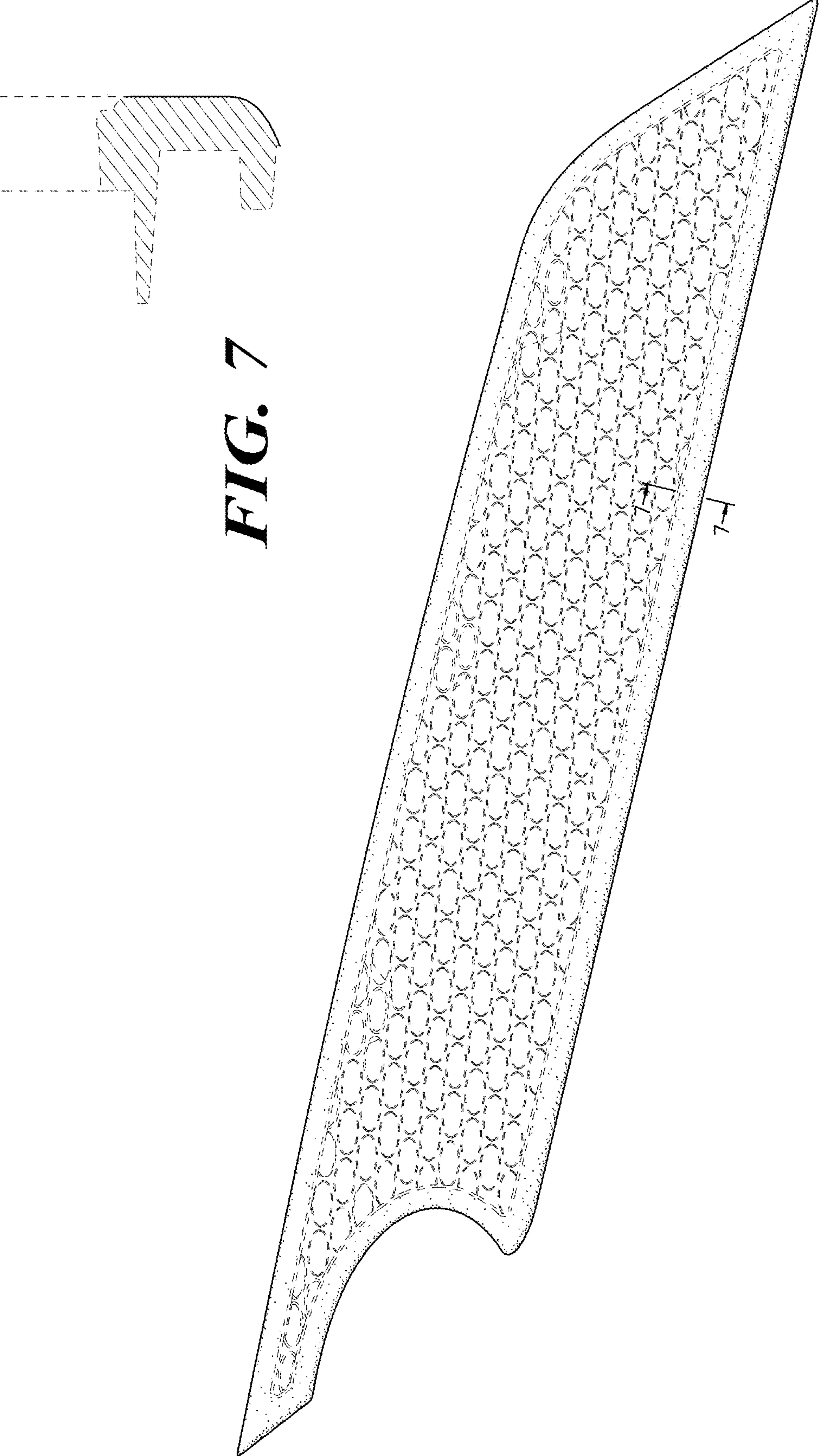

FIG. 7

FIG. 6

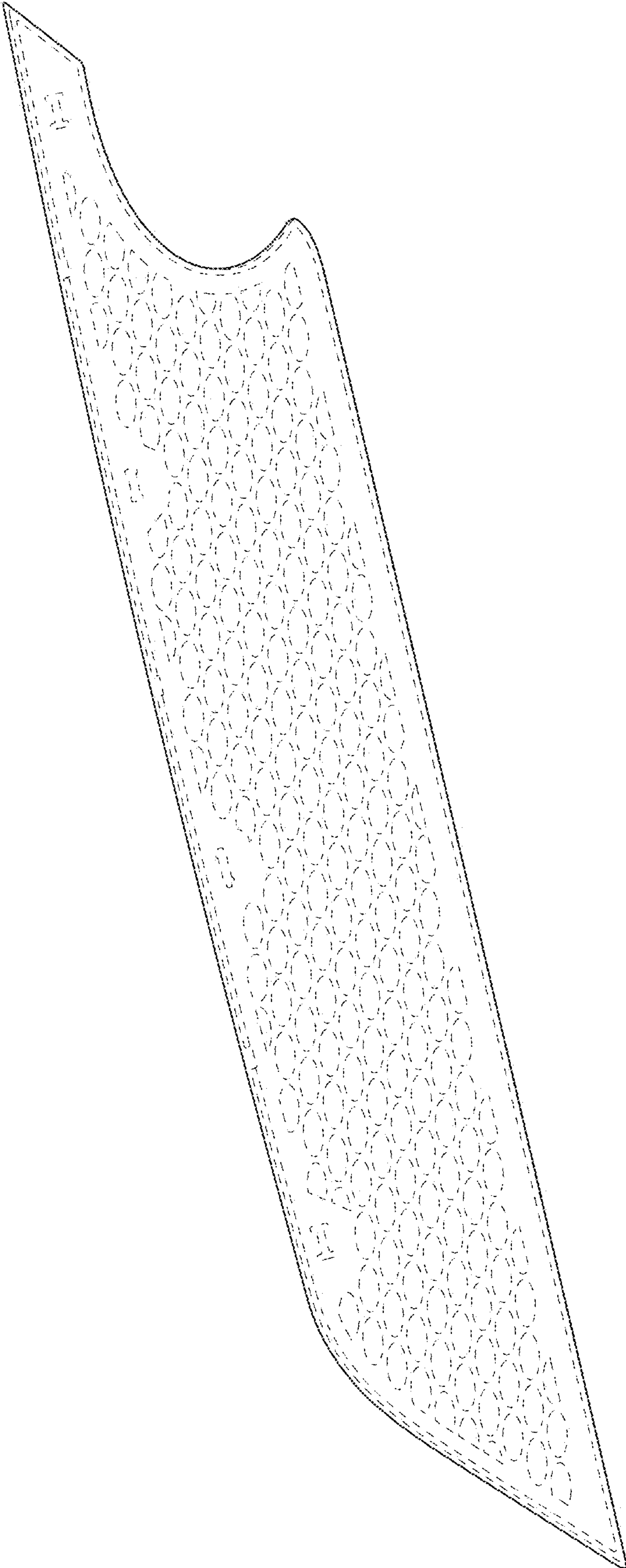

FIG. 8