



US0D1031701S

(12) **United States Design Patent** (10) **Patent No.: US D1,031,701 S**
Roessner et al. (45) **Date of Patent: ** *Jun. 18, 2024**

(54) **RFID INLAY** 5,990,849 A * 11/1999 Salvail H01Q 1/36
343/729
(71) Applicant: **AdvanIDe Holdings Pte. Ltd.**, 7,374,105 B2 5/2008 Zhu et al.
Singapore (SG) 7,618,204 B2 11/2009 Blanchard, Jr. et al.
D706,246 S 6/2014 Forster
(72) Inventors: **Holger Roessner**, Singapore (SG); **Joe** D716,774 S 11/2014 Forster et al.
Lo, Singapore (SG); **Alejandro** D820,241 S 6/2018 Howard
Placitelli, Montevideo (UY) 10,108,894 B2 10/2018 Pic
10,547,112 B2 1/2020 Kang et al.
D896,208 S * 9/2020 Howard D14/230
(73) Assignee: **AdvanIDe Holdings Pte. Ltd.**,
Singapore (SG) (Continued)

FOREIGN PATENT DOCUMENTS

(*) Notice: This patent is subject to a terminal disclaimer.
(**) Term: **15 Years**

CN 306695876 7/2021
CN 307169800 * 3/2022
(Continued)

(21) Appl. No.: **29/911,880**
(22) Filed: **Sep. 11, 2023**

OTHER PUBLICATIONS

Avery Dennison, "AD Circus Slix Slix 2," available at rfid.averydennison.com, date published 2021, site visited Jul. 6, 2023, available at URL: <https://rfid.averydennison.com/en/home/product-finder/circus.html> (Year: 2021).
(Continued)

Related U.S. Application Data

(63) Continuation of application No. 29/819,298, filed on Dec. 14, 2021, now Pat. No. Des. 1,002,596.
(51) **LOC (14) Cl.** **14-03**
(52) **U.S. Cl.**
USPC **D14/230**
(58) **Field of Classification Search**
USPC D14/230, 231-240, 243, 299, 358, 217,
D14/138; D13/182; D23/264, 266, 367
CPC H01Q 1/243; H01Q 1/36; H01Q 1/50;
H01Q 7/00; H01Q 9/045; H01Q 9/285;
H01W 1/38; H04B 1/034; H04B 1/045;
H04B 2001/0408; H05K 11/00
See application file for complete search history.

Primary Examiner — Daniel J Domino
Assistant Examiner — Samina Vieth
(74) *Attorney, Agent, or Firm* — Maier & Maier, PLLC

(57) **CLAIM**

The ornamental design for an RFID inlay, as shown and described.

DESCRIPTION

FIG. 1 is a top view of an RFID inlay, showing our design; FIG. 2 is a bottom view thereof; and, FIG. 3 is an isometric view thereof. The broken line showing in the Figures forms no part of the claimed design.

(56) **References Cited**
U.S. PATENT DOCUMENTS

4,559,539 A 12/1985 Markowitz et al.
5,457,469 A 10/1995 Diamond et al.

1 Claim, 3 Drawing Sheets

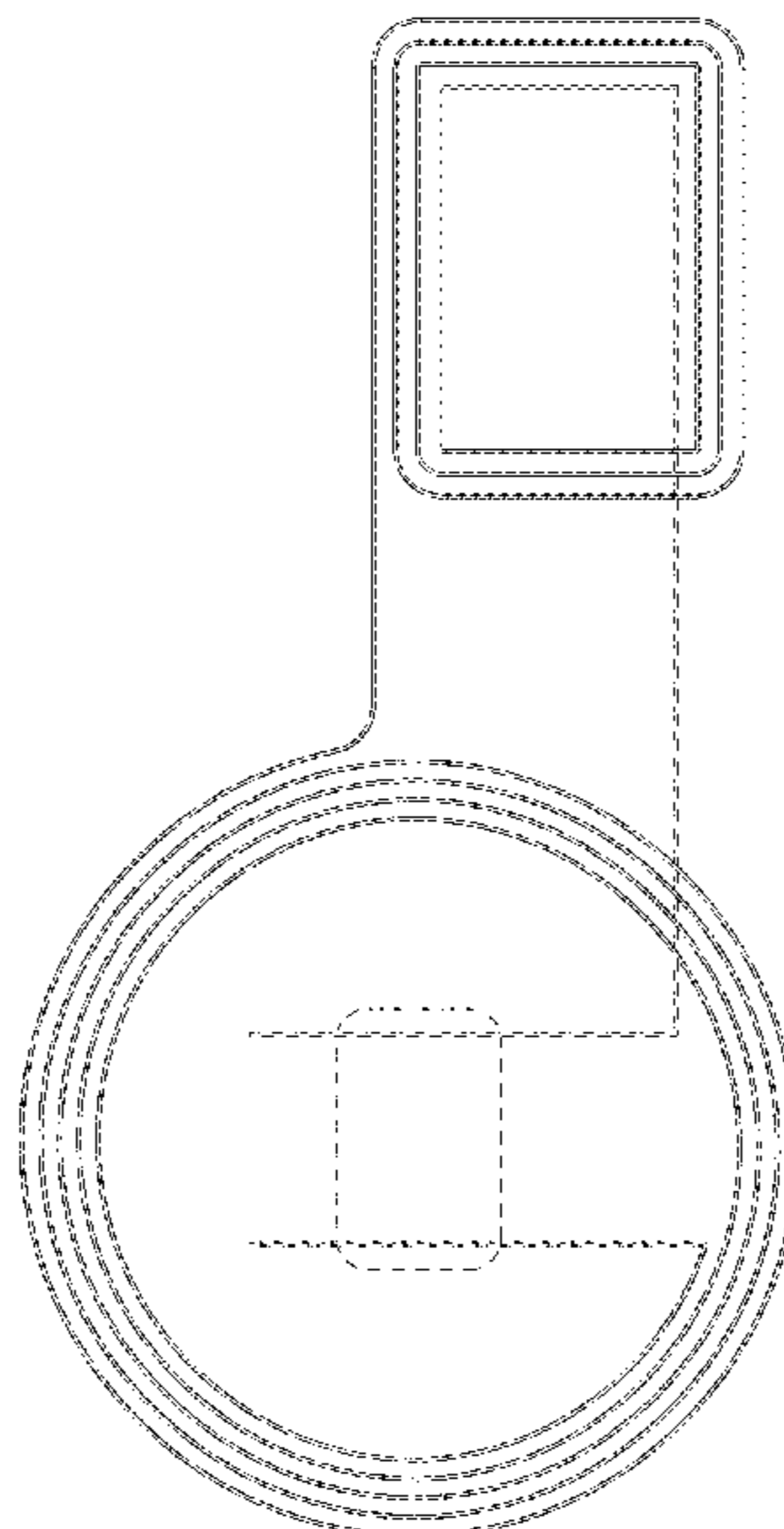

(56)

References Cited

U.S. PATENT DOCUMENTS

D926,166 S * 7/2021 Alina D14/230
 D954,691 S * 6/2022 Atojoko D14/230
 D959,393 S * 8/2022 Sugiura D13/182
 D964,327 S 9/2022 Quiambao
 11,551,050 B2 1/2023 Placitelli et al.
 D980,177 S 3/2023 Sugiura et al.
 D1,002,596 S * 10/2023 Roessner D14/230
 D1,003,281 S * 10/2023 Roessner D14/230
 2003/0184495 A1 * 10/2003 Tomon H01Q 1/2225
 343/866
 2014/0028528 A1 1/2014 Tanabe
 2014/0292610 A1 * 10/2014 Iwahashi H01Q 1/38
 343/867
 2017/0054213 A1 * 2/2017 Singh H04B 5/0037
 2018/0197063 A1 * 7/2018 Kapoor G06K 19/077
 2018/0205143 A1 7/2018 Sy et al.
 2018/0248255 A1 * 8/2018 Noh H01F 27/2871
 2022/0230037 A1 * 7/2022 Roessner G07F 7/0833
 2023/0045326 A1 * 2/2023 Placitelli G06K 19/0772
 2023/0169295 A1 6/2023 Leibbrand et al.

FOREIGN PATENT DOCUMENTS

CN 307326666 5/2022
 CN 307412123 * 6/2022

CN 307986884 * 4/2023
 CN 307996889 * 4/2023
 CN 308048850 * 5/2023

OTHER PUBLICATIONS

Adafruit, "NTAG 203 (13.56MHz RFID/NFC) Clear Keychain Fob", available at [adafruit.com](https://www.adafruit.com/product/5459#technical-details), date published Oct. 17, 2011, site visited Jul. 6, 2023, available at URL: <https://www.adafruit.com/product/5459#technical-details> (Year: 2011).
 Christian Merz, "Impedance Matching for Near Field Communication Applications", available at www.we-online.com, date published Dec. 10, 2020, site visited Jul. 6, 2023, available at URL: <https://www.we-online.com/components/media/o207264v410%20ANP084a%20EN.pdf> (Year: 2020).
 TDK, Wireless Power Transfer, "Overview of WR524830-16F3-NF-G," available at uk.farnell.com, date published Jan. 28, 2017, site visited Jul. 6, 2023, available at URL: <https://uk.farnell.com/tdk/wr524830-16f3-nf-g/charging-coil-19-5uh-nfc-antenna/dp/2790534> (Year: 2017).
 NXP Semiconductors, "NTAG203 NFC Forum type 2 tag compliant IC with 144 bytes user memory", Rev. 3.0, URL: <https://www.nxp.com>, Oct. 17, 2011, (Year: 2011).

* cited by examiner

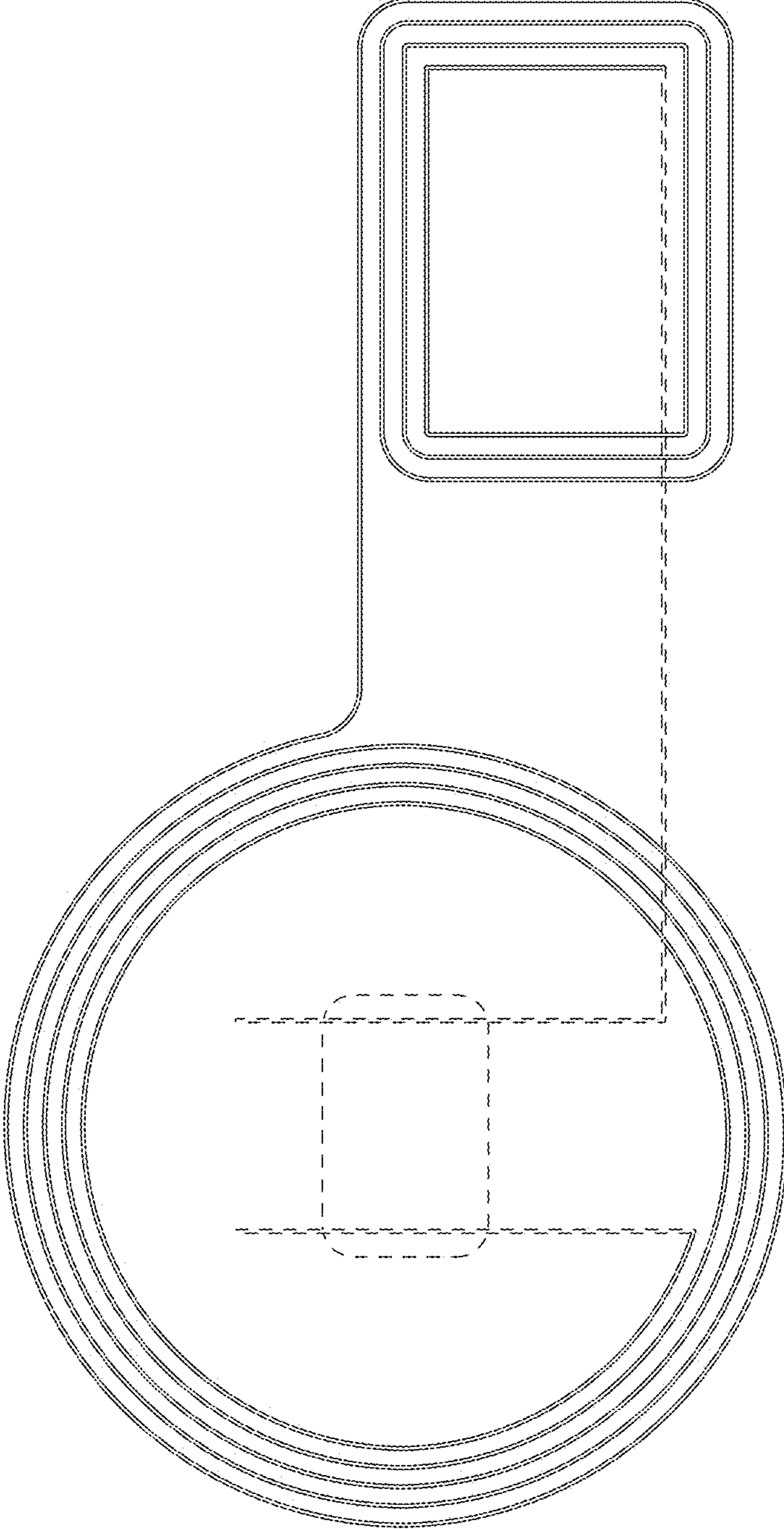

Fig. 1

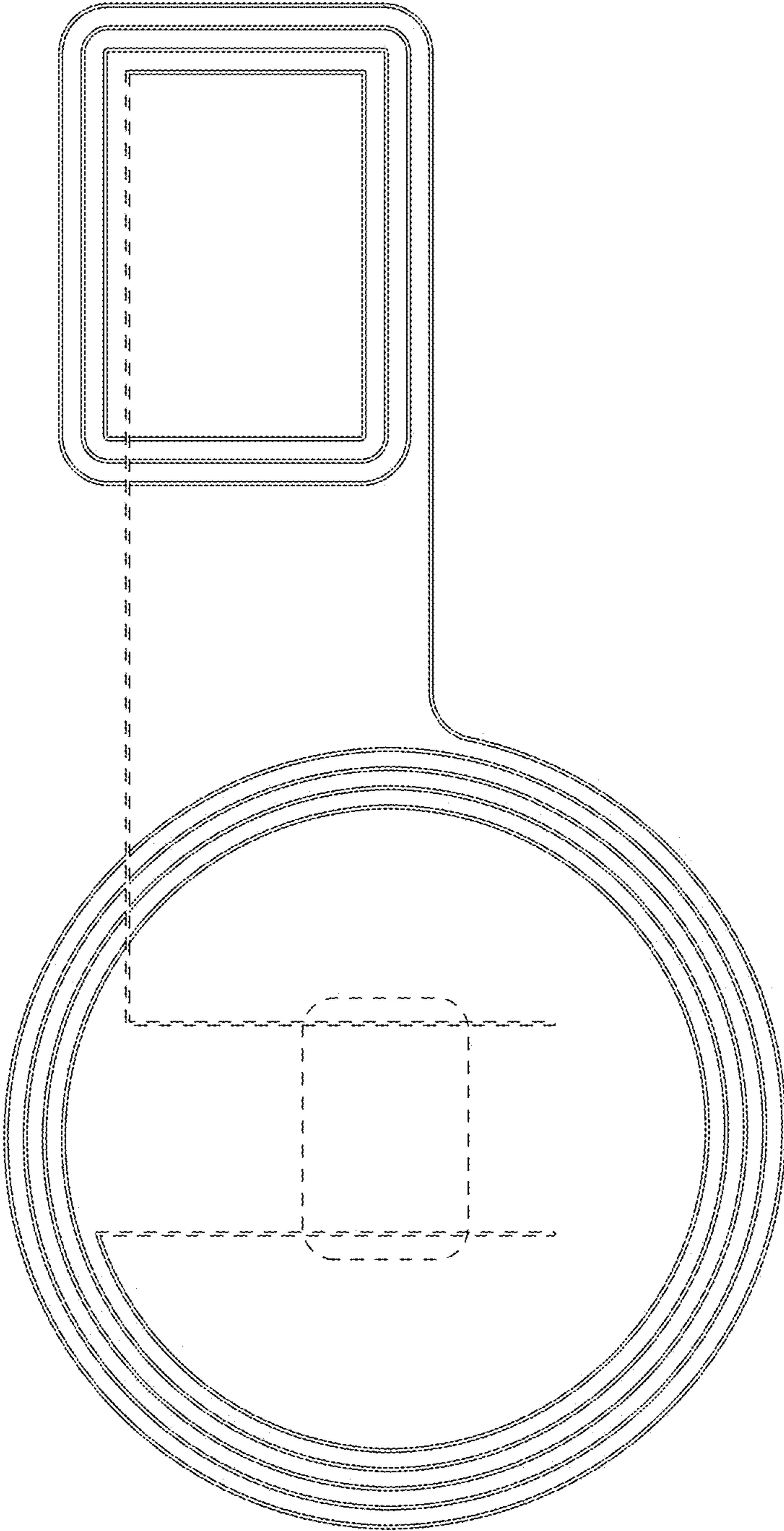

Fig. 2

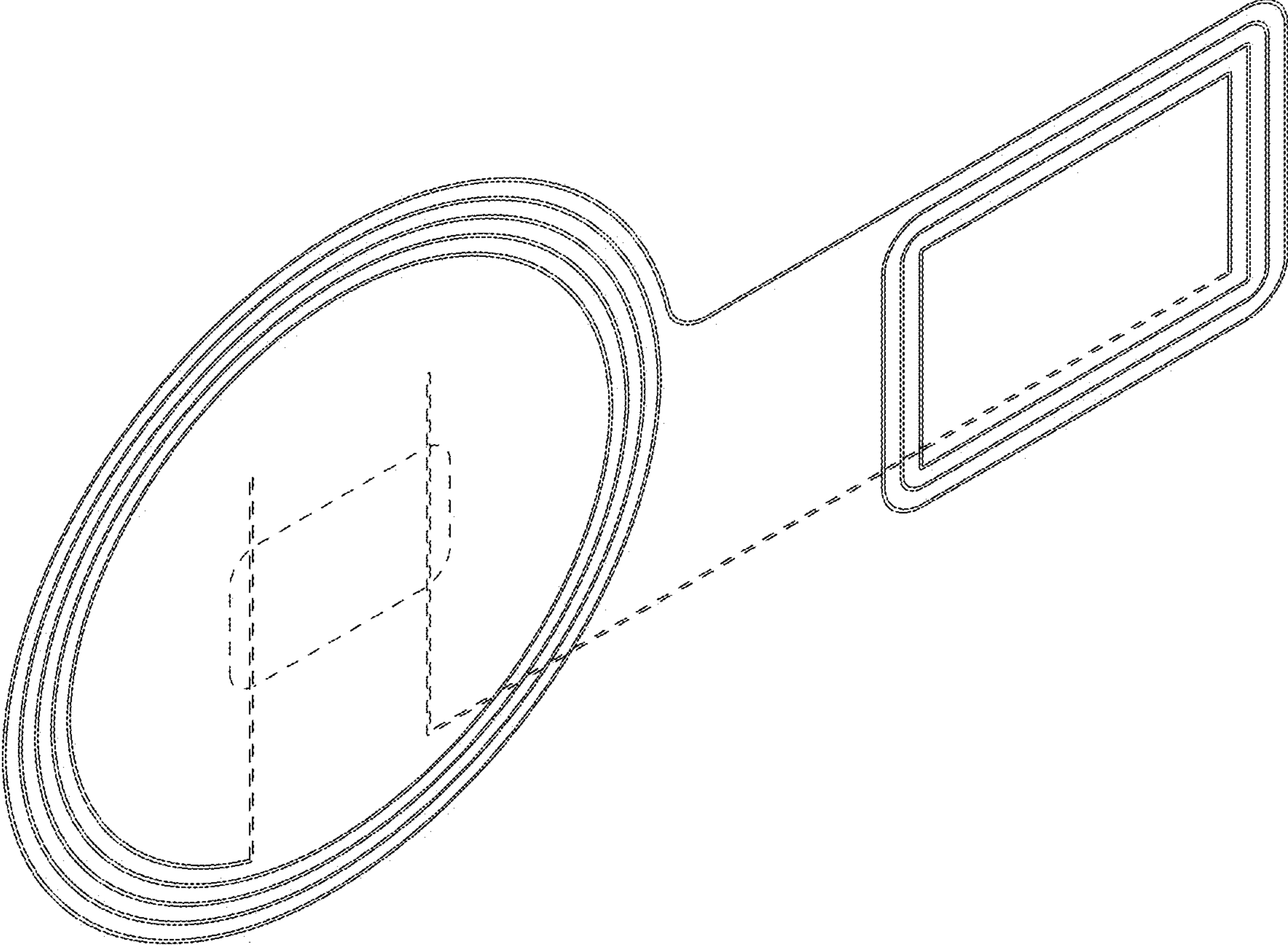

Fig. 3