



US0D1031135S

(12) **United States Design Patent**  
**Conway et al.**

(10) **Patent No.:** **US D1,031,135 S**

(45) **Date of Patent:** **\*\* Jun. 11, 2024**

(54) **HEADLAMP**

(71) Applicant: **PACCAR Inc**, Bellevue, WA (US)

(72) Inventors: **Scott M. Conway**, Flower Mound, TX (US); **Jon Forrest Acton**, Fort Worth, TX (US); **Louis Daniel Heilaneh**, Lewisville, TX (US)

(73) Assignee: **PACCAR Inc**, Bellevue, WA (US)

(\*\*) Term: **15 Years**

(21) Appl. No.: **29/753,537**

(22) Filed: **Sep. 30, 2020**

(51) **LOC (14) Cl.** ..... **26-06**

(52) **U.S. Cl.**  
USPC ..... **D26/28**

(58) **Field of Classification Search**  
USPC ..... D26/28-36, 113, 118, 120, 122, 139;  
D12/400, 196, 190

(Continued)

(56) **References Cited**

**U.S. PATENT DOCUMENTS**

D421,817 S 3/2000 Tucker et al.  
D524,958 S \* 7/2006 Sakae ..... D26/28  
(Continued)

**FOREIGN PATENT DOCUMENTS**

CN 303999319 \* 1/2017  
JP D1606315 \* 6/2019

**OTHER PUBLICATIONS**

Peterbilt unleashes most 'game-changing' truck to date, available in fleetowner.com, announced Year 2021 [online], [site visited May 11, 2023], Internet URL: <https://www.fleetowner.com/equipment/media-gallery/21154108/peterbilt-unleashes-most-gamechanging-truck-to-date> (Year: 2021).\*

(Continued)

*Primary Examiner* — Sharon S Oum

*Assistant Examiner* — Raylen E Worthington

(74) *Attorney, Agent, or Firm* — Seed IP Law Group LLP

(57) **CLAIM**

The ornamental design for a headlamp, as shown and described.

**DESCRIPTION**

FIG. 1 is a top isometric view of a headlamp, showing a first embodiment of our new design.

FIG. 2 is a bottom isometric view thereof.

FIG. 3 is a front elevational view thereof.

FIG. 4 is a right side elevational view thereof.

FIG. 5 is a top plan view thereof.

FIG. 6 is a top isometric view of a headlamp, showing a second embodiment of our new design, which is a mirror image of the headlamp shown in FIGS. 1-5.

FIG. 7 is a bottom isometric view thereof.

FIG. 8 is a front elevational view thereof.

FIG. 9 is a left side elevational view thereof.

FIG. 10 is a top plan view thereof.

FIG. 11 is a top isometric view of a headlamp, showing a third embodiment of our new design.

FIG. 12 is a bottom isometric view thereof.

FIG. 13 is a front elevational view thereof.

FIG. 14 is a right side elevational view thereof.

FIG. 15 is a top plan view thereof.

FIG. 16 is a top isometric view of a headlamp, showing a fourth embodiment of our new design, which is a mirror image of the headlamp shown in FIGS. 11-15.

FIG. 17 is a bottom isometric view thereof.

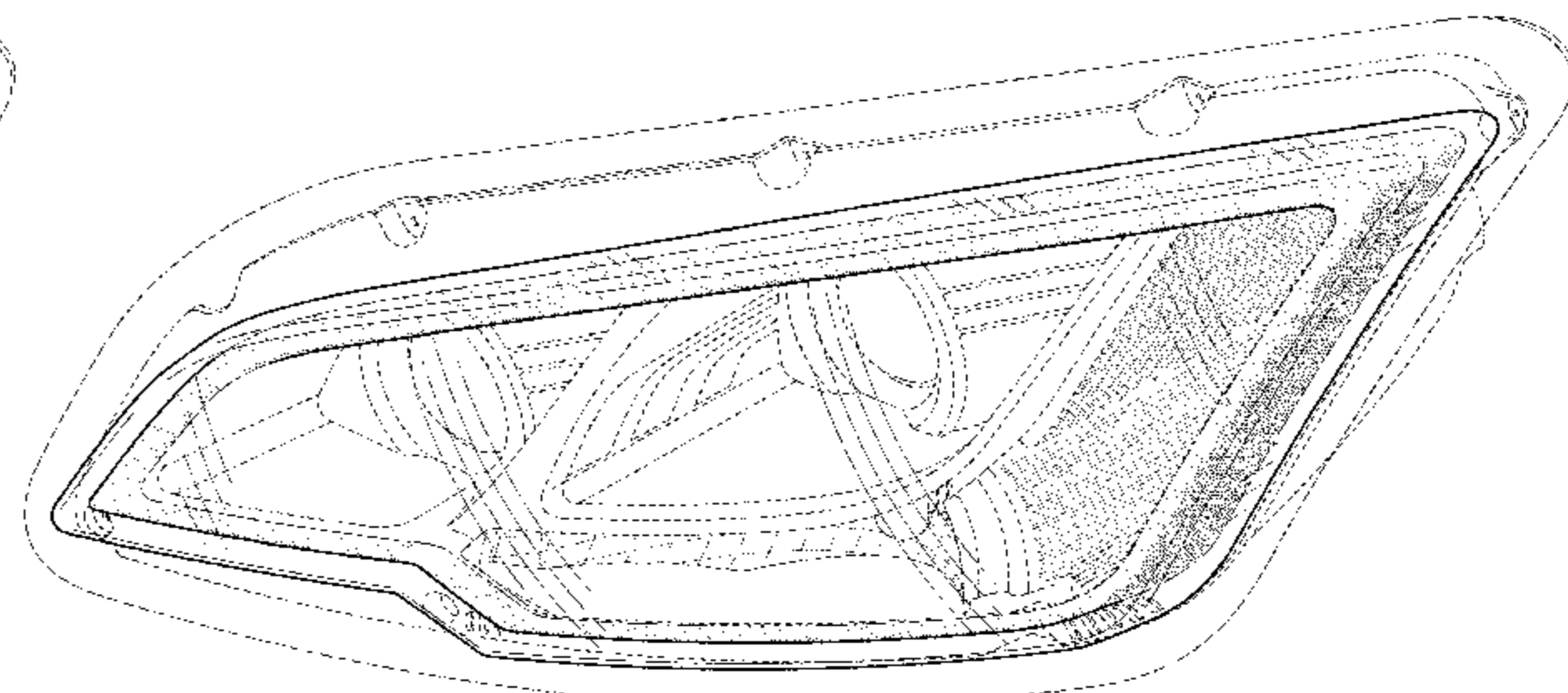
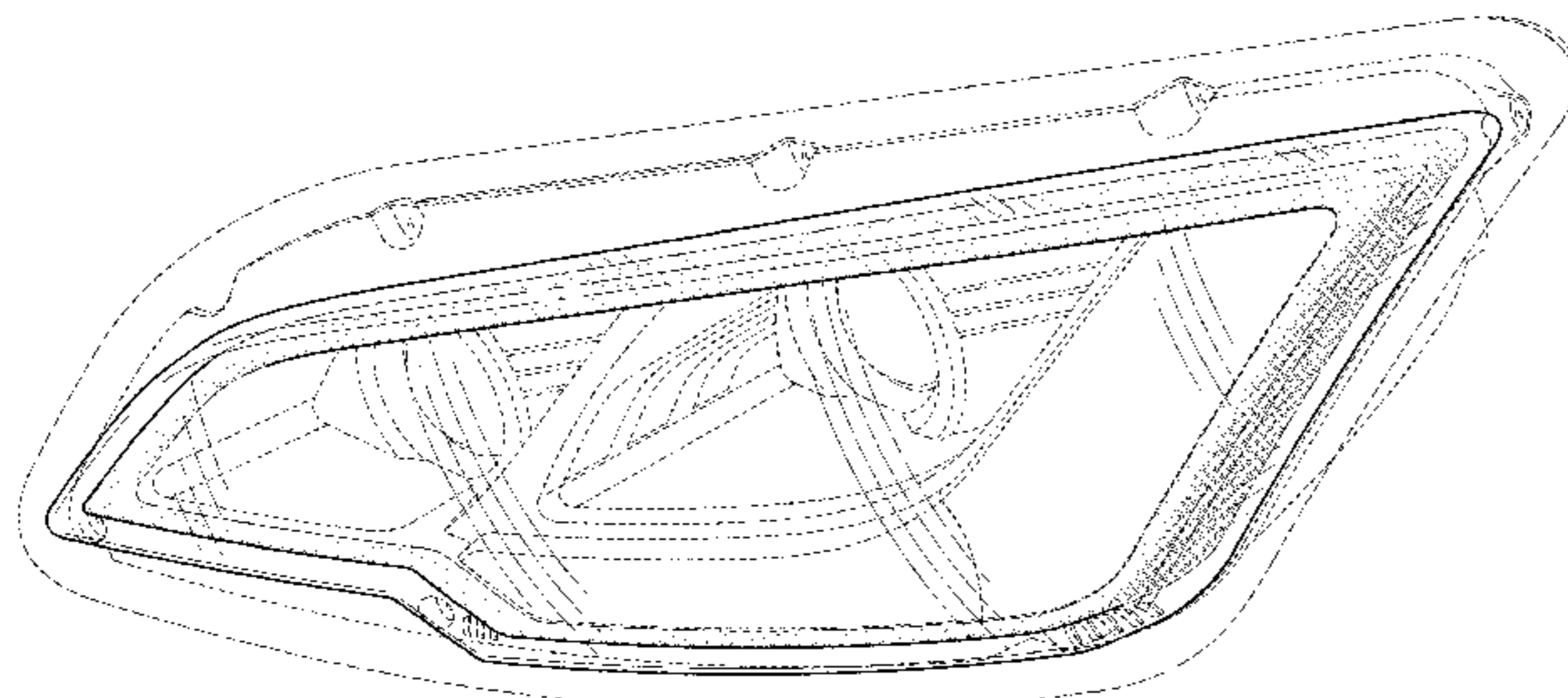
FIG. 18 is a front elevational view thereof.

FIG. 19 is a left side elevational view thereof; and,

FIG. 20 is a top plan view thereof.

Stippling in the drawings represent the three-dimensional contours of the design, and is not intended to indicate surface decoration. The dash-dash broken lines shown in the drawings depict portions of the headlamp that form no part of the claimed design. The long dash-short dash lines represent boundaries and form no part of the claimed design.

**1 Claim, 20 Drawing Sheets**



(58) **Field of Classification Search**

CPC ..... B60Q 1/2615; B60Q 1/26; B60Q 1/2619;  
 B60Q 1/2607; B60Q 1/44; F21S 43/00;  
 F21S 43/10; F21S 43/13

See application file for complete search history.

D852,996 S \* 7/2019 Suzuki ..... D26/28  
 D869,032 S 12/2019 Conway et al.  
 D883,527 S \* 5/2020 Lin ..... D26/28

OTHER PUBLICATIONS

CarLights360: For Kia Forte Headlight 2010 11 12 2013 Pair Driver and Passenger Side Black Housing w/Bulbs Replaces KI2502141 + KI2503141, available in Amazon.com, date first available Mar. 10, 2019 [online], [site visited May 11, 2023], Available from the internet URL: <https://www.amazon.com/dp/B07PJF8CN4/> (Year: 2019).\*

(56) **References Cited**

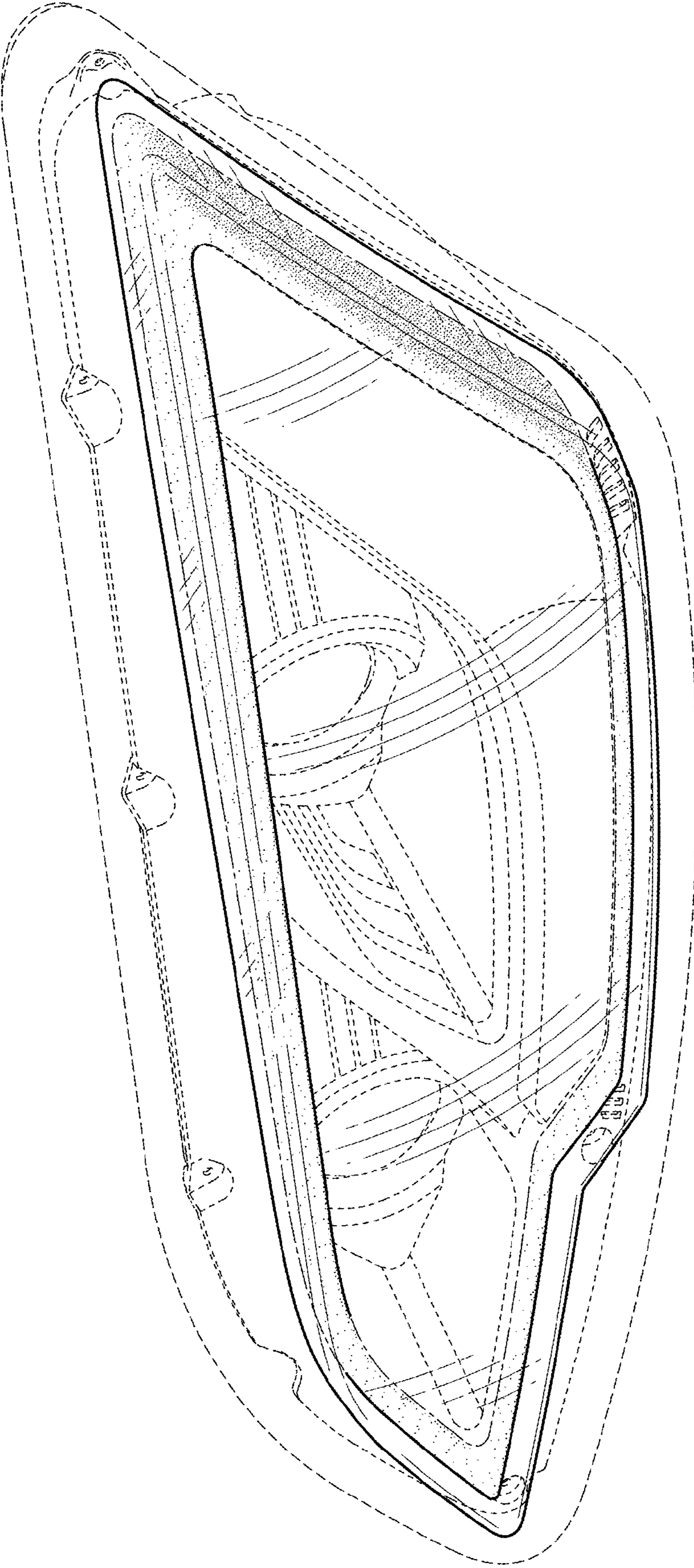
U.S. PATENT DOCUMENTS

D525,731 S 7/2006 Hovind et al.  
 D526,429 S 8/2006 Hovind et al.  
 D542,442 S \* 5/2007 Matsunami ..... D26/28  
 D550,871 S 9/2007 Conway et al.  
 D564,130 S 3/2008 Conway et al.  
 D565,758 S 4/2008 Conway et al.  
 D583,968 S 12/2008 Simons et al.  
 D615,221 S 5/2010 Simons et al.  
 D630,780 S \* 1/2011 Roller ..... D26/28  
 D639,502 S 6/2011 Heilaneh et al.  
 D647,225 S 10/2011 Conway et al.  
 D676,166 S \* 2/2013 Lai ..... D26/28  
 D695,433 S \* 12/2013 Mascadri ..... D26/28  
 D696,453 S 12/2013 Conway et al.  
 D696,454 S 12/2013 Conway et al.  
 D697,256 S 1/2014 Conway et al.  
 D697,257 S 1/2014 Conway et al.  
 D697,258 S 1/2014 Conway et al.  
 D697,259 S 1/2014 Conway et al.  
 D709,644 S 7/2014 Hovind et al.  
 D709,645 S 7/2014 Hovind et al.  
 D770,649 S \* 11/2016 Lim ..... D26/28  
 D774,222 S \* 12/2016 Lim ..... D26/28  
 D811,650 S \* 2/2018 Bucher ..... D26/139  
 D812,267 S \* 3/2018 Bucher ..... D26/28  
 D812,791 S \* 3/2018 Wu ..... D26/28  
 D820,510 S 6/2018 Conway et al.  
 D821,026 S 6/2018 Conway et al.  
 D841,877 S 2/2019 Conway et al.  
 D848,039 S 5/2019 Conway et al.

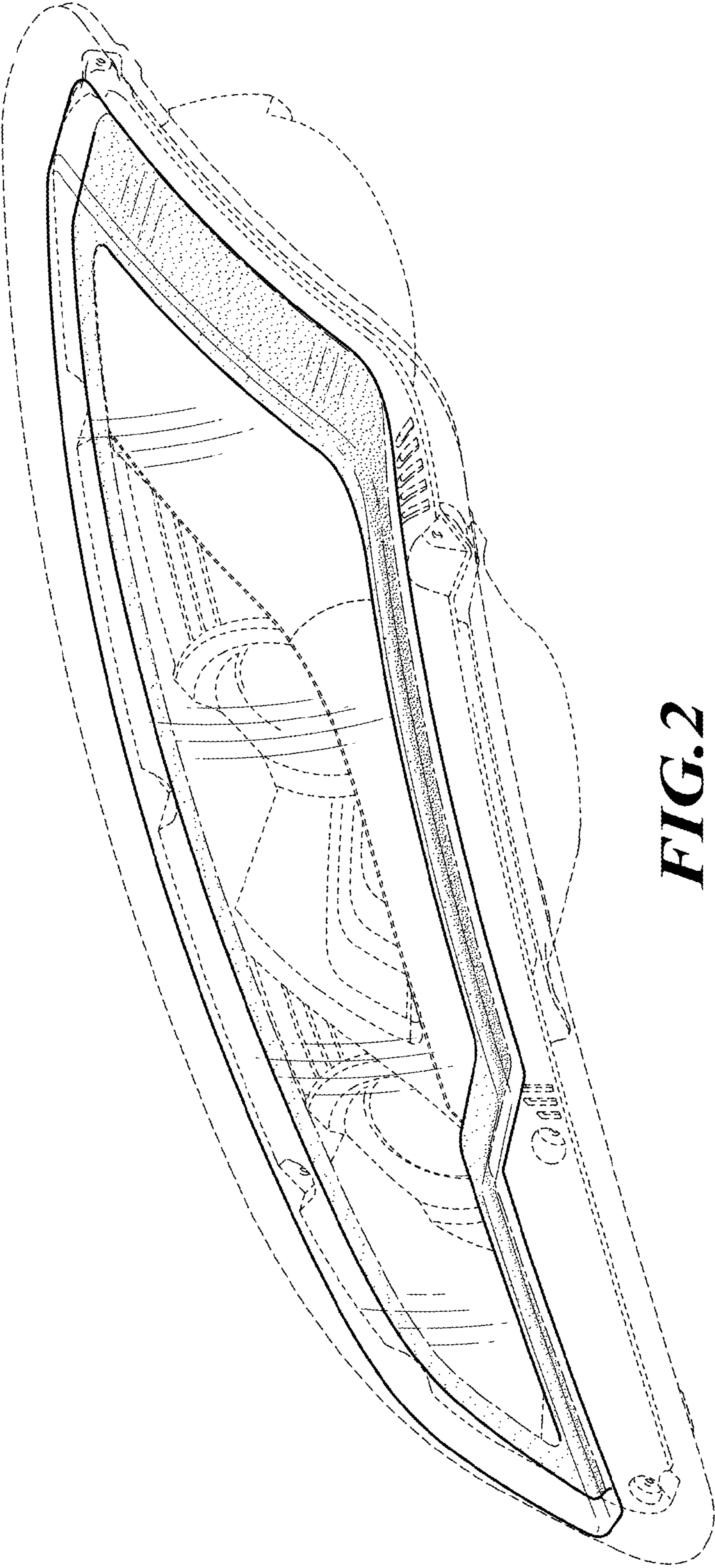
"Model 220," Peterbilt Motors Company, 2019, 2-page brochure.  
 "220EV," Peterbilt Motors Company, 2020, 5-page brochure.  
 "Model 337," Peterbilt Motors Company, 2020, 2-page brochure.  
 "Model 389," Peterbilt Motors Company, 2019, 2-page brochure.  
 "Model 348," Peterbilt Motors Company, 2019, 2-page brochure.  
 "Model 520," Peterbilt Motors Company, 2019, 2-page brochure.  
 "Model 567," Peterbilt Motors Company, 2020, 16-page brochure.  
 "567 Heritage," Peterbilt Motors Company, 2017, 2-page brochure.  
 "Model 579," Peterbilt Motors Company, 2019, 28-page brochure.  
 "C500," Kenworth Truck Company, 2012, 2-page brochure.  
 "T680," Kenworth Truck Company, 2019, 40-page brochure.  
 "T800," Kenworth Truck Company, 2012, 28-page brochure.  
 "T440/T470," Kenworth Truck Company, 2015, 8-page brochure.  
 "K270E/K370E," Kenworth Truck Company, 2020, 4-page brochure.  
 "T170/T270/T370," Kenworth Truck Company, 2019, 16-page brochure.  
 "K270/K370," Kenworth Truck Company, 2014, 12-page brochure.  
 "W990," Kenworth Truck Company, 2018, 32-page brochure.  
 "T880," Kenworth Truck Company, 2019, 36-page brochure.  
 "Model 367," Peterbilt Motors Company, <https://www.peterbilt.com/trucks/vocational/model-367>, retrieved Nov. 20, 2020, 12 pages.  
 "Model 365," Peterbilt Motors Company, <https://www.peterbilt.com/trucks/vocational/model-365>, retrieved Nov. 20, 2020, 11 pages.  
 "Model 325," Peterbilt Motors Company, <https://www.peterbilt.com/trucks/medium-duty/model-325>, retrieved Nov. 20, 2020, 12 pages.

\* cited by examiner

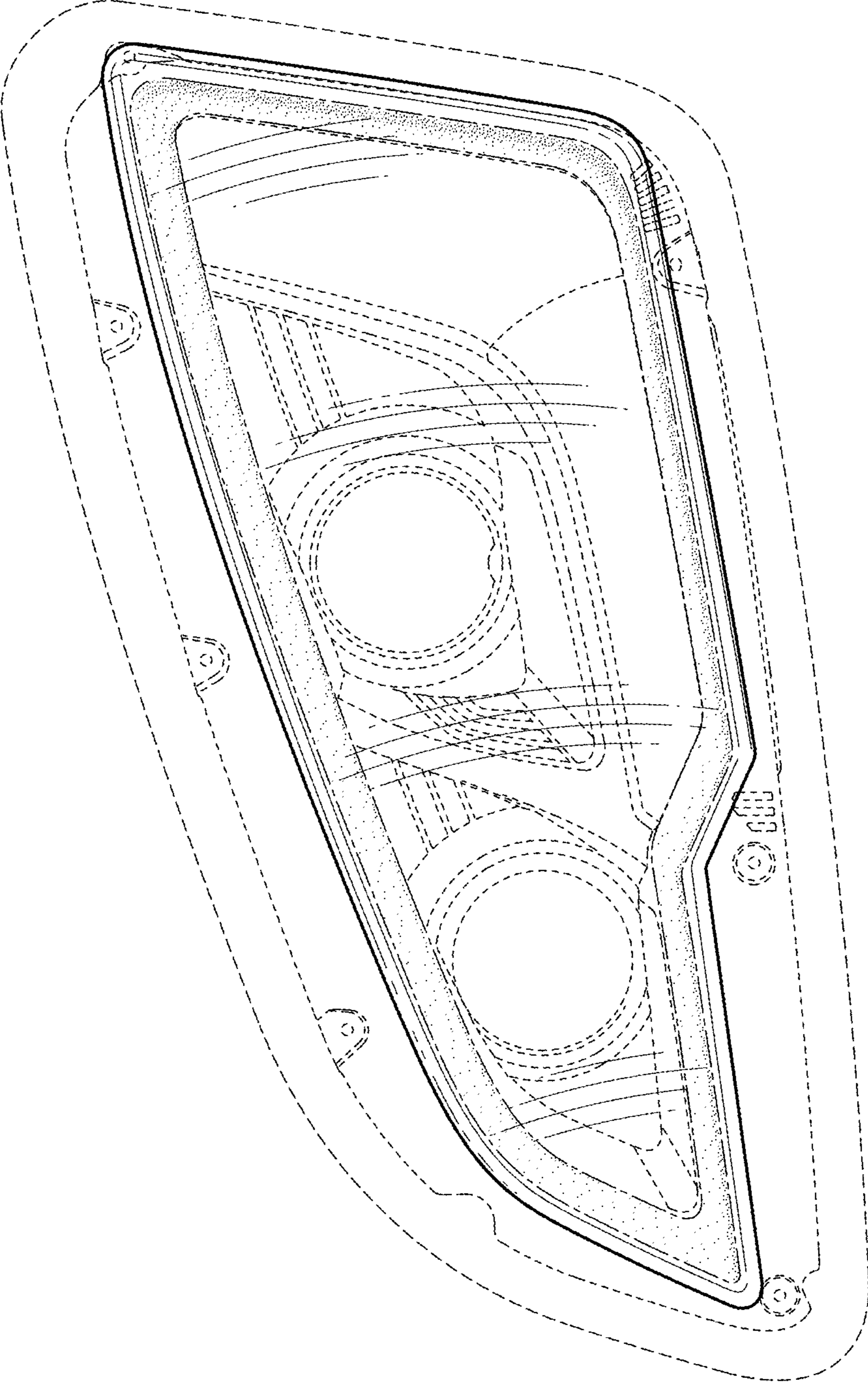




**FIG. 1**

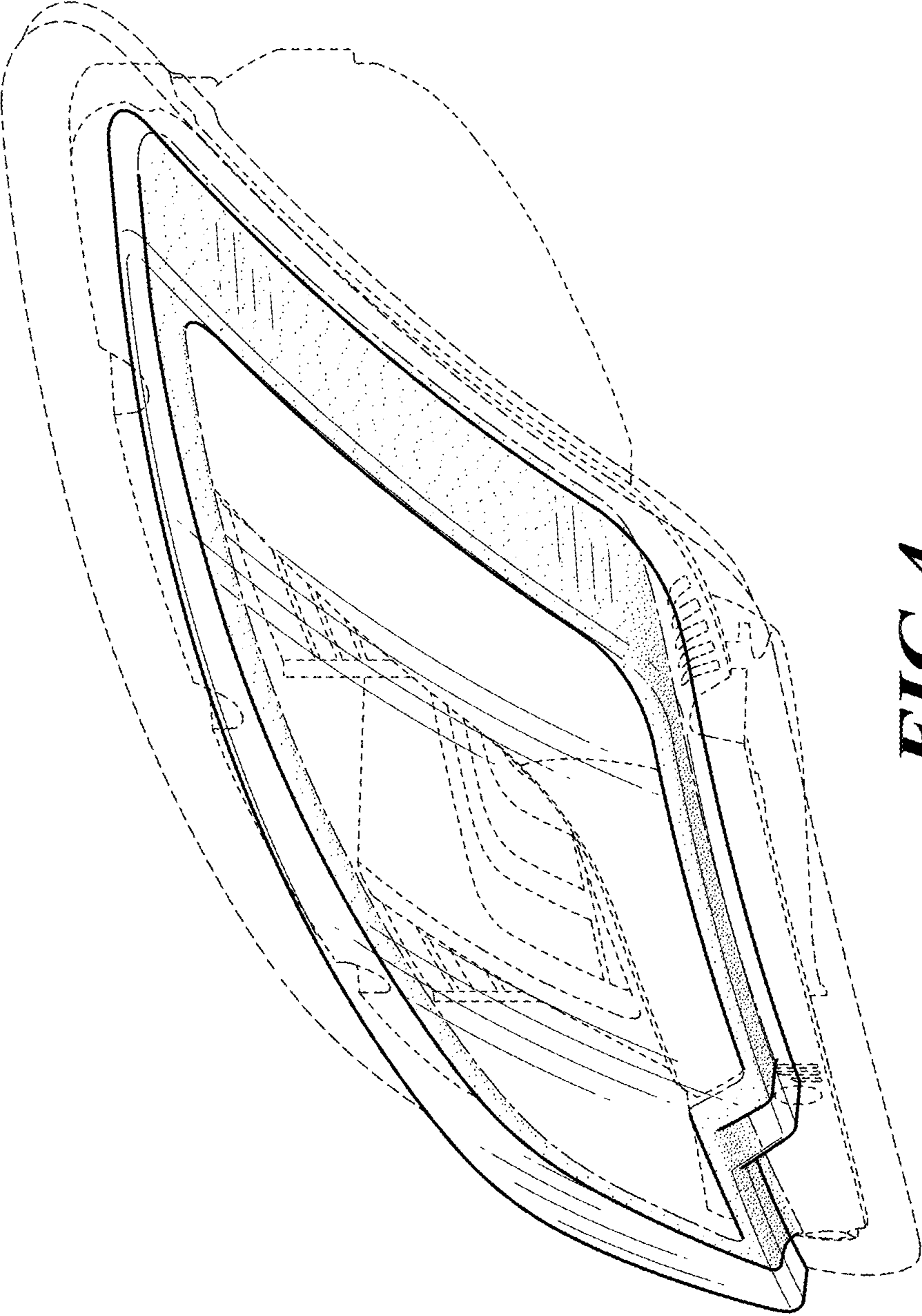


**FIG. 2**

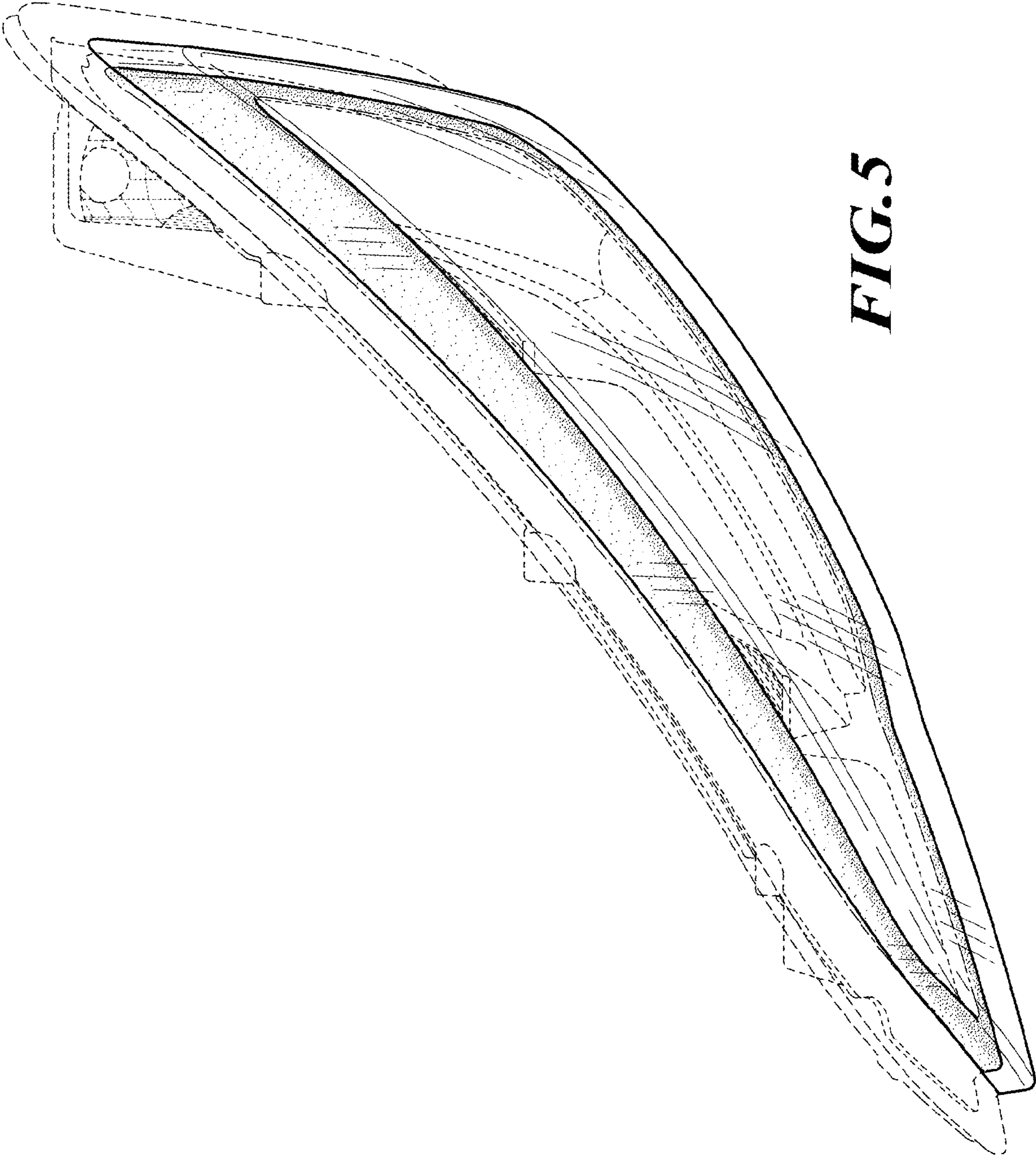


**FIG. 3**

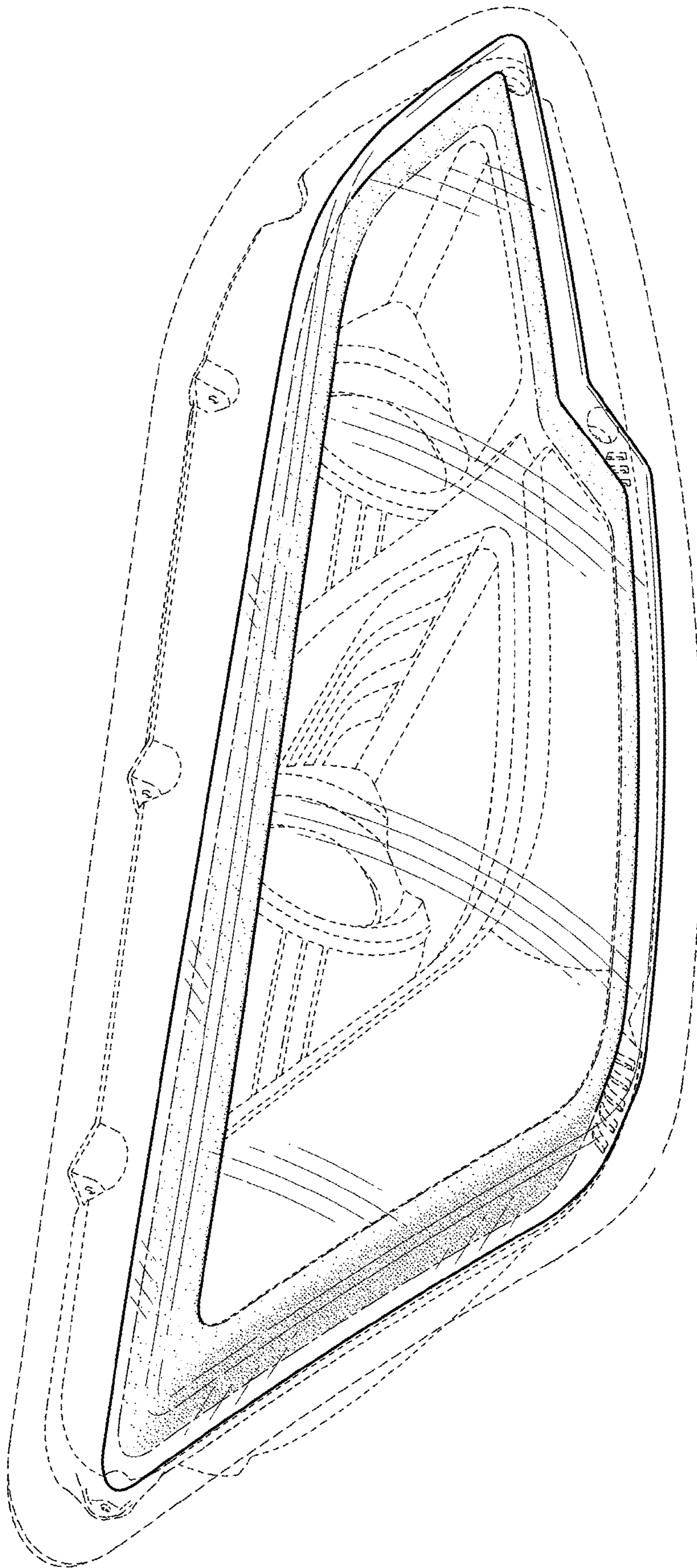




**FIG. 4**

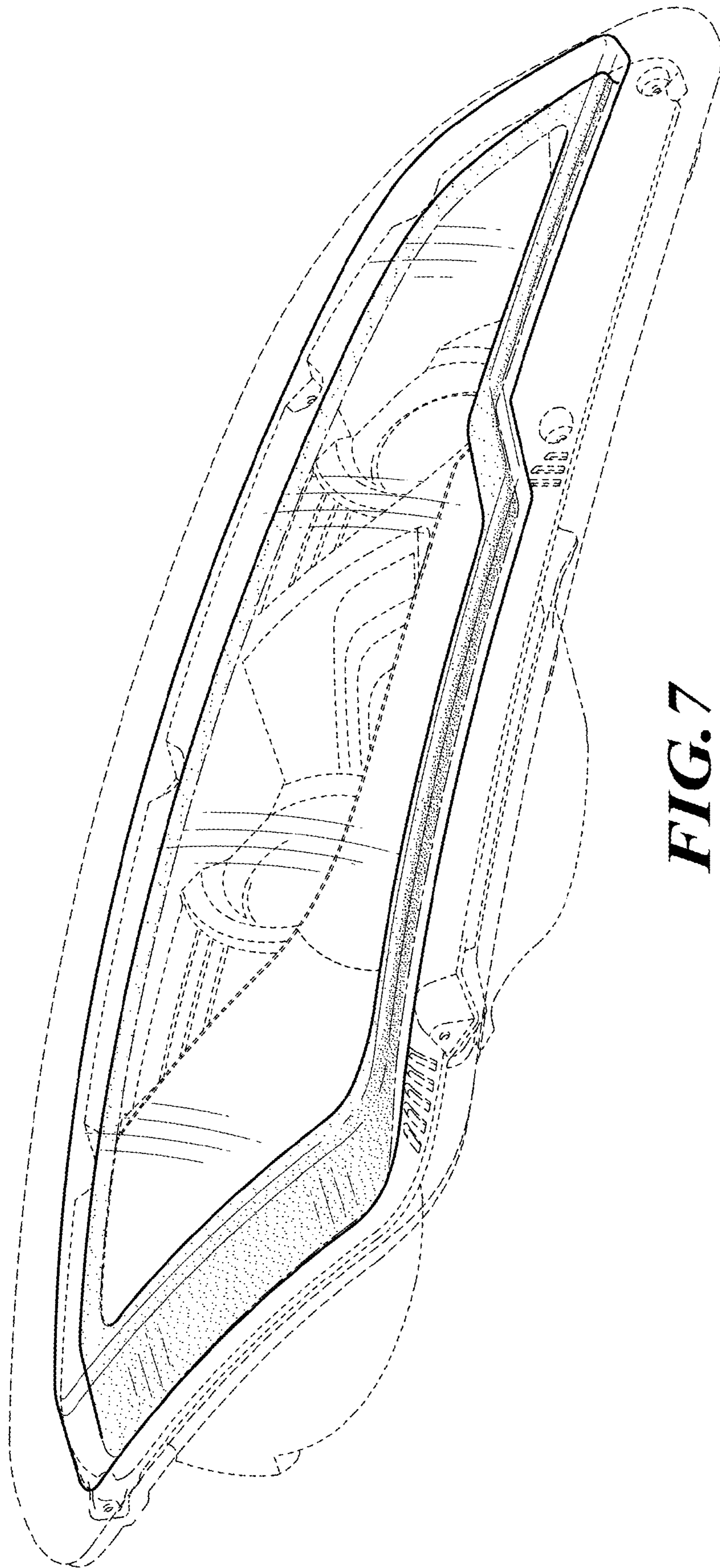


**FIG. 5**

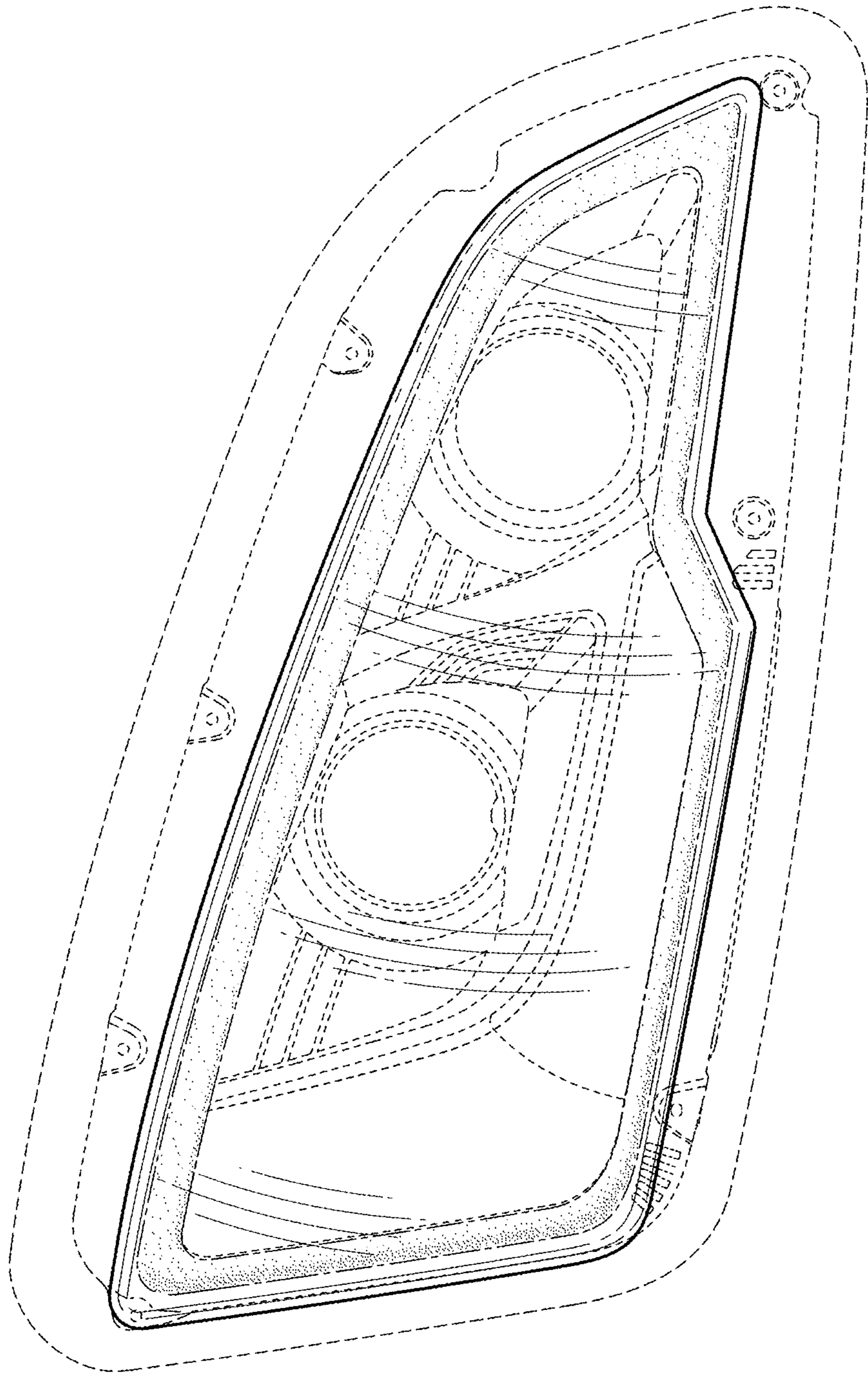


**FIG. 6**

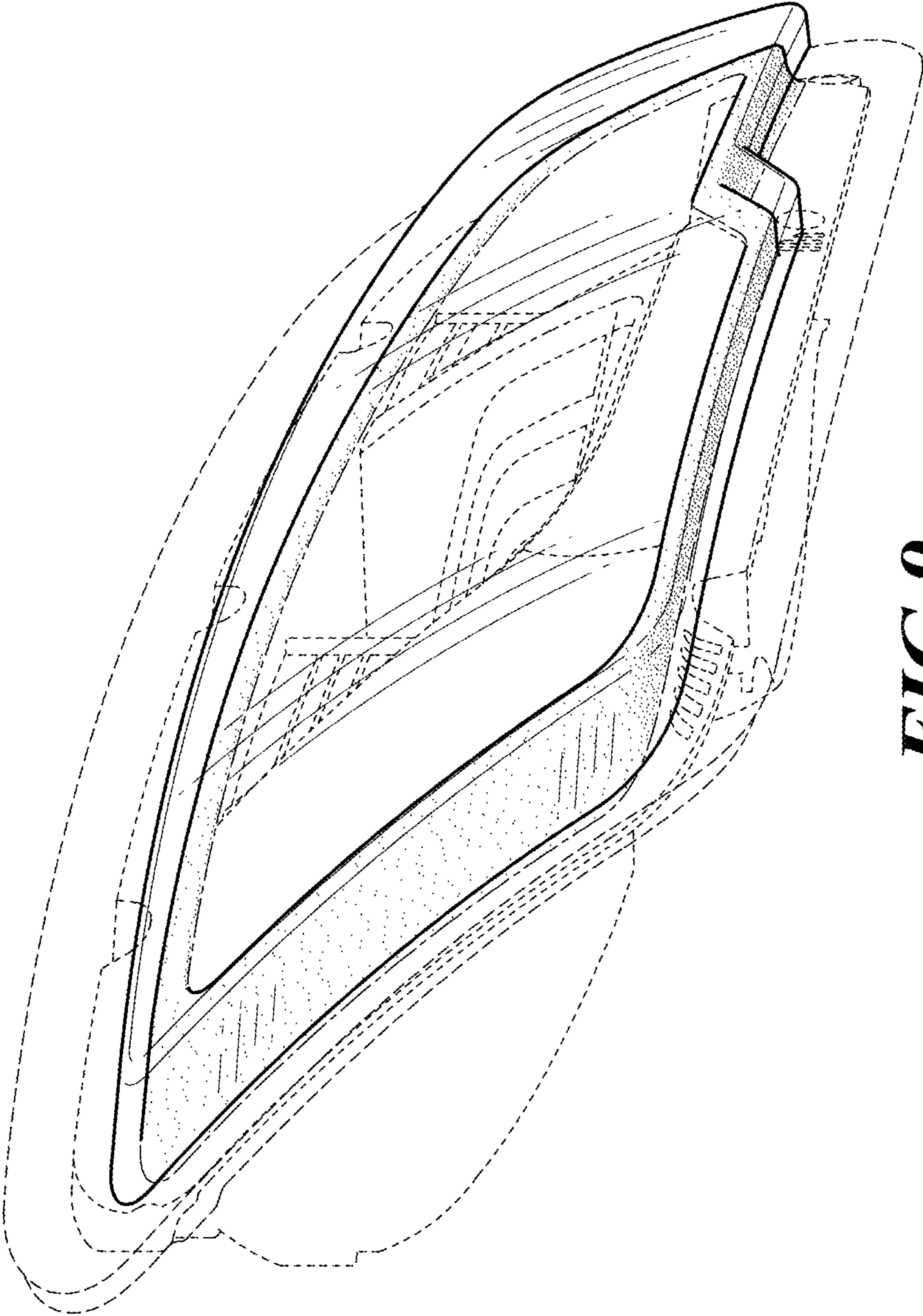




**FIG. 7**

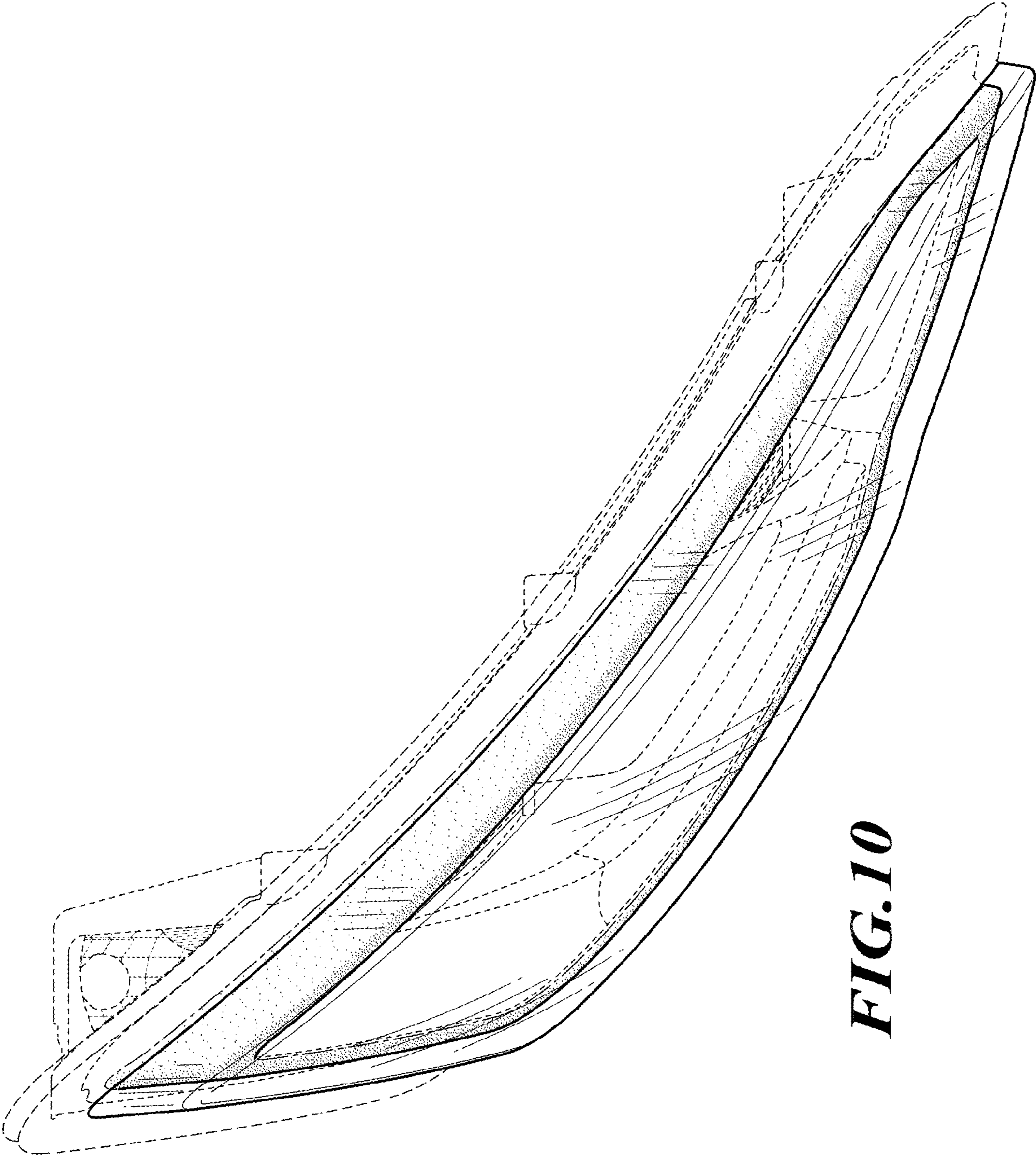


**FIG. 8**

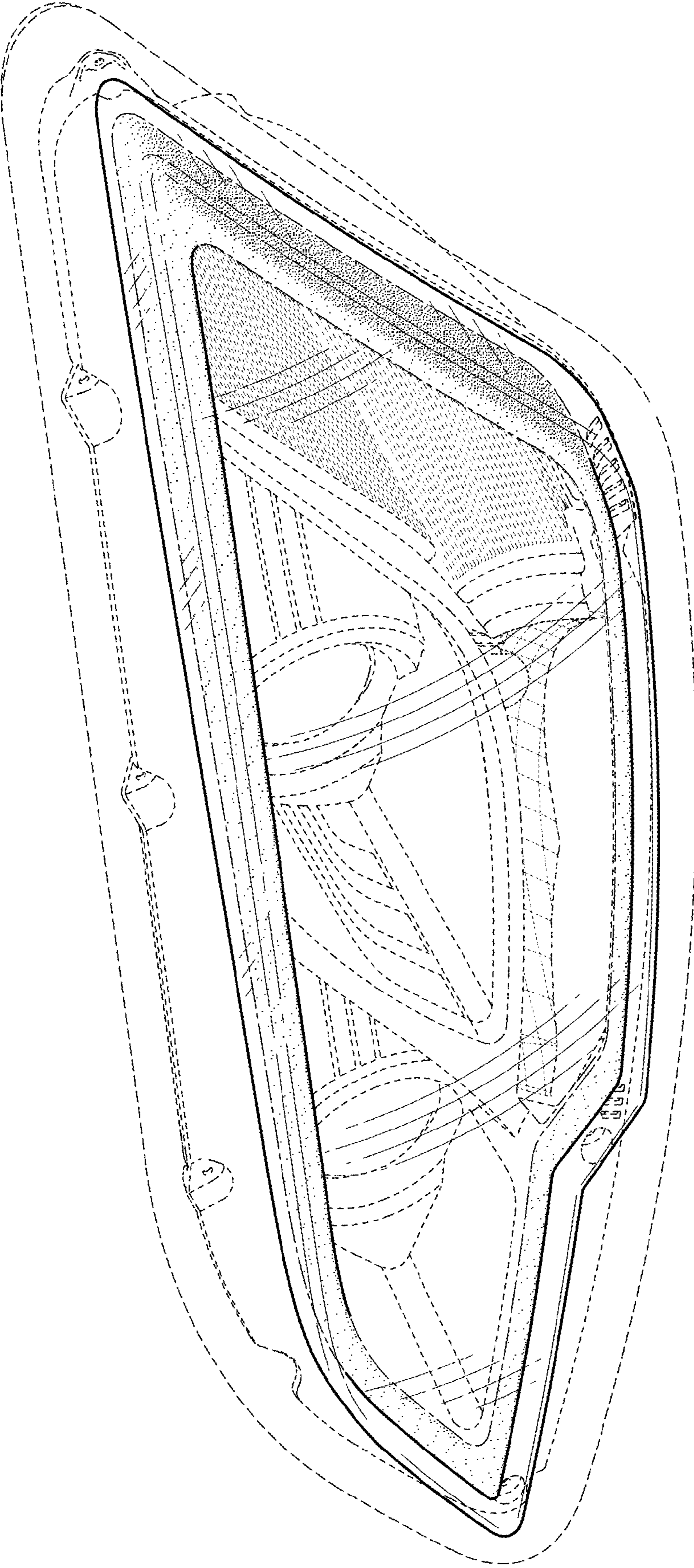


**FIG. 9**

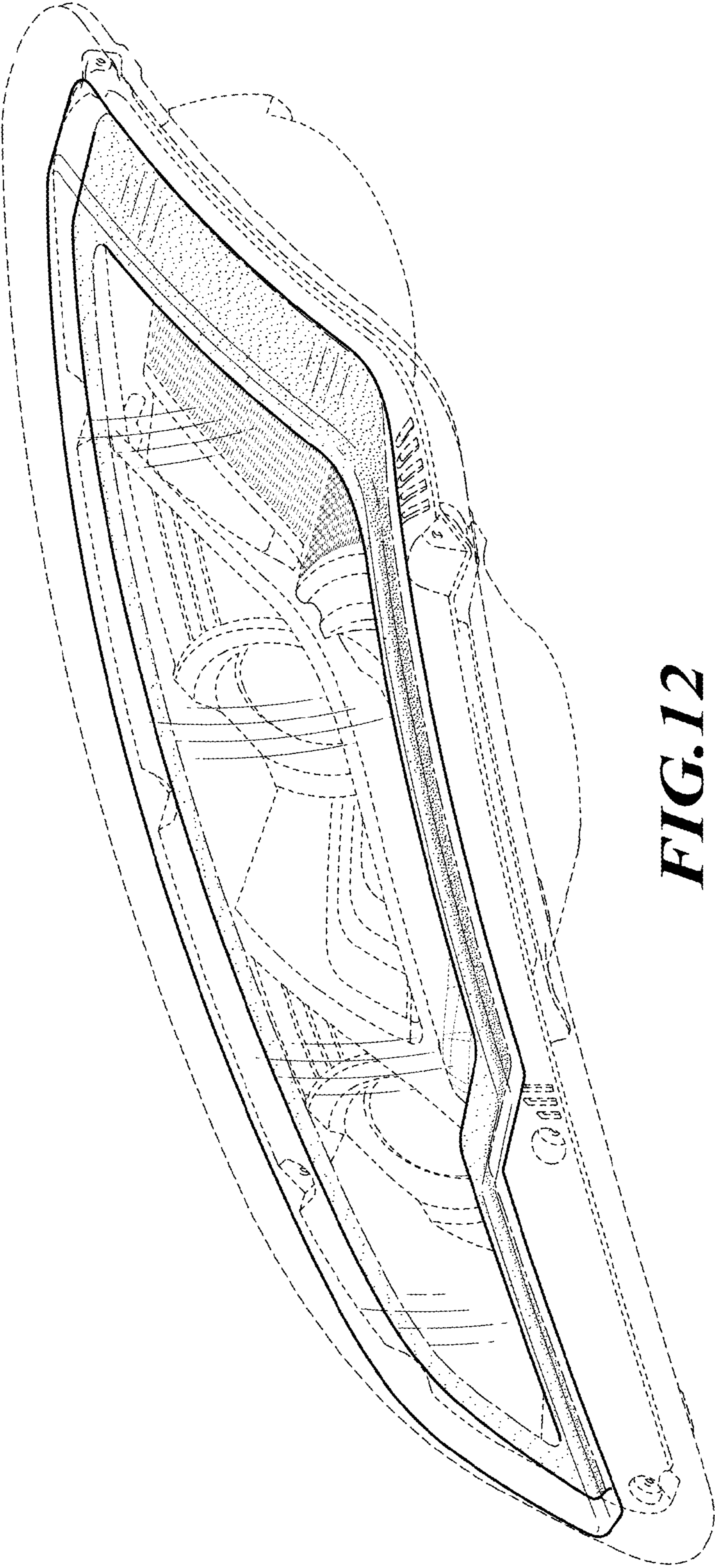




**FIG. 10**

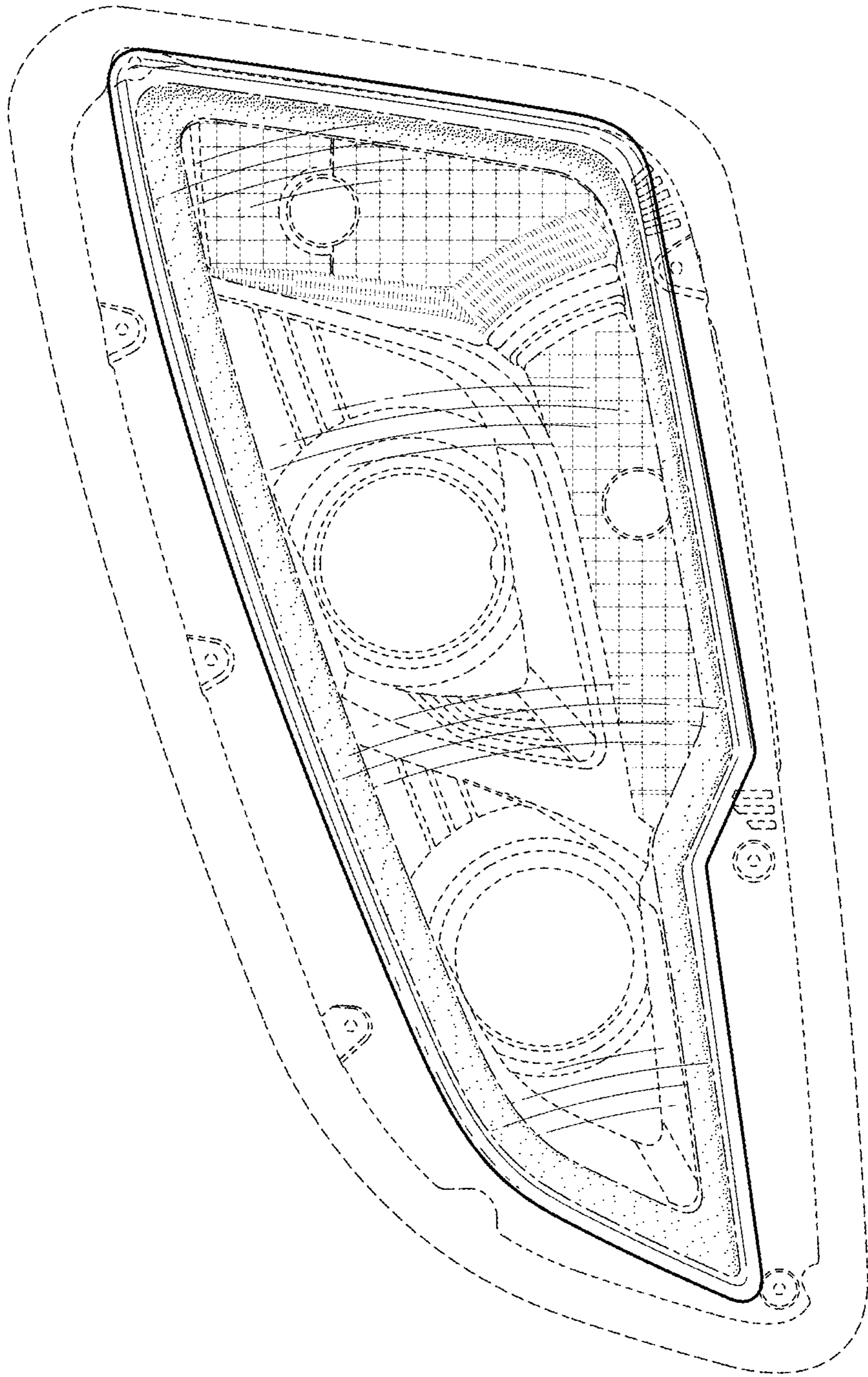


**FIG. 11**

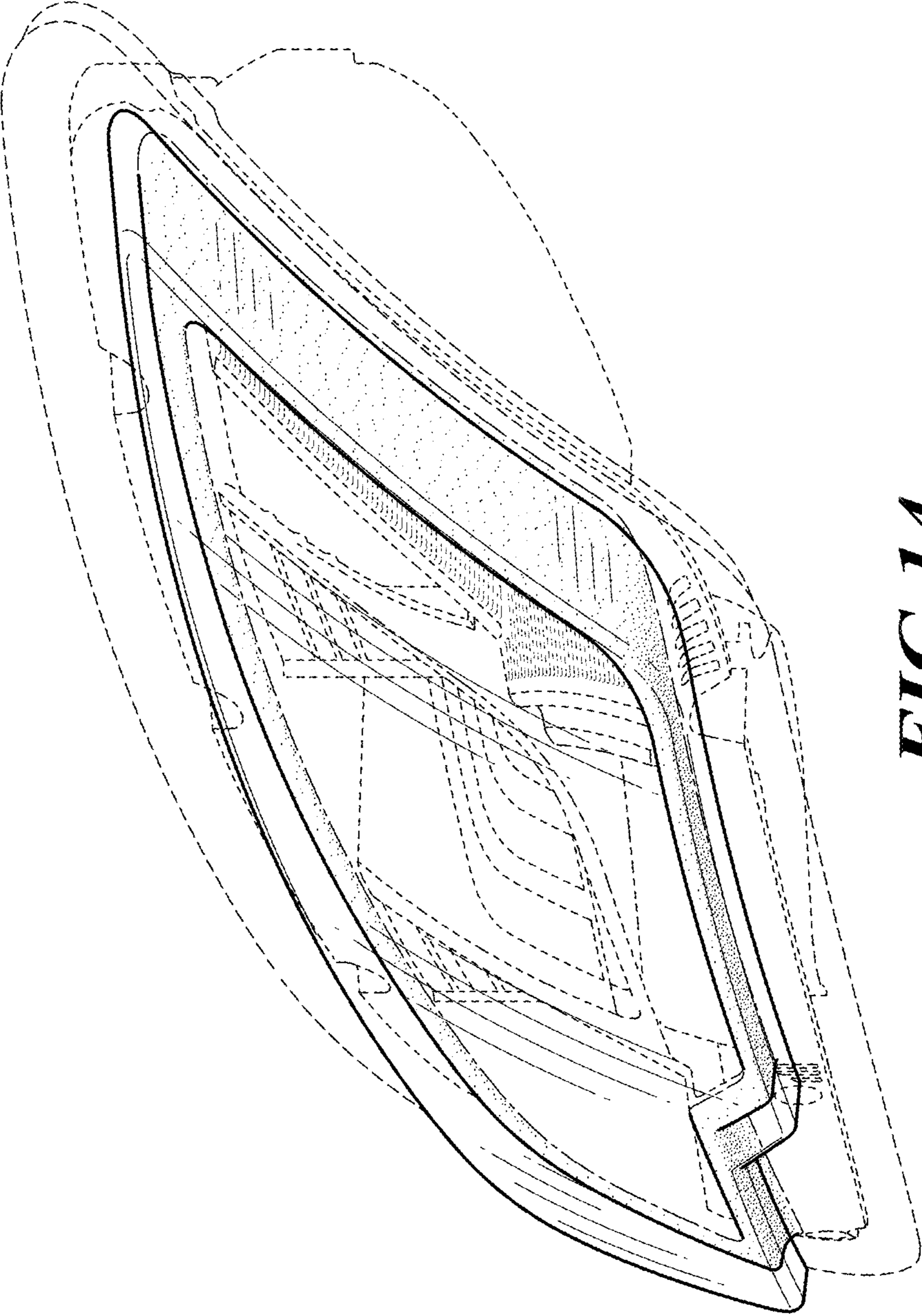


**FIG. 12**

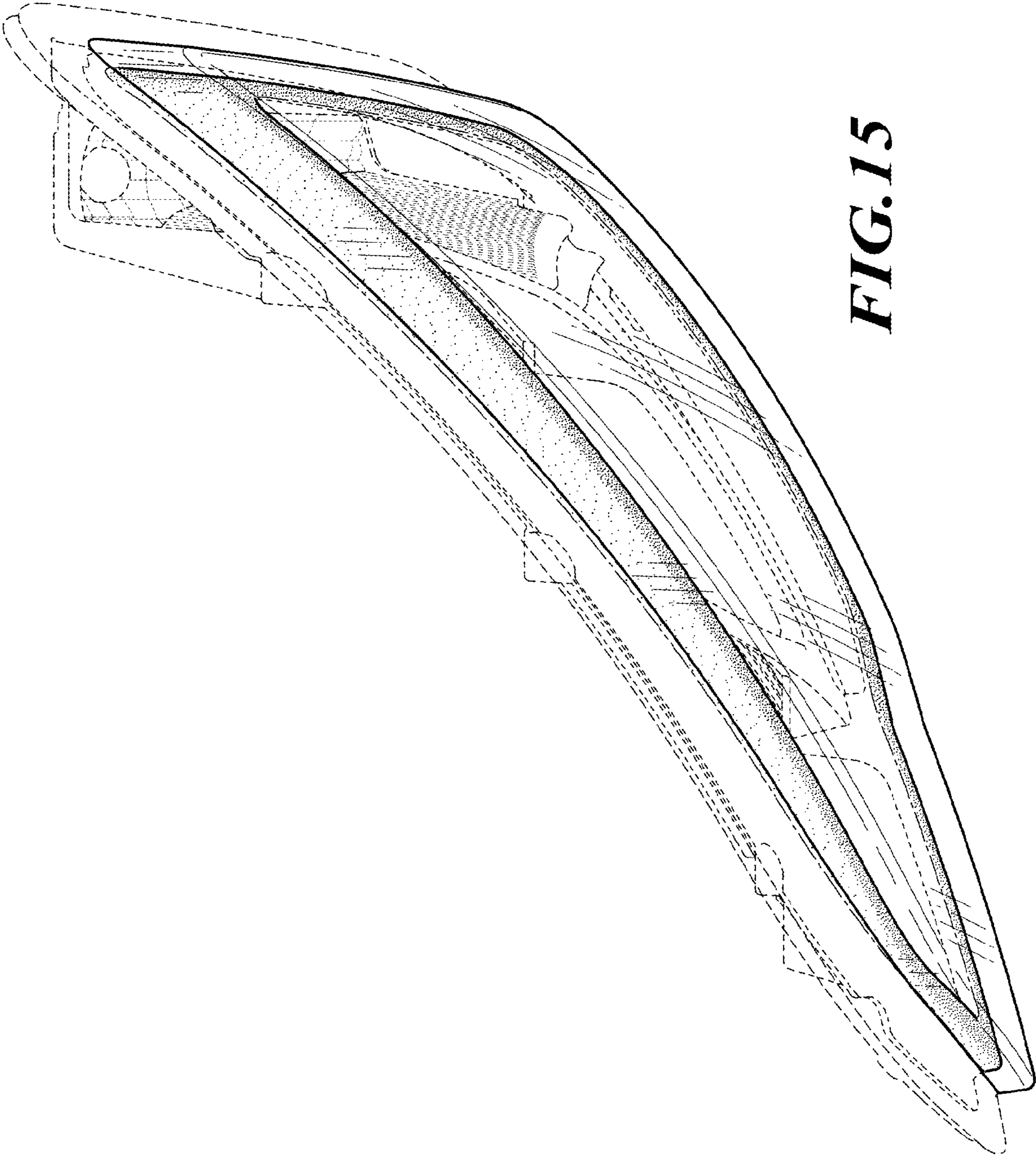




**FIG. 13**

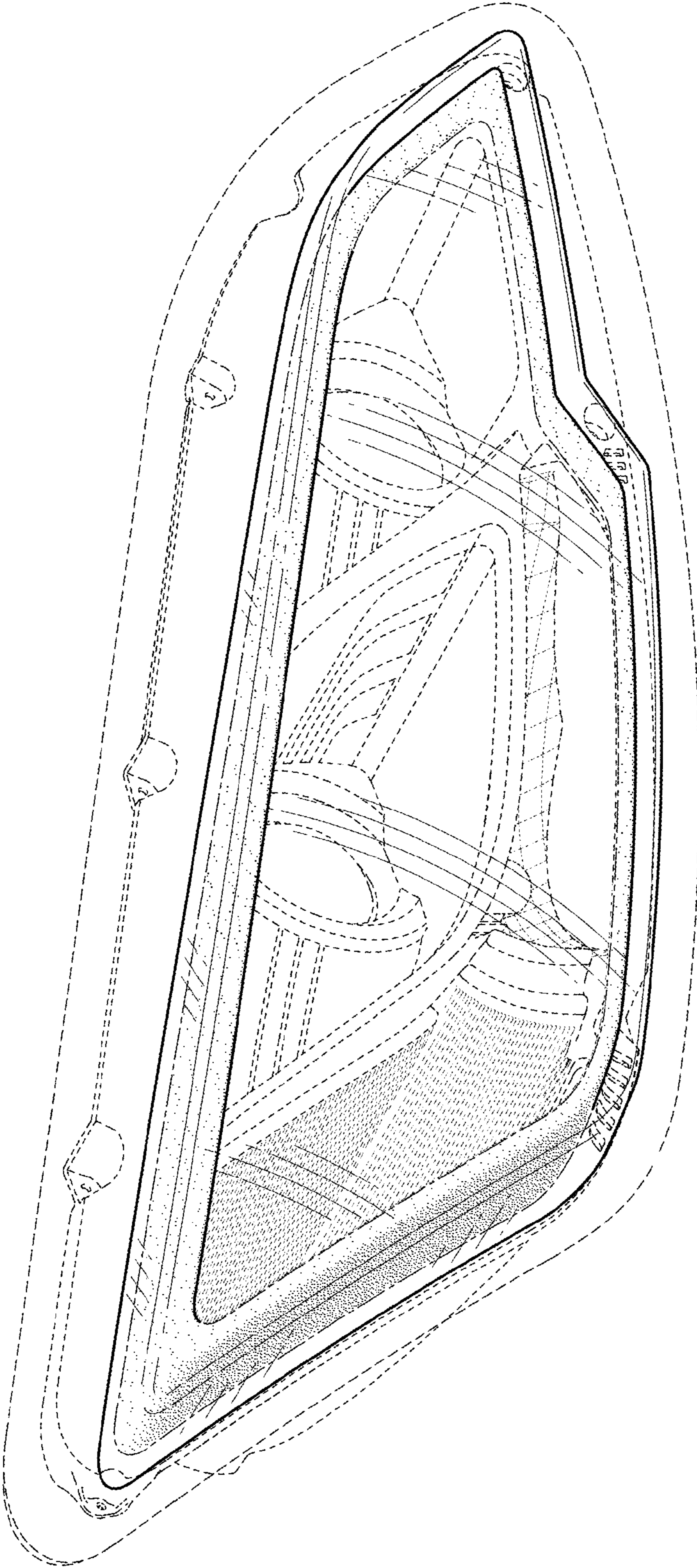


**FIG. 14**

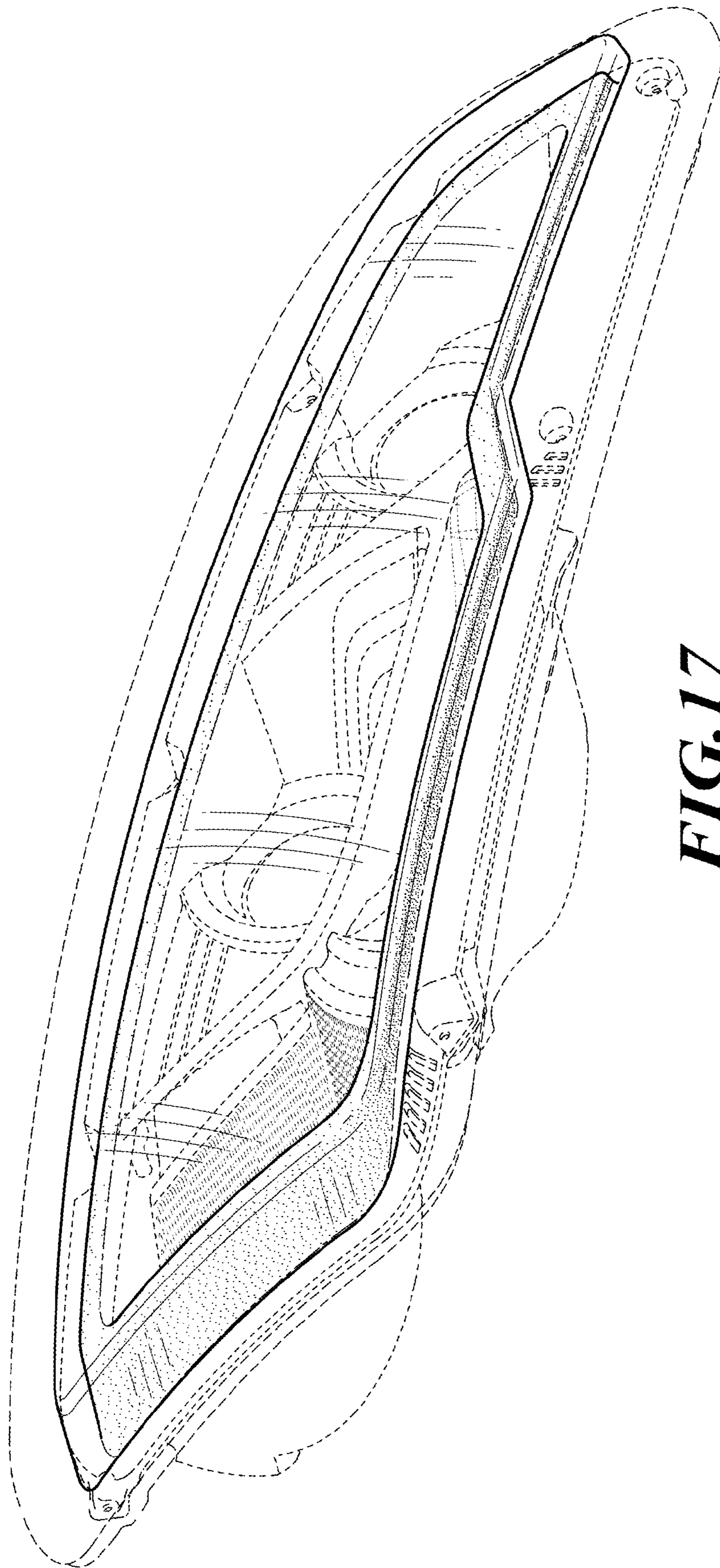


**FIG. 15**

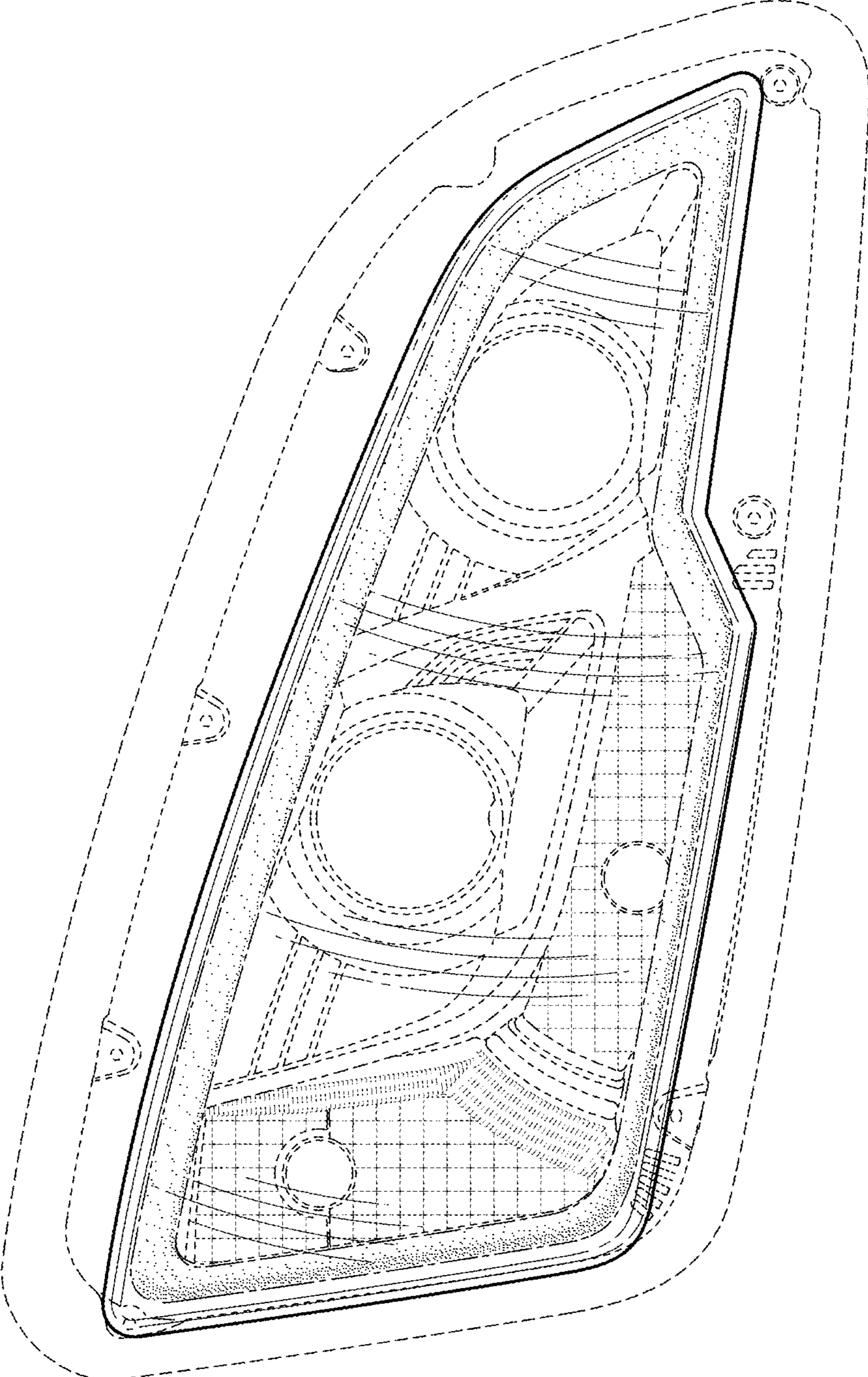




**FIG. 16**

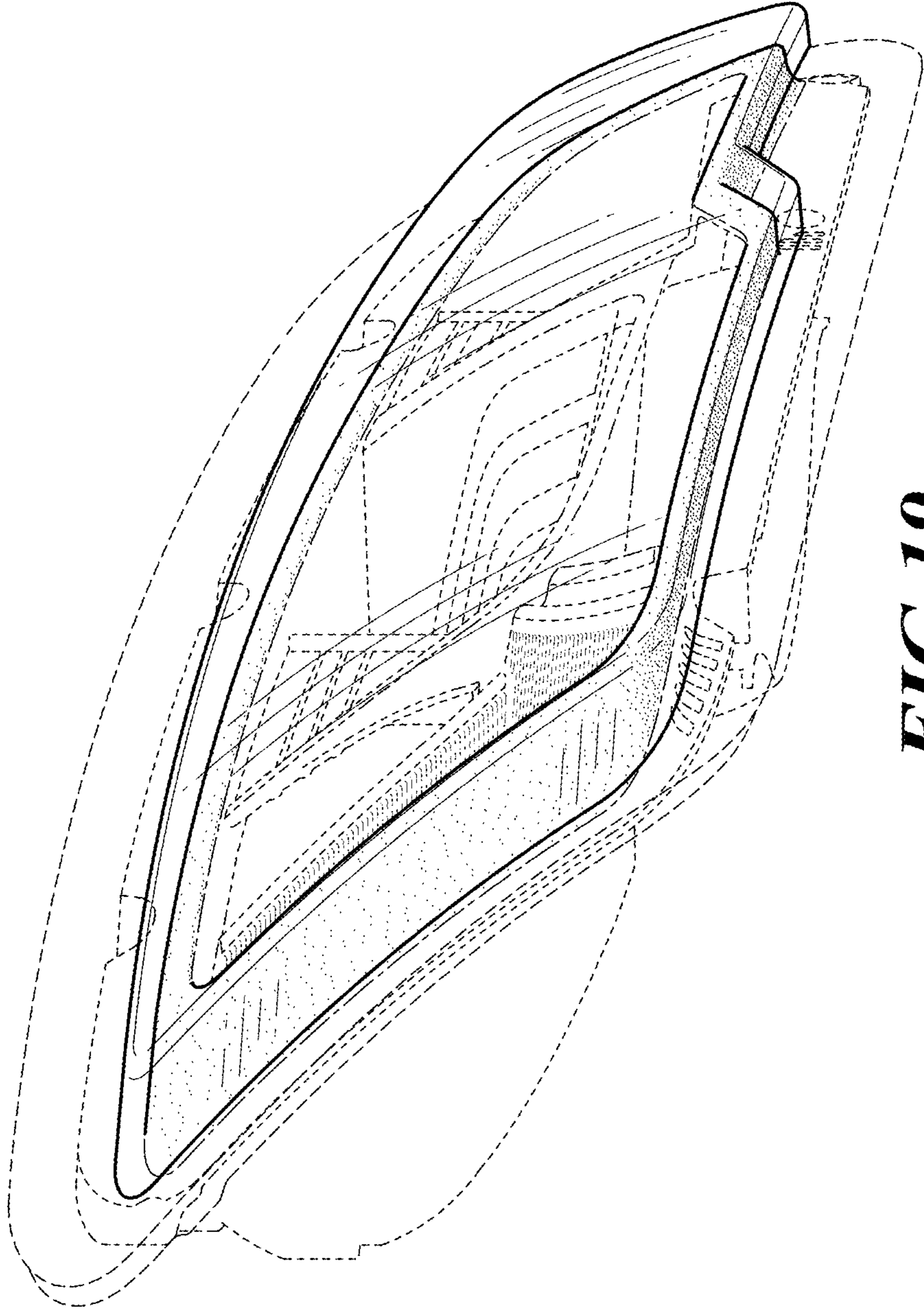


**FIG.17**

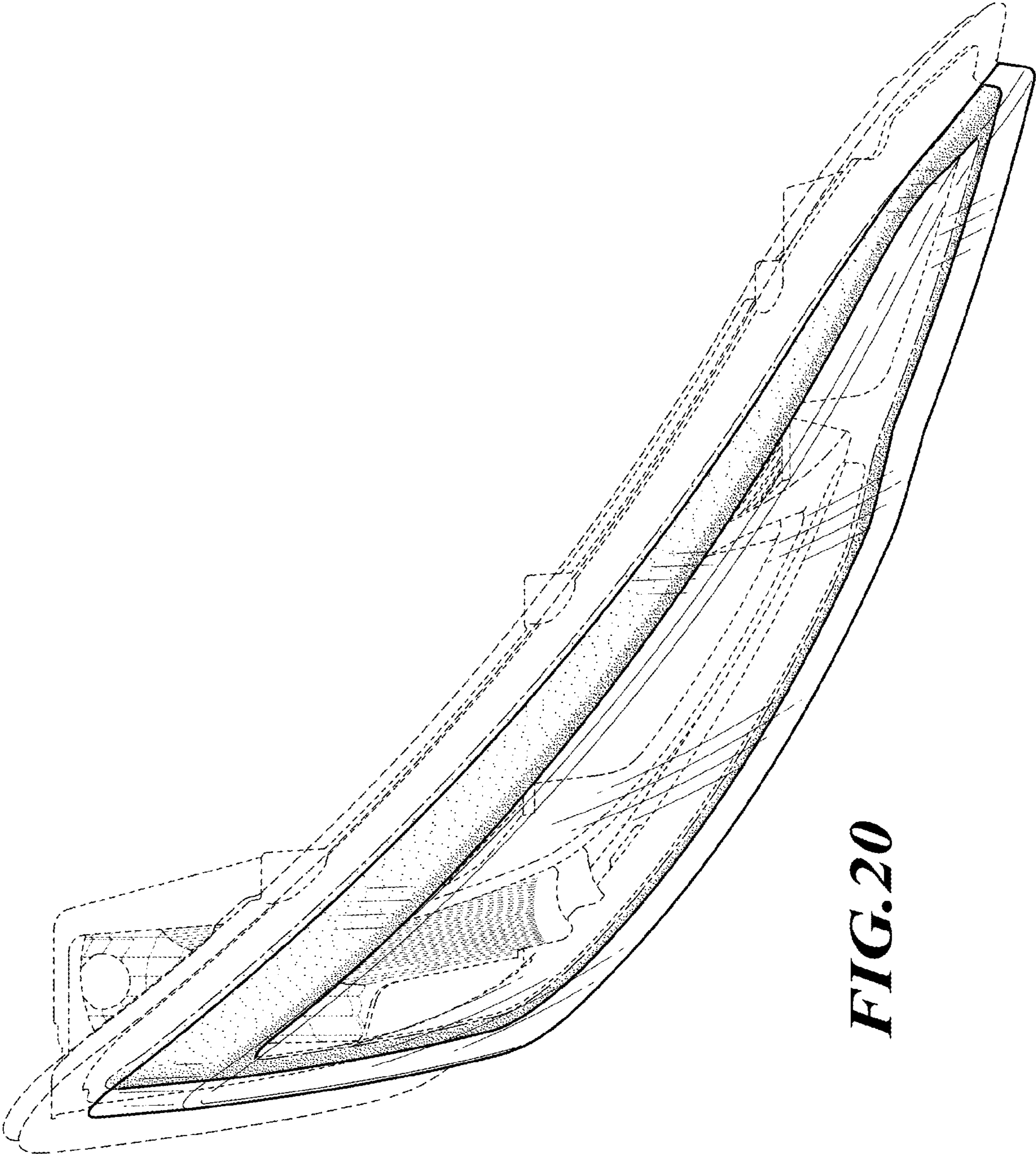


**FIG. 18**





**FIG. 19**



**FIG. 20**