



US0D1028842S

(12) **United States Design Patent**  
**Cunningham**

(10) **Patent No.: US D1,028,842 S**

(45) **Date of Patent: \*\* May 28, 2024**

(54) **VEHICLE RACK**

(71) Applicant: **THI CANADA, INC.**, Oakville (CA)

(72) Inventor: **Michael Cunningham**, Milton (CA)

(73) Assignee: **Extang Corporation**, Ann Arbor, MI (US)

(\*\*) Term: **15 Years**

(21) Appl. No.: **29/884,808**

(22) Filed: **Feb. 16, 2023**

**Related U.S. Application Data**

(62) Division of application No. 29/804,500, filed on Aug. 20, 2021, now Pat. No. Des. 1,009,760.

(51) **LOC (14) Cl.** ..... **12-16**

(52) **U.S. Cl.**  
USPC ..... **D12/222**

(58) **Field of Classification Search**  
USPC ... D12/412, 406, 413, 414, 414.1, 222, 400, D12/223, 180, 191  
CPC ..... B60R 21/02; B60R 21/13; B60R 13/04; B60R 13/005; B60P 3/10; B60P 3/40; B60P 3/1066; B62D 35/001; B60J 7/102  
See application file for complete search history.

(56) **References Cited**

**U.S. PATENT DOCUMENTS**

D381,306 S *	7/1997	Sauerwein	.....	D12/190
6,983,968 B2	1/2006	Brauer et al.		
6,983,977 B1 *	1/2006	Kozak	.....	B62D 35/001 296/180.1
D528,964 S *	9/2006	Storer	.....	D12/222
D528,968 S	9/2006	Storer et al.		
D644,591 S *	9/2011	Andonian	.....	D12/406
8,668,124 B2	3/2014	Kennedy et al.		
D763,170 S	8/2016	Marankie		
9,713,978 B2	7/2017	Petru		

10,046,691 B2	8/2018	Petru		
D840,905 S	2/2019	Parzyck et al.		
D841,558 S *	2/2019	Mosingo	.....	D12/222
D845,869 S *	4/2019	Wymore	.....	D12/222
D857,605 S	8/2019	Mosingo et al.		
10,414,369 B2	9/2019	Parzyck et al.		
D861,575 S	10/2019	Tang		
D866,447 S	11/2019	Ash		

(Continued)

*Primary Examiner* — Susan E Krakower

*Assistant Examiner* — Jerry Shiuian-Hua Hsu

(74) *Attorney, Agent, or Firm* — The Dobrusin Law Firm, P.C.

(57) **CLAIM**

The ornamental design for a vehicle rack, as shown and described.

**DESCRIPTION**

FIG. 1 is a top, front, left side perspective view of a first embodiment of the present design.  
 FIG. 2 is a top, back, left side view thereof.  
 FIG. 3 is a front elevational view thereof.  
 FIG. 4 is a top plan view thereof.  
 FIG. 5 is a left side elevational view thereof.  
 FIG. 6 is a right side elevational view thereof.  
 FIG. 7 is a back elevational view thereof.  
 FIG. 8 is a bottom plan view thereof.  
 FIG. 9 is a top, front, left side perspective view of a second embodiment of the present design.  
 FIG. 10 is a top, back, left side perspective view thereof.  
 FIG. 11 is a front elevational view of thereof.  
 FIG. 12 is a top plan view thereof;  
 FIG. 13 is a left side elevational view thereof.  
 FIG. 14 is a right side elevational view thereof.  
 FIG. 15 is a back elevational view thereof; and,  
 FIG. 16 is a bottom plan view thereof.  
 The broken lines are used to show unclaimed portions of the vehicle rack and form no part of the claimed design.

**1 Claim, 14 Drawing Sheets**

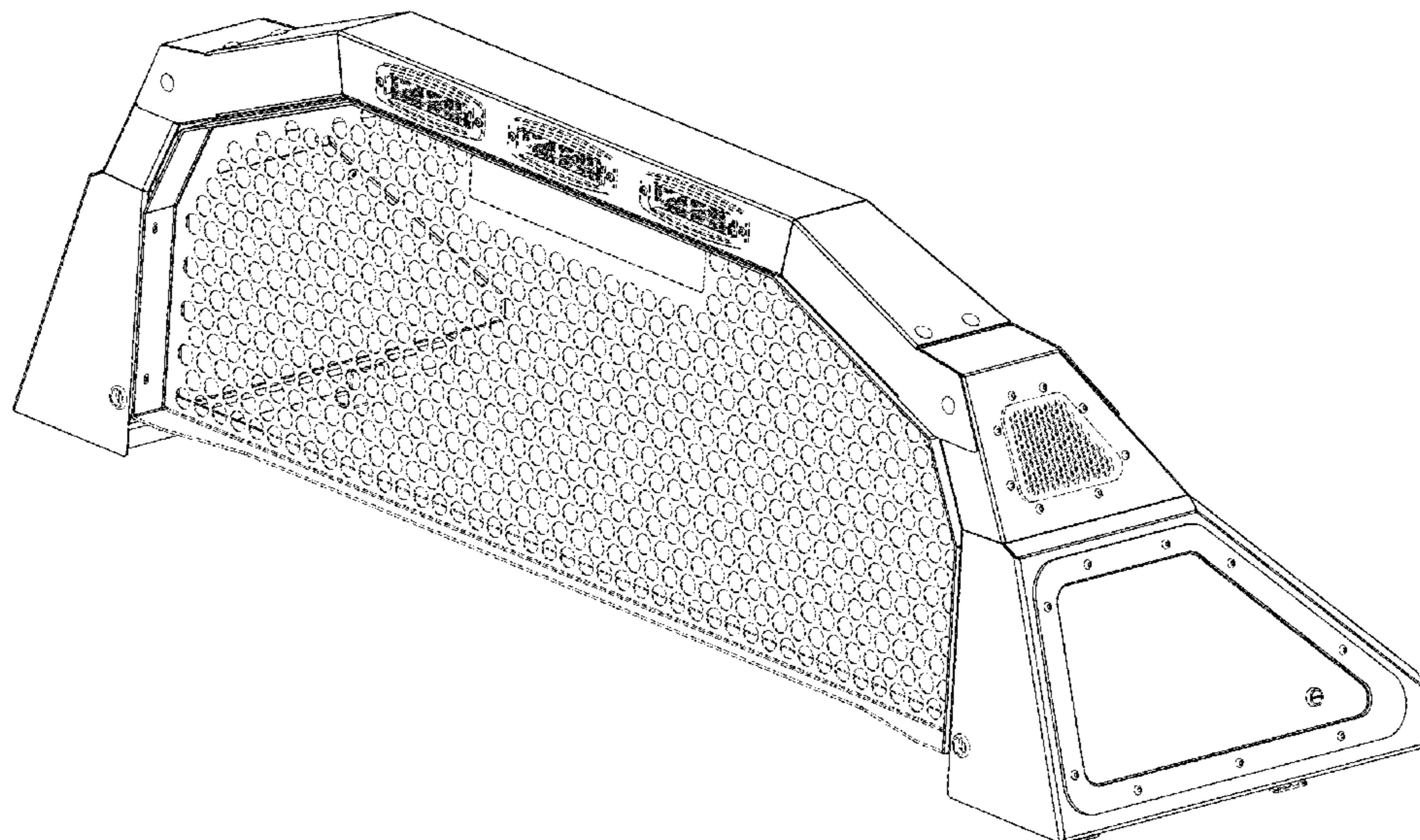

(56)

**References Cited**

U.S. PATENT DOCUMENTS

D881,785	S	4/2020	Ajam et al.	
D883,176	S	5/2020	Ajam et al.	
D892,024	S	8/2020	Li	
D920,883	S	6/2021	Yung	
D933,576	S	10/2021	Ajam	
D944,176	S	2/2022	Yung	
D947,747	S	4/2022	Yung	
D965,500	S	10/2022	Tang	
D965,501	S	10/2022	Tang	
D992,474	S *	7/2023	Willing .....	D12/181
2003/0011180	A1	1/2003	Coffman et al.	
2007/0176447	A1 *	8/2007	Storer .....	B60R 13/005 296/3
2014/0125044	A1 *	5/2014	Mantovani .....	B60R 21/13 280/756
2018/0072244	A1 *	3/2018	Wymore .....	B60R 13/04
2018/0111565	A1 *	4/2018	Wymore .....	B60J 7/102
2018/0118148	A1 *	5/2018	Parzyck .....	B60R 21/02

\* cited by examiner



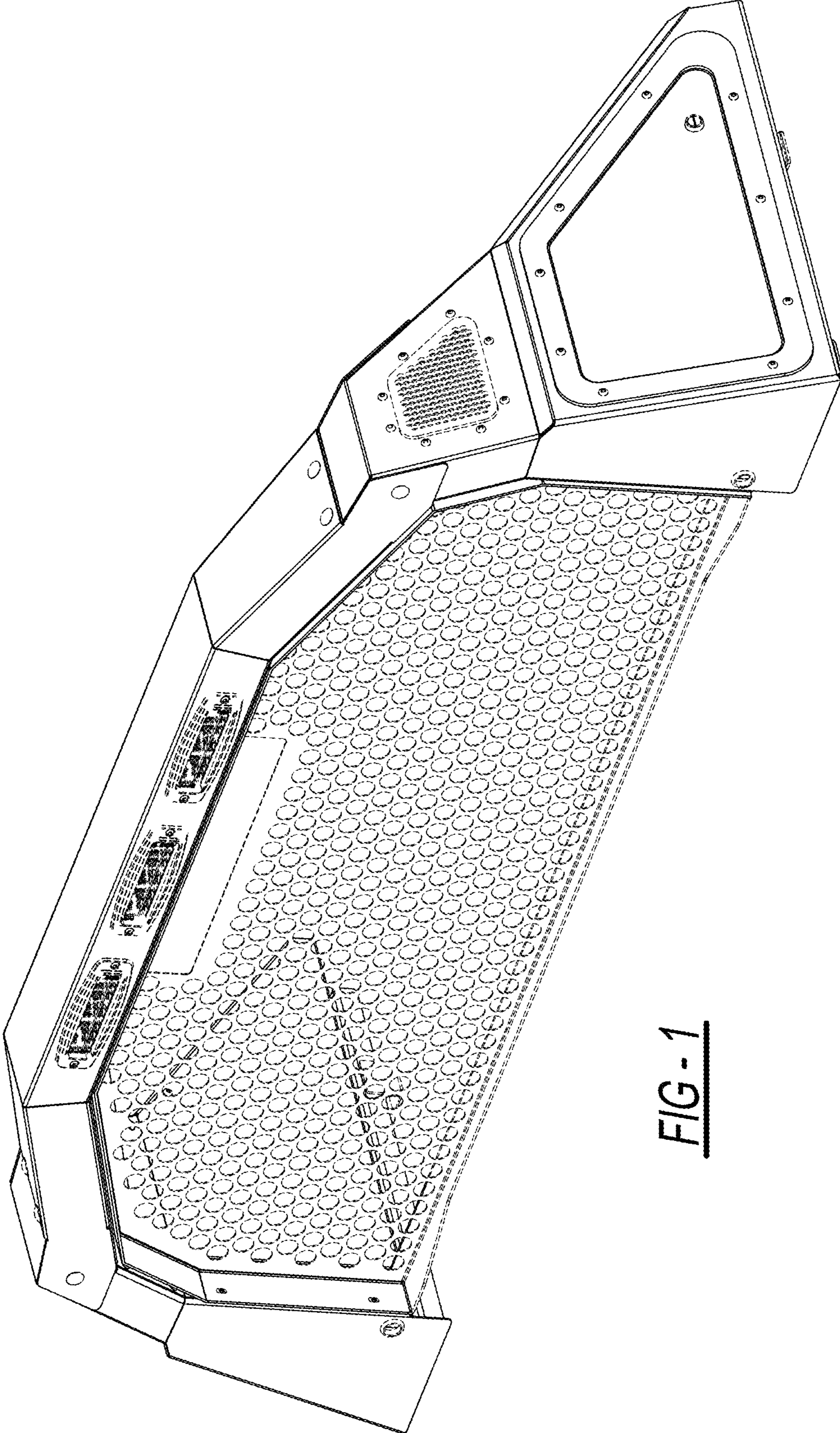

FIG - 1

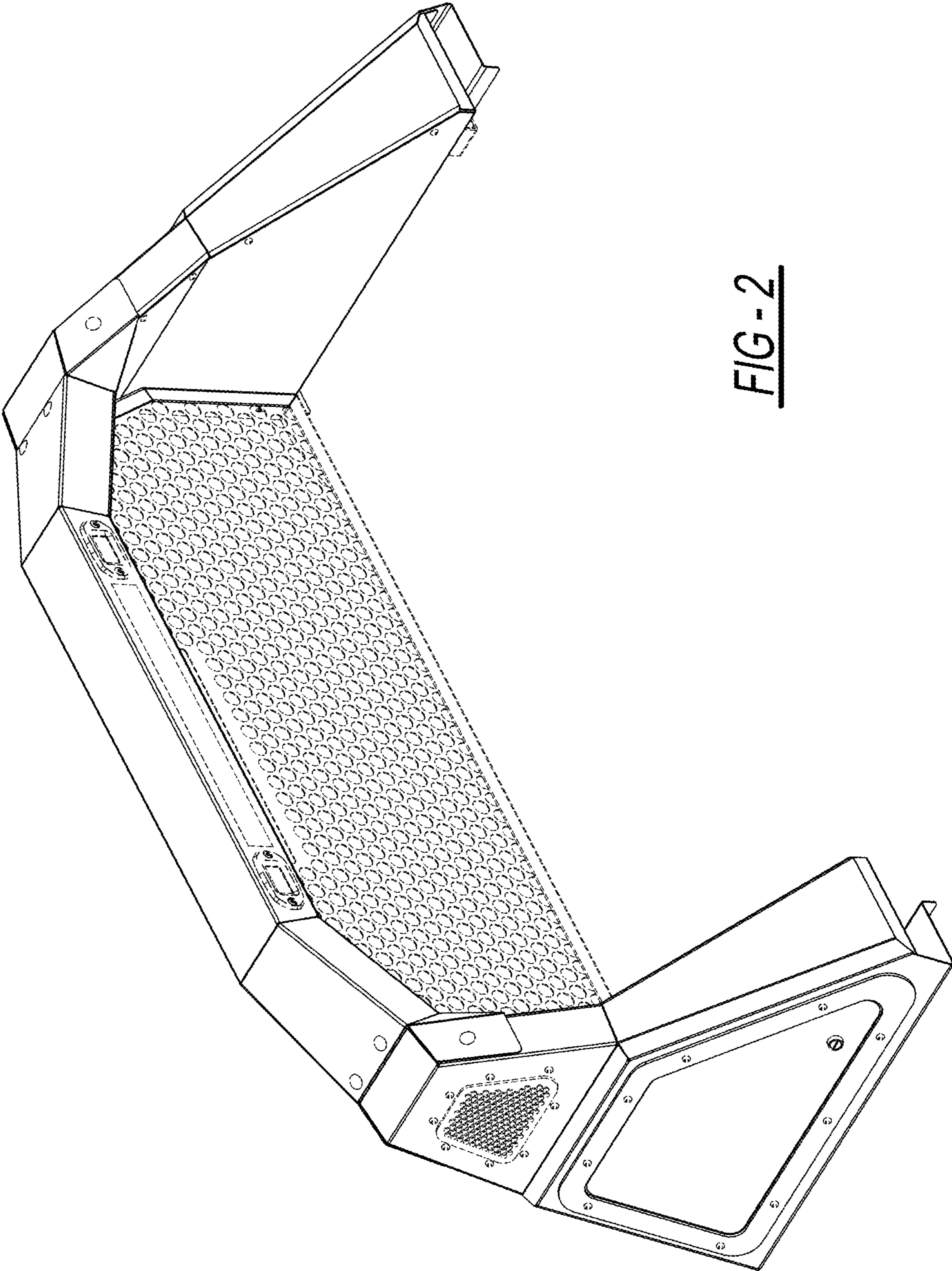

FIG - 2



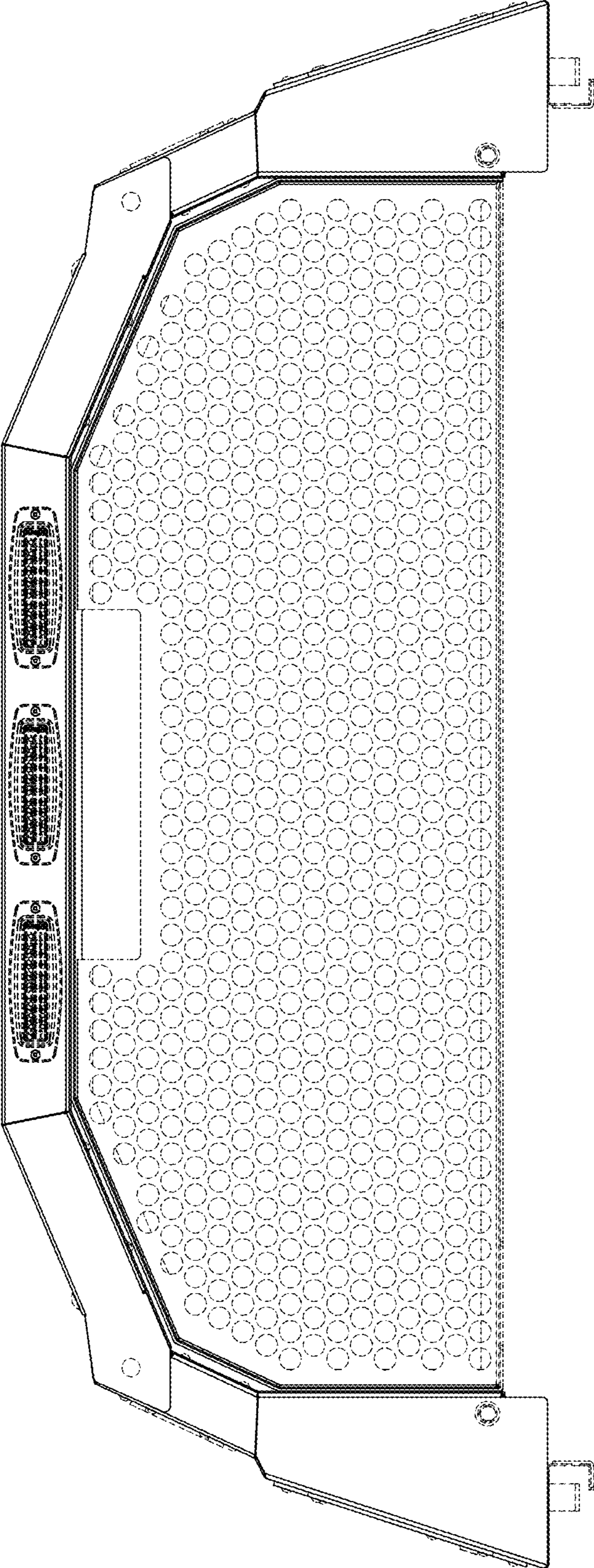

FIG - 3

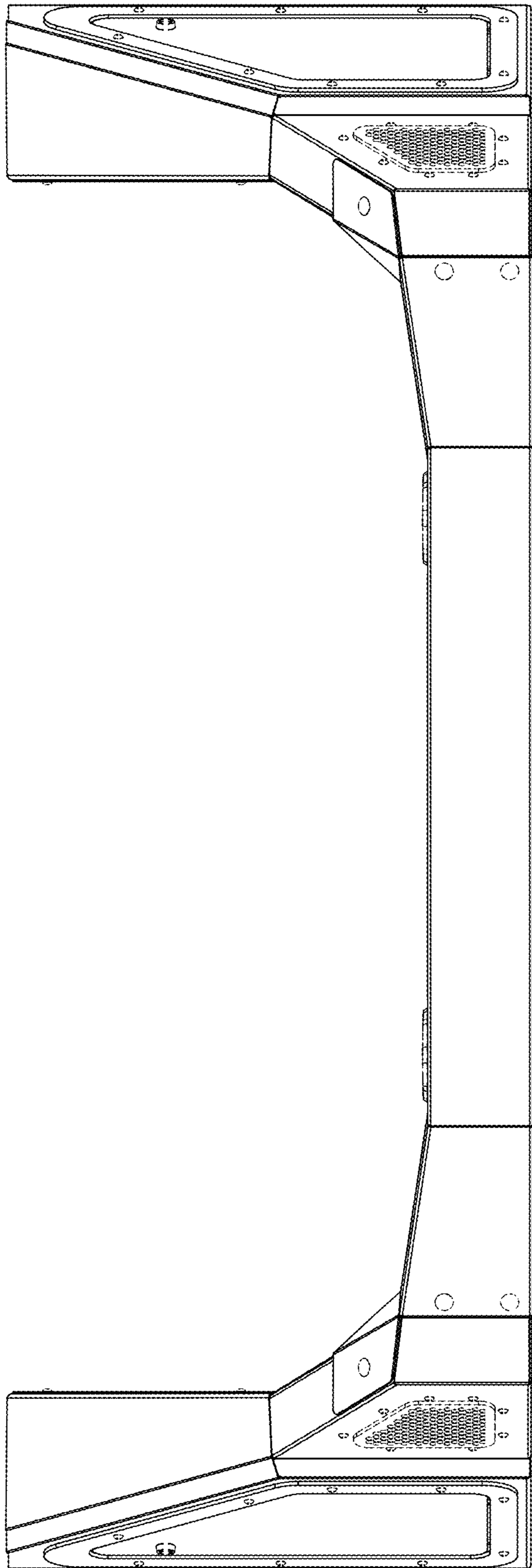

FIG - 4

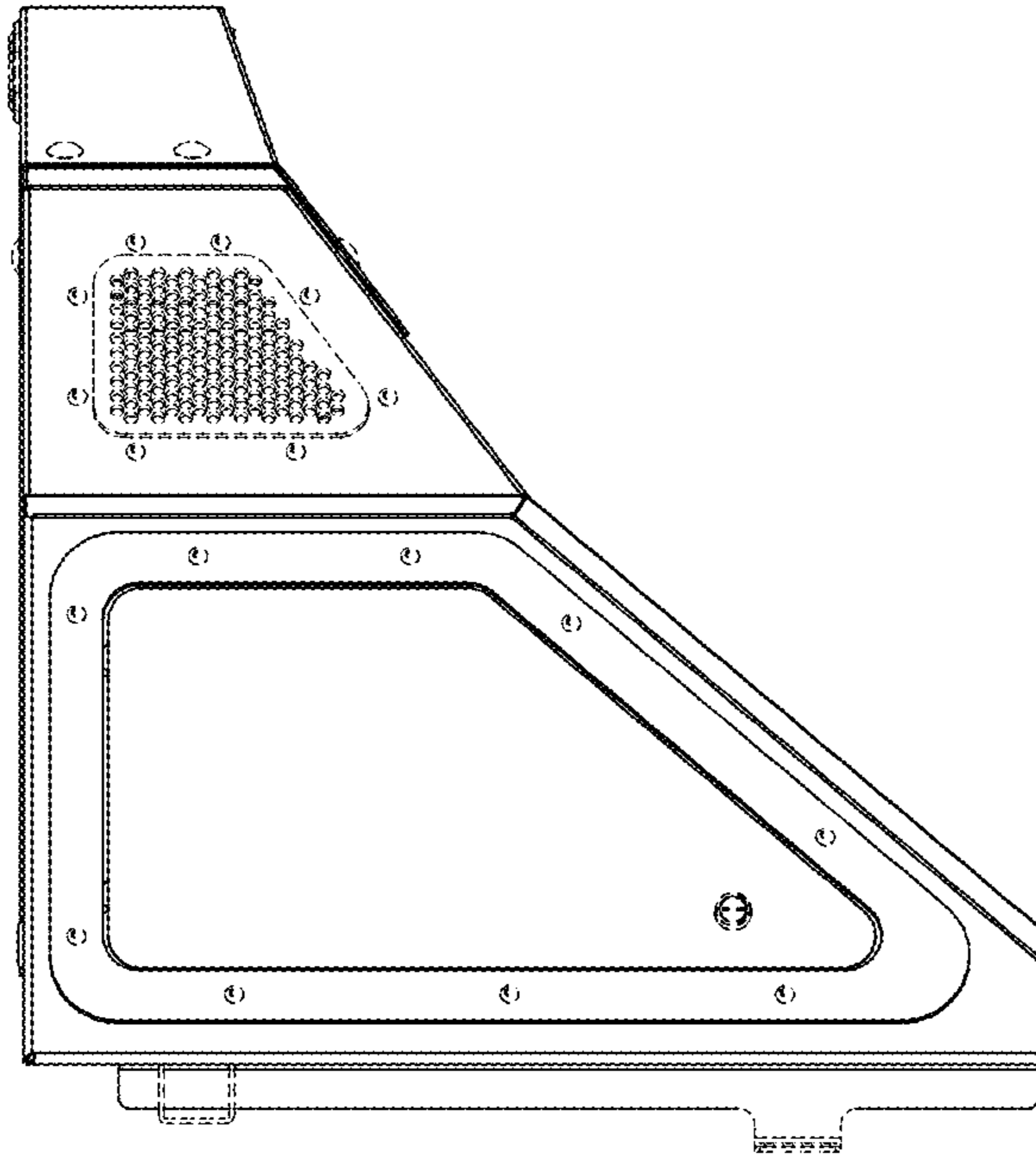
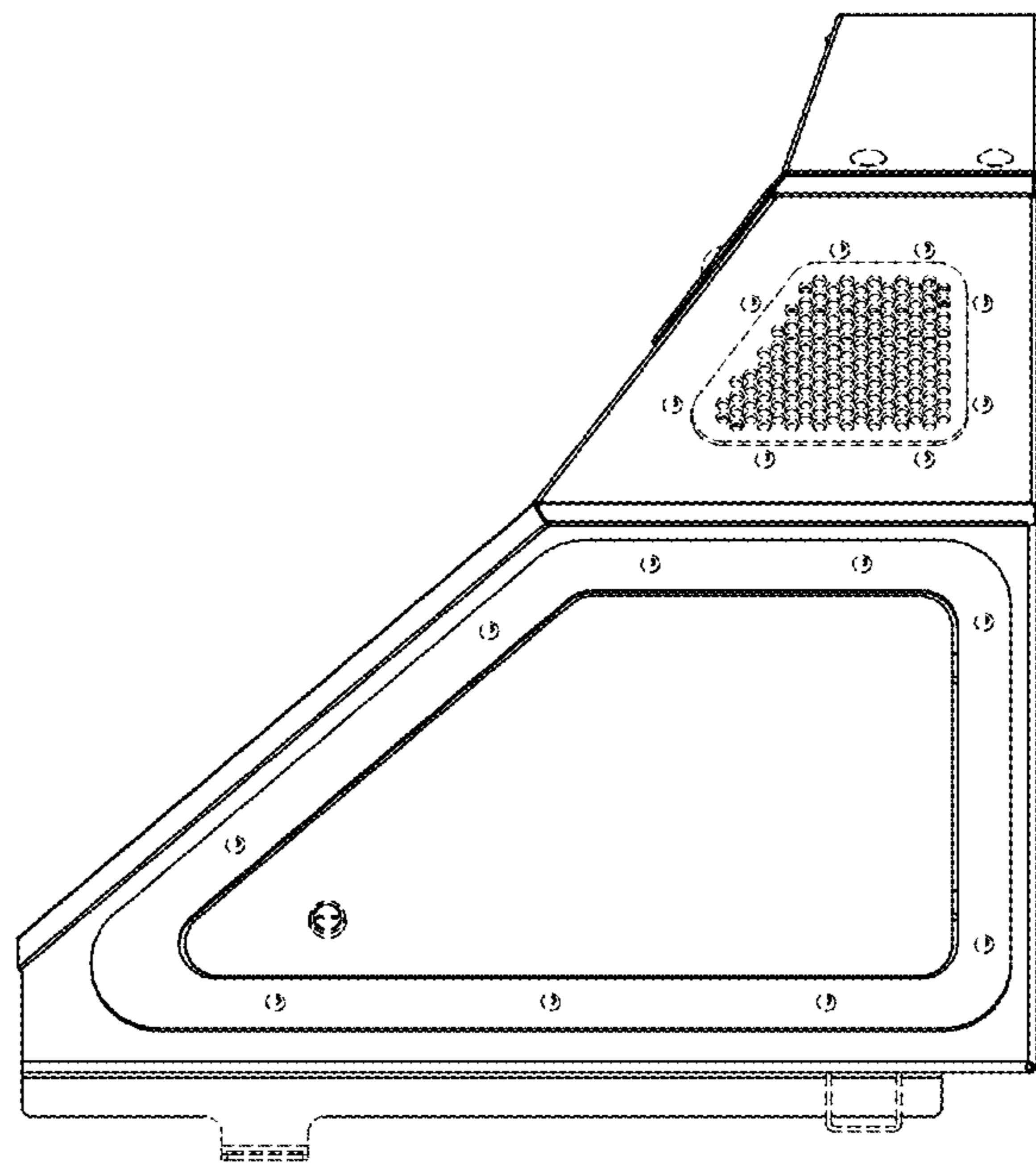

FIG - 5

FIG - 6





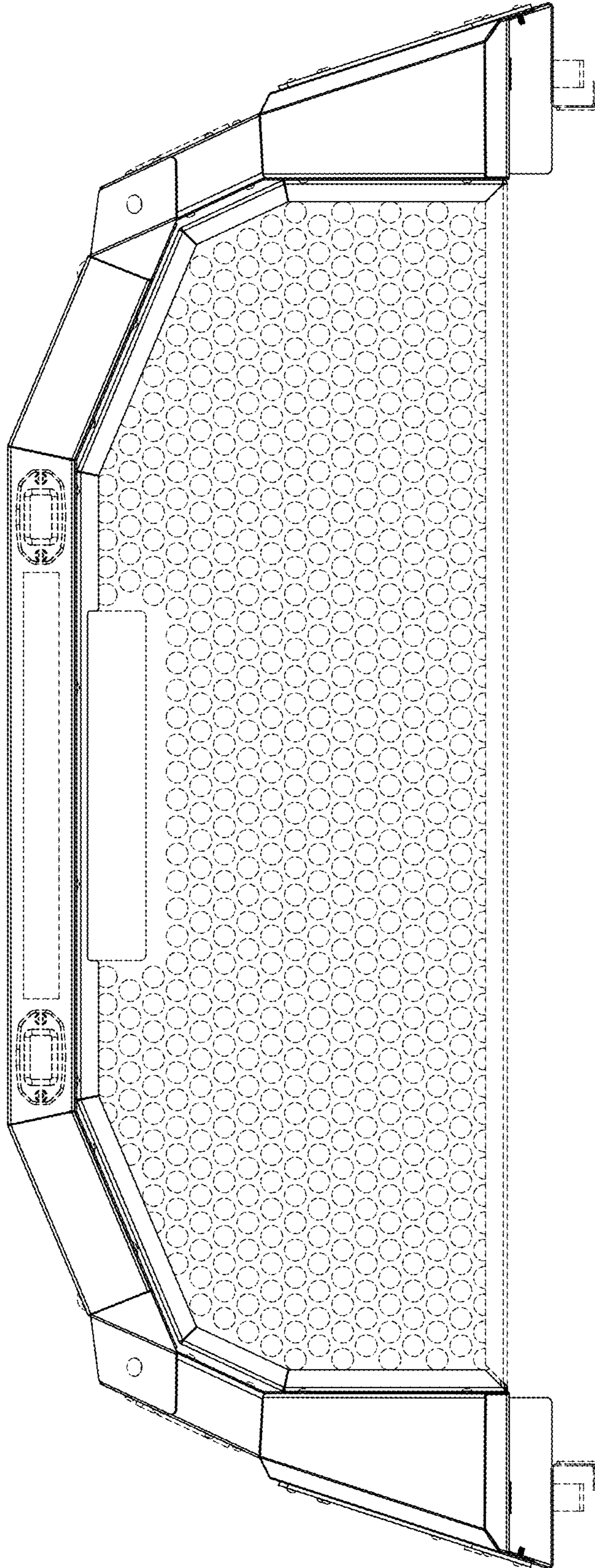

FIG-7



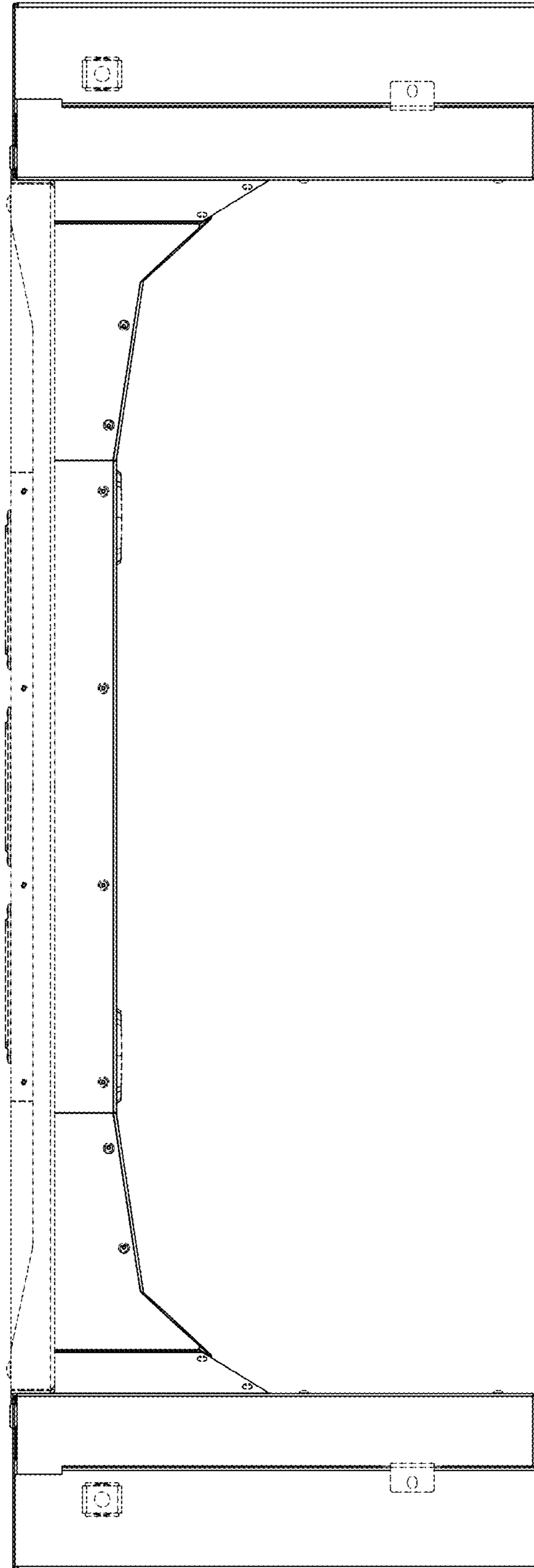

FIG-8

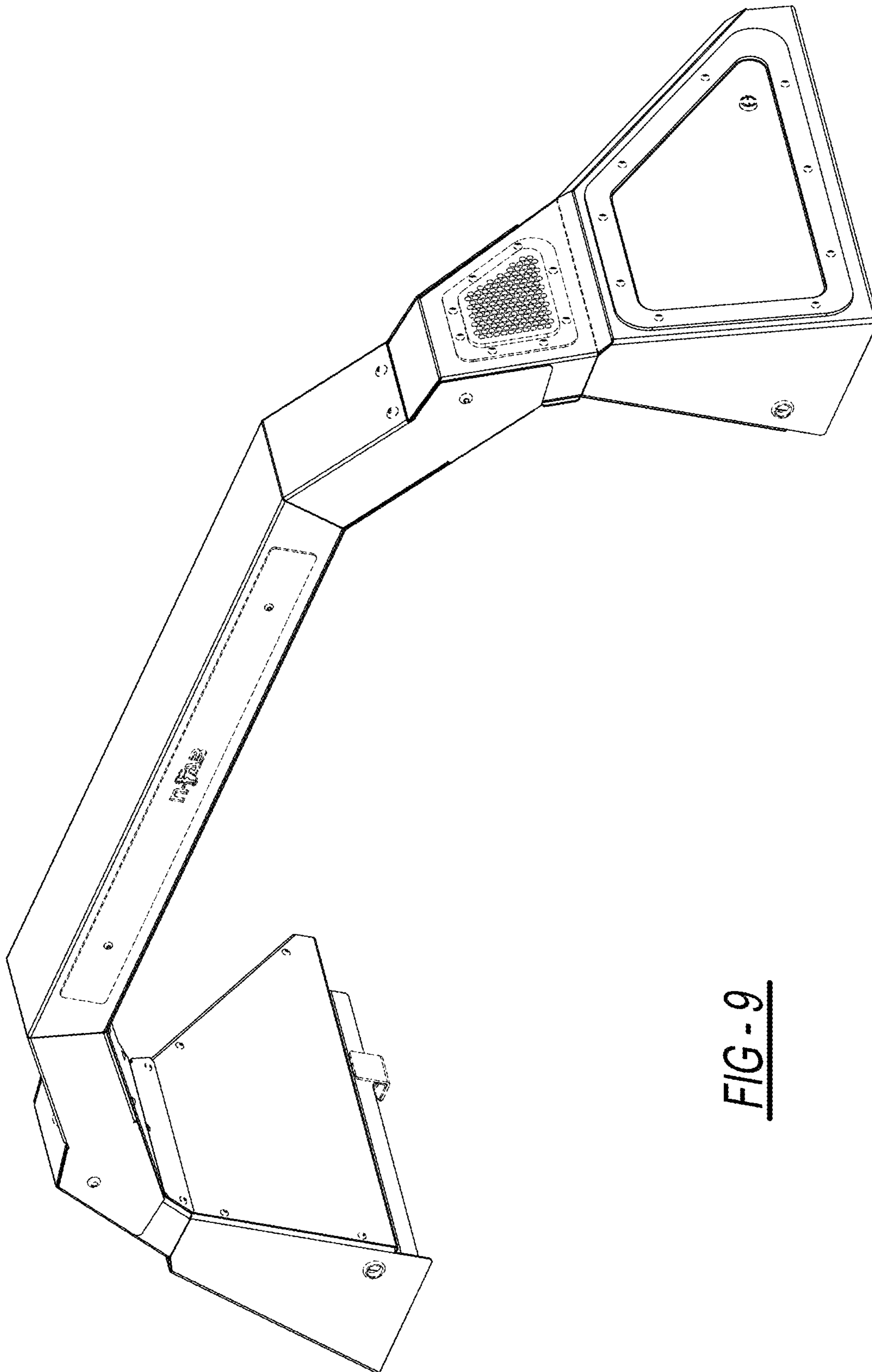

FIG - 9



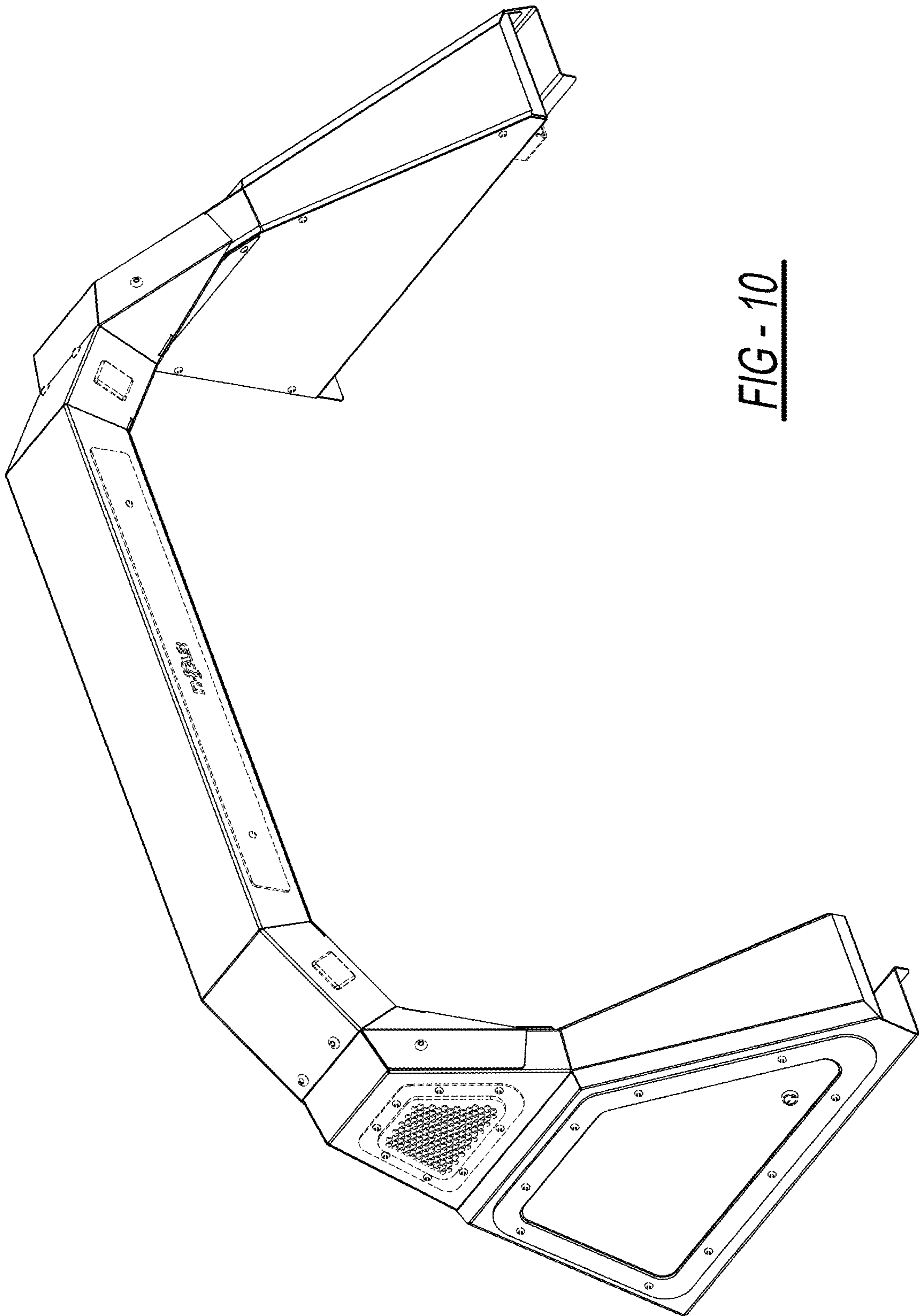

FIG - 10

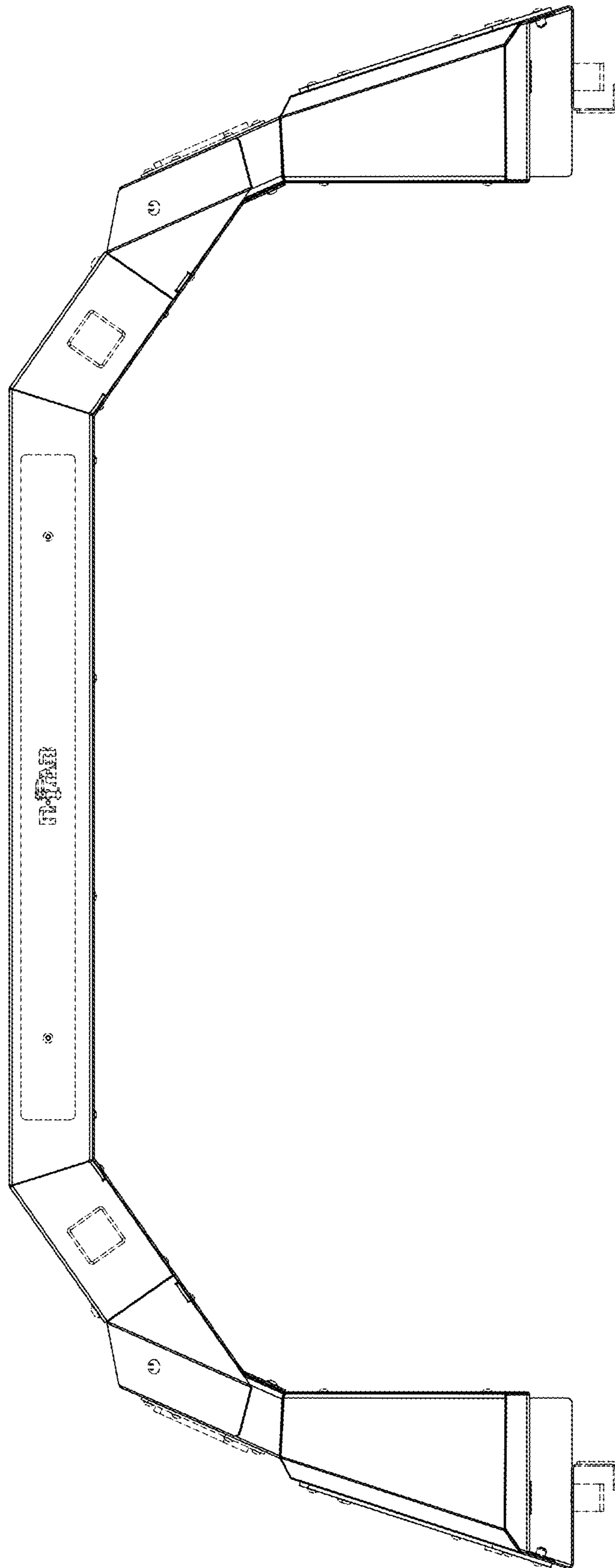

FIG - 11



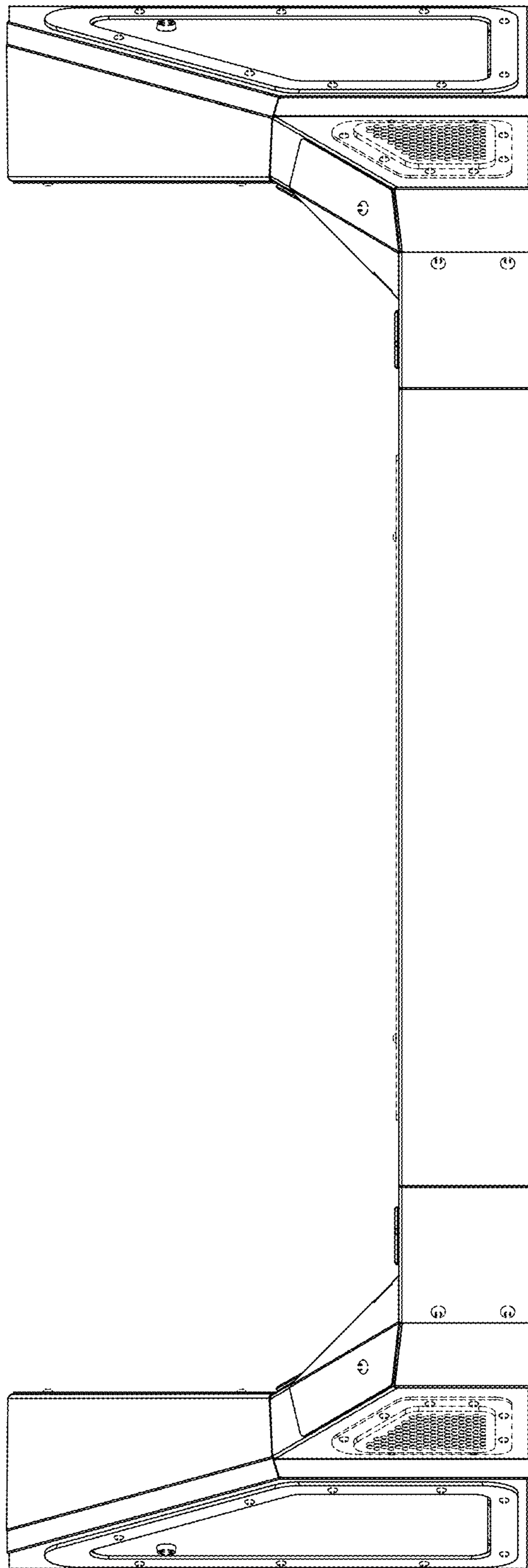

FIG - 12

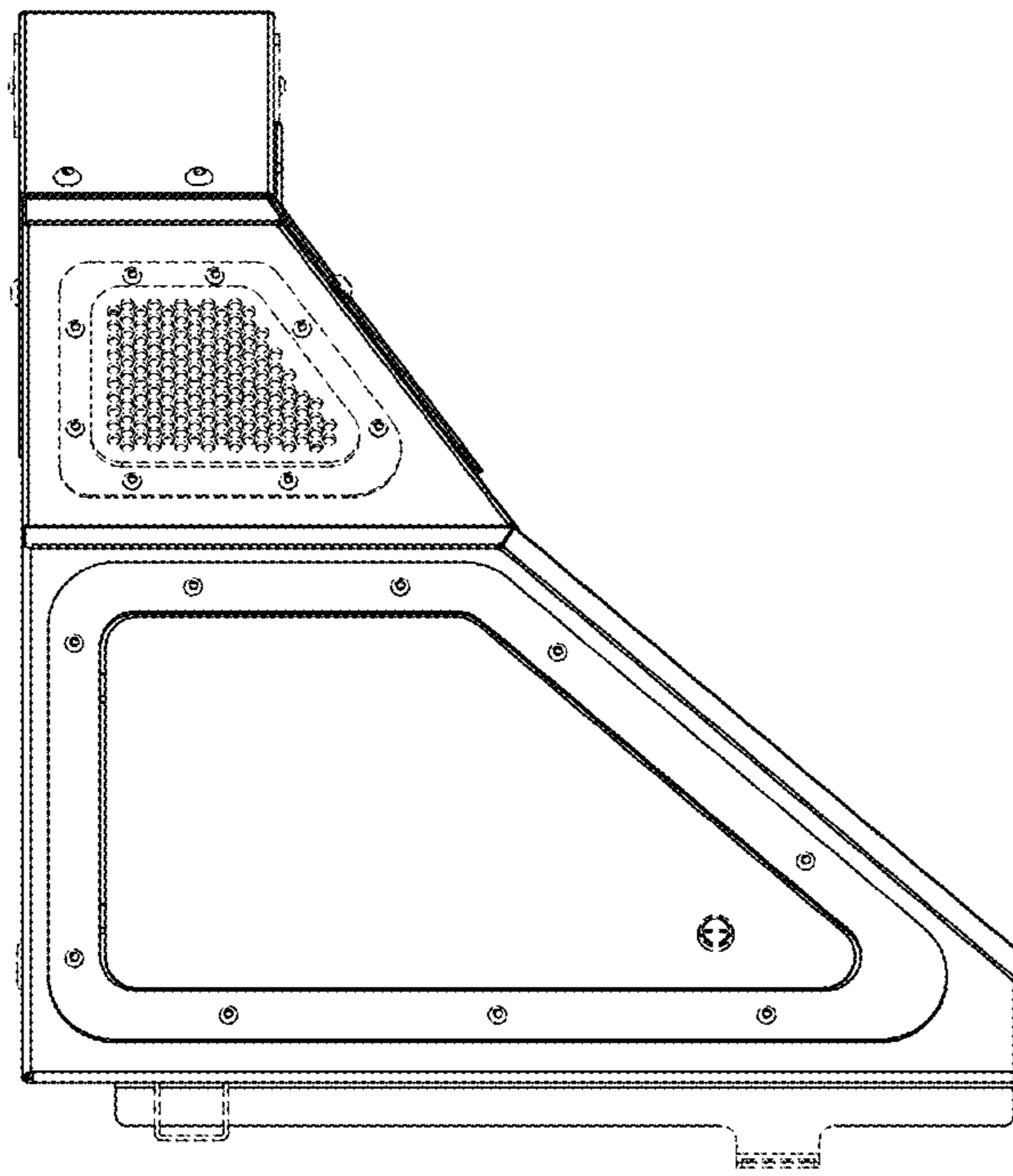
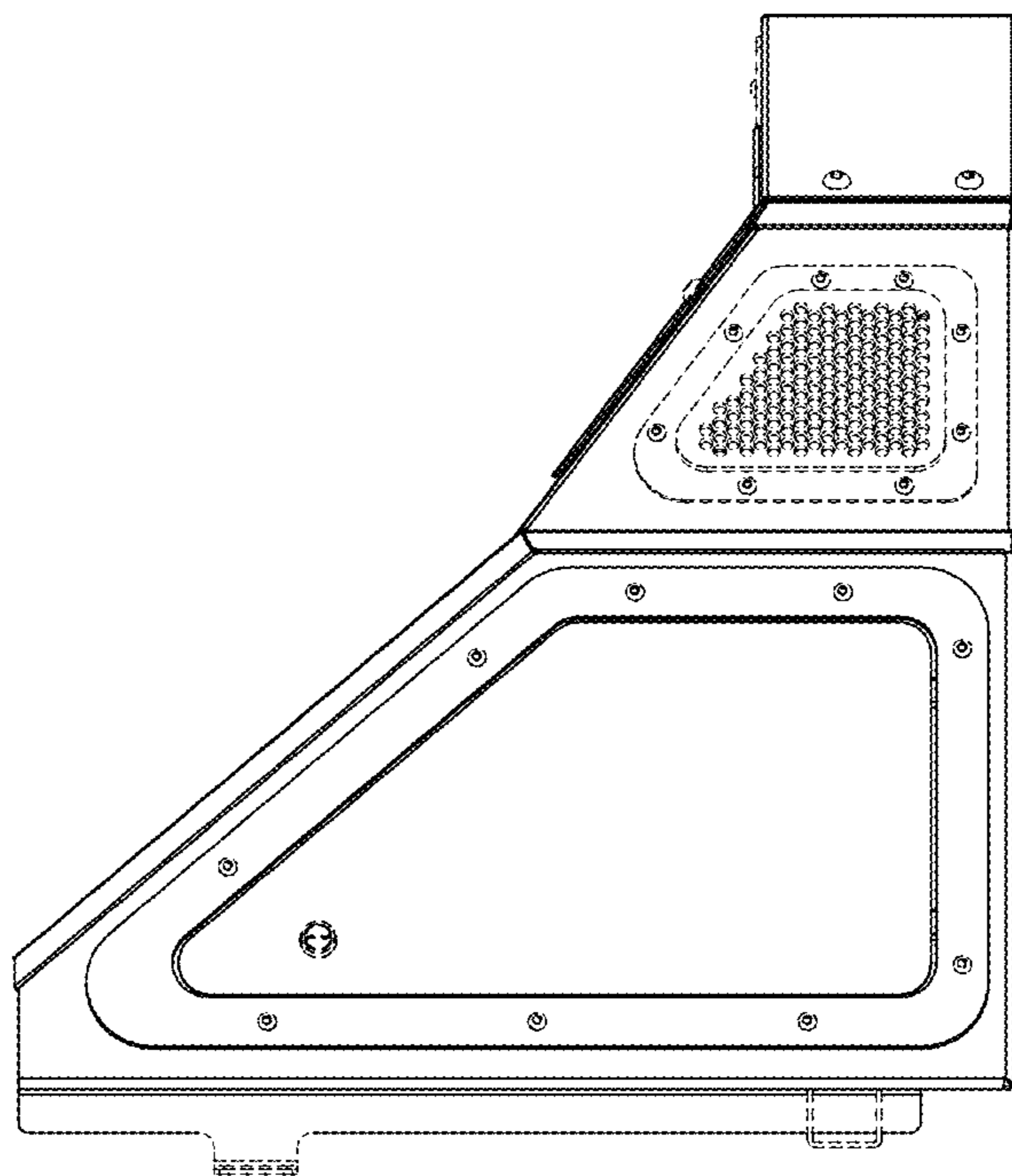

FIG - 13

FIG - 14





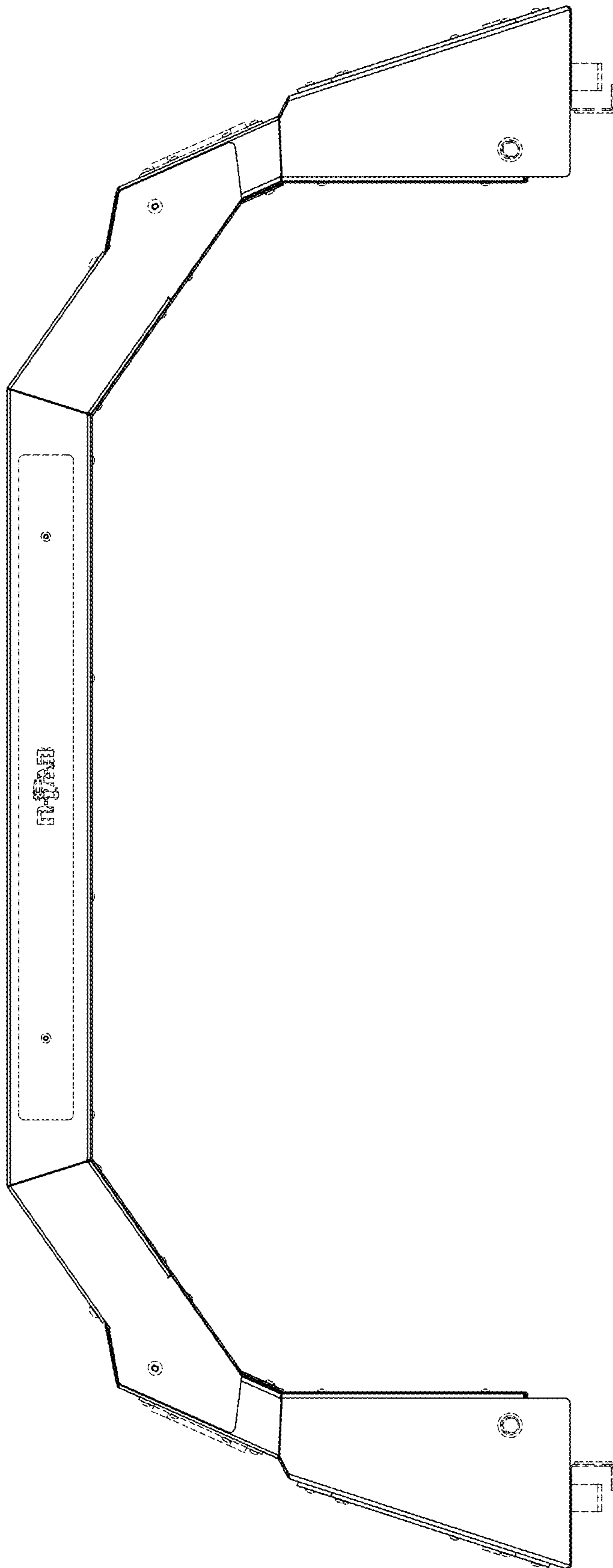

FIG - 15

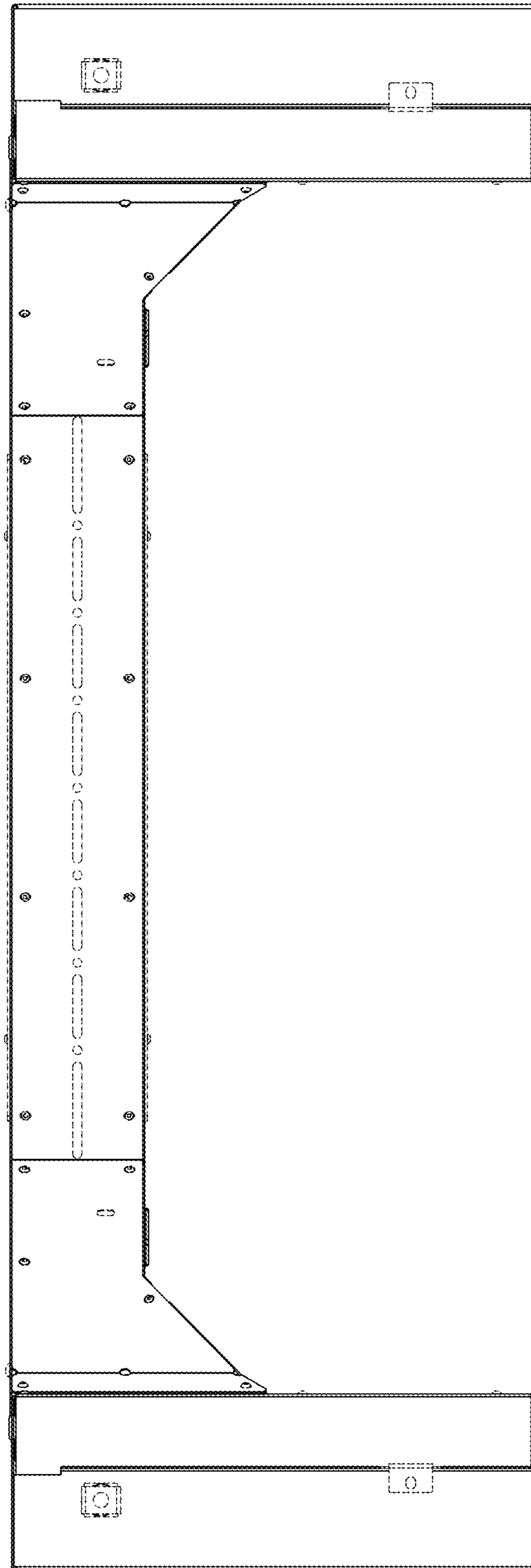

FIG - 16