



US0D1027784S

(12) **United States Design Patent**
Hubers et al.

(10) **Patent No.:** **US D1,027,784 S**

(45) **Date of Patent:** **** May 21, 2024**

(54) **VEHICLE WHEEL**

(71) Applicants: **Adam Hubers**, Clawson, MI (US);
Irina Zavatski, Rochester Hills, MI (US)

(72) Inventors: **Adam Hubers**, Clawson, MI (US);
Irina Zavatski, Rochester Hills, MI (US)

(73) Assignee: **FCA US LLC**, Auburn Hills, MI (US)

(**) Term: **15 Years**

(21) Appl. No.: **29/776,268**

(22) Filed: **Mar. 29, 2021**

(51) **LOC (14) Cl.** **12-16**

(52) **U.S. Cl.**
USPC **D12/209; D12/211**

(58) **Field of Classification Search**
USPC D12/204–213; D21/563
CPC B60B 7/00; B60B 7/02; B60B 7/04; B60B 7/01; B60B 7/06; B60B 3/02; B60B 3/04; B60B 3/06; B60B 3/10; B60B 1/00; B60B 1/08; B60B 1/10; B60B 1/12
See application file for complete search history.

(56) **References Cited**

U.S. PATENT DOCUMENTS

D438,163 S * 2/2001 Langerer D12/211
D569,323 S * 5/2008 Laengerer D12/211

D583,742 S * 12/2008 Juergens D12/211
D610,517 S * 2/2010 Leng D12/211
D622,199 S * 8/2010 Gallert D12/211
D733,632 S * 7/2015 Juergens D12/211
D789,268 S * 6/2017 Gallert D12/209
D819,538 S * 6/2018 Badstuebner D12/211
D828,264 S * 9/2018 Owens D12/209
D853,307 S * 7/2019 He D12/211
D928,681 S * 8/2021 Yeh D12/209
D933,571 S * 10/2021 Patel D12/211

* cited by examiner

Primary Examiner — Calvin E Vansant

(74) *Attorney, Agent, or Firm* — Jeremy J. Klobucar

(57) **CLAIM**

The ornamental design for a vehicle wheel, as shown and described.

DESCRIPTION

FIG. 1 is a right perspective view of a vehicle wheel showing our new design;
FIG. 2 is a left perspective view thereof; and,
FIG. 3 is a front view thereof.
It will be understood that the broken lines shown in the drawings illustrate portions of the vehicle wheel that form no part of the claimed design.

1 Claim, 3 Drawing Sheets

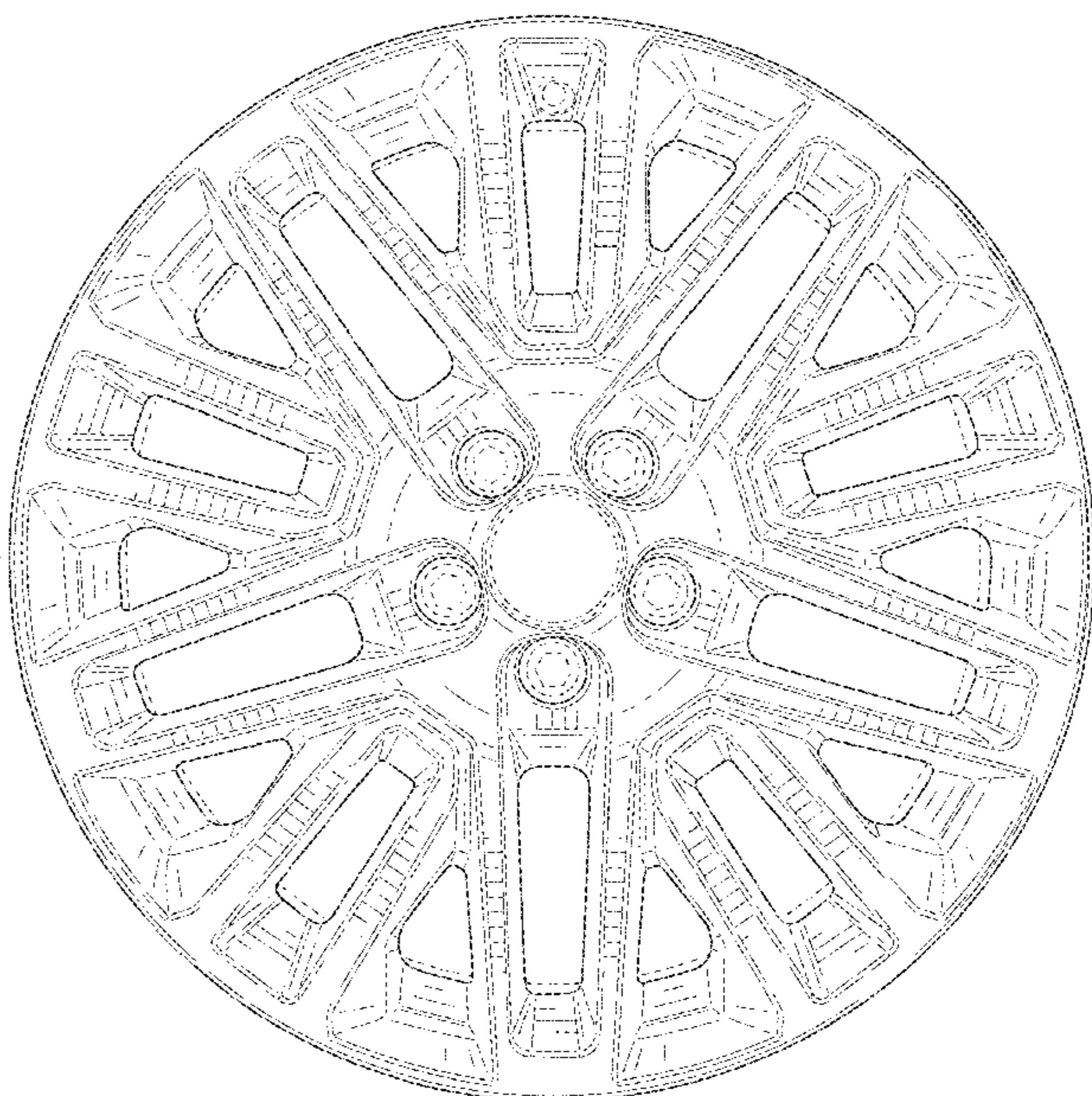
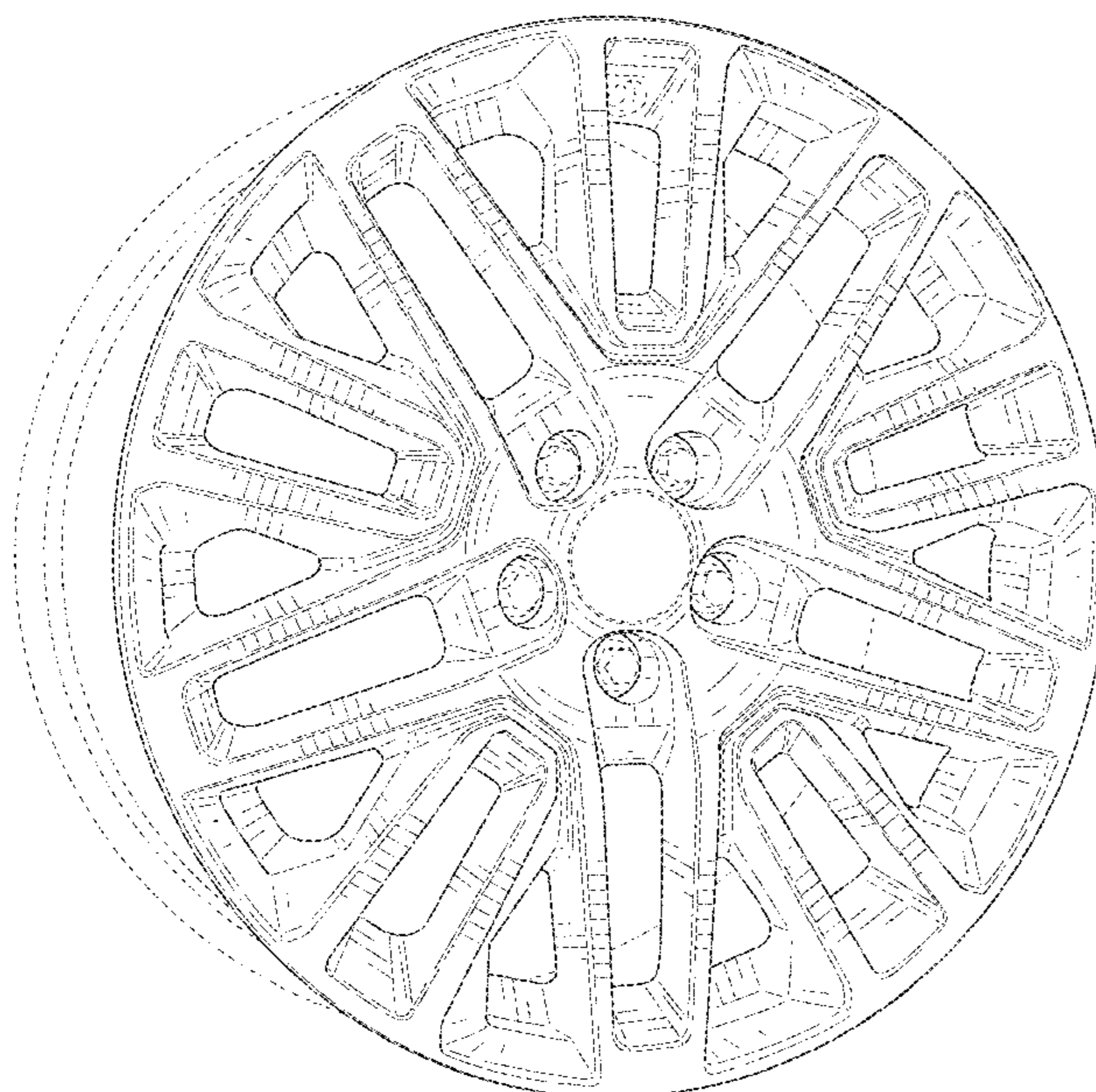

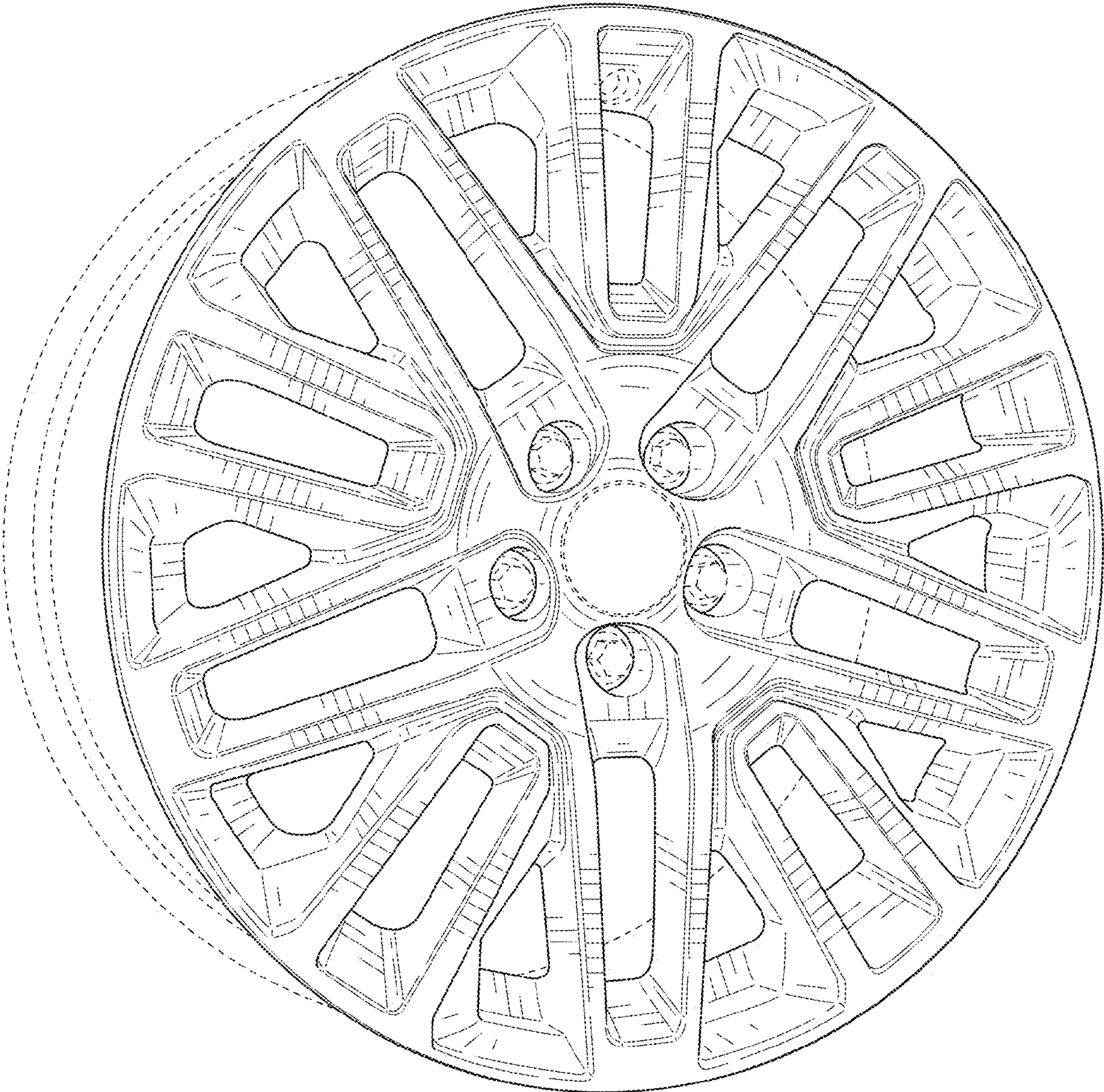

FIG. 1

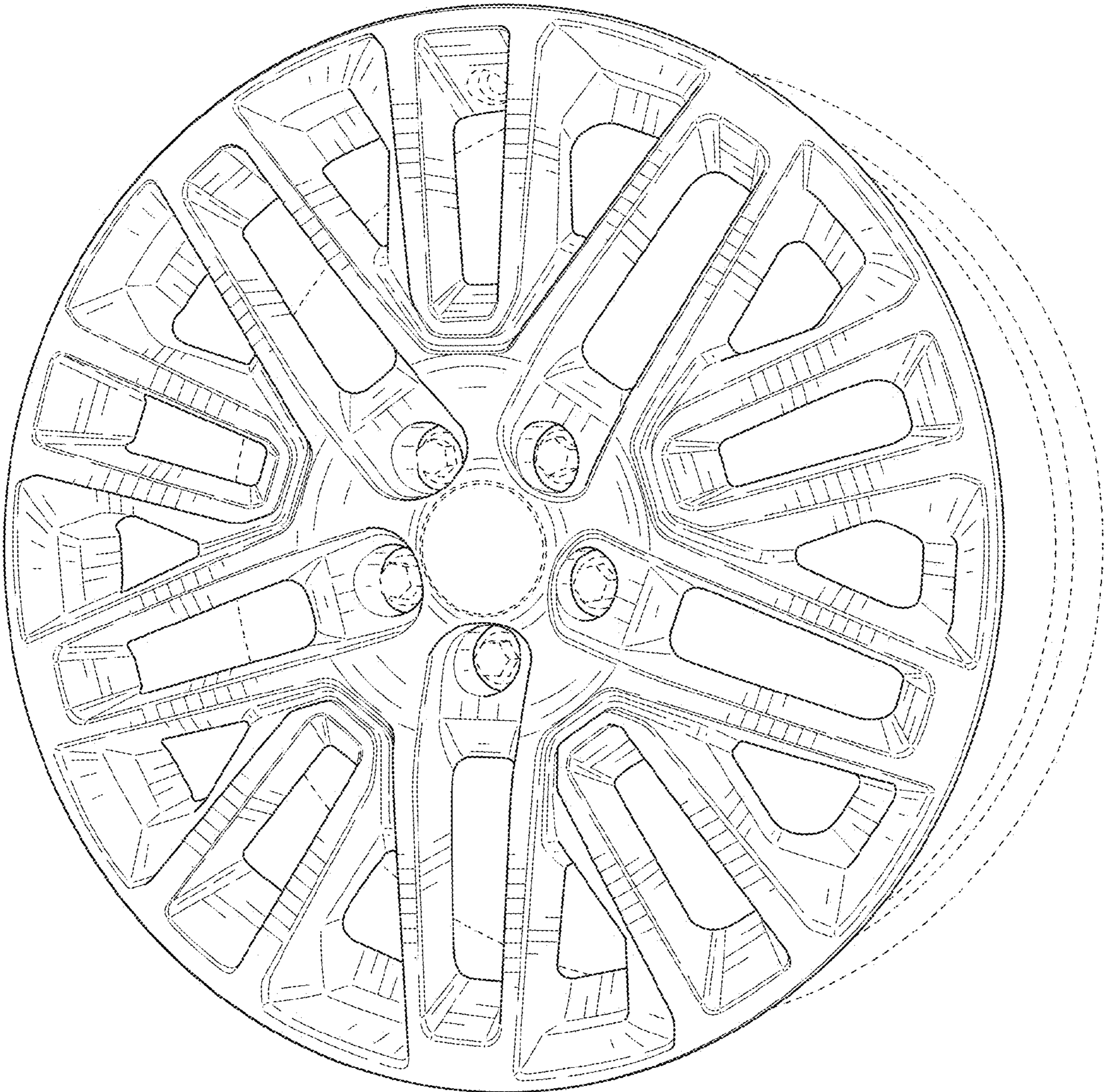

FIG. 2

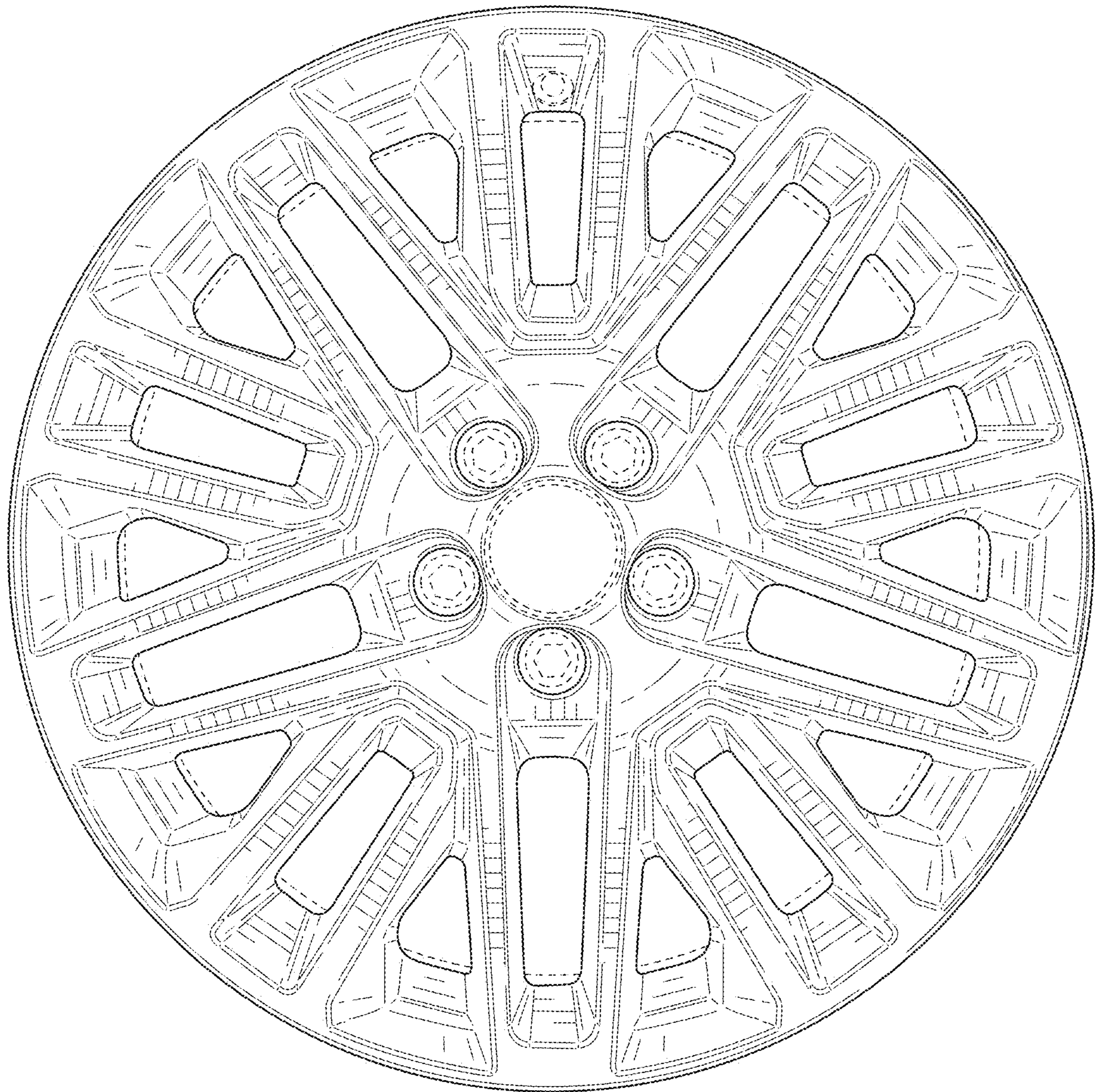

FIG. 3