



US0D1026602S

(12) **United States Design Patent**
Kukucka et al.

(10) **Patent No.:** **US D1,026,602 S**

(45) **Date of Patent:** **** May 14, 2024**

(54) **SELECTABLE TWIST TOOL**

(71) Applicant: **GRIP HOLDINGS LLC**, Brandon, FL (US)

(72) Inventors: **Paul Kukucka**, Brandon, FL (US);
Thomas Stefan Kukucka, Brandon, FL (US)

(73) Assignee: **GRIP HOLDINGS LLC**, Brandon, FL (US)

(**) Term: **15 Years**

(21) Appl. No.: **29/831,164**

(22) Filed: **Mar. 17, 2022**

(51) **LOC (14) Cl.** **08-05**

(52) **U.S. Cl.**
USPC **D8/14; D8/29**

(58) **Field of Classification Search**
USPC D8/14, 21, 29, 70
CPC B25B 13/06; B25B 13/065; B25B 13/56
See application file for complete search history.

(56) **References Cited**

U.S. PATENT DOCUMENTS

| | | | |
|---------------|---------|-----------------|-------------------------------|
| 1,798,944 A | 3/1931 | Jackman | |
| 2,969,250 A | 1/1961 | Kull | |
| 3,161,090 A * | 12/1964 | McLellan | B25B 27/18 81/53.2 |
| 3,405,377 A | 10/1968 | Pierce | |
| 3,495,485 A | 2/1970 | Knudsen et al. | |
| 3,902,384 A | 9/1975 | Ehrler | |
| 3,908,489 A | 9/1975 | Yamamoto et al. | |
| 3,996,819 A * | 12/1976 | King | B25B 13/065 81/124.6 |
| 4,074,597 A | 2/1978 | Jansson | |
| 4,536,115 A | 8/1985 | Helderman | |
| 4,598,616 A | 7/1986 | Colvin | |
| 4,607,547 A | 8/1986 | Martus | |
| 4,893,530 A | 1/1990 | Warheit | |

| | | |
|-------------|--------|----------------|
| 4,927,020 A | 5/1990 | Randy |
| 4,930,378 A | 6/1990 | Colvin |
| 5,019,080 A | 5/1991 | Hemer |
| 5,219,392 A | 6/1993 | Ruzicka et al. |
| 5,228,570 A | 7/1993 | Robinson |

(Continued)

FOREIGN PATENT DOCUMENTS

| | | |
|----|-----------|--------|
| AU | 201612229 | 4/2016 |
| AU | 201612720 | 6/2016 |

(Continued)

Primary Examiner — Philip S Hyder

(57) **CLAIM**

The ornamental design for a selectable twist tool, as shown and described.

DESCRIPTION

FIG. 1 is a top-front perspective view of a selectable twist tool showing our new design;
 FIG. 2 is a top-rear perspective view thereof;
 FIG. 3 is a front elevational view thereof;
 FIG. 4 is a rear elevational view thereof;
 FIG. 5 is a right-side elevational view thereof;
 FIG. 6 is a left-side elevational view thereof;
 FIG. 7 is a cross-sectional view taken along line 7-7 in FIG. 6;
 FIG. 8 is a top plan view thereof;
 FIG. 9 is a bottom plan view thereof; and,
 FIG. 10 is a cross-sectional view taken along line 10-10 in FIG. 9.

The broken lines showing the tool body in FIG. 1-10 are included for the purpose of showing environmental structure and form no part of the claimed design. The selectable twist tool is shown with a symbolic break in its length in FIGS. 1-2 and 5-10. The appearance of any portion of the article between the break lines forms no part of the claimed design.

1 Claim, 10 Drawing Sheets

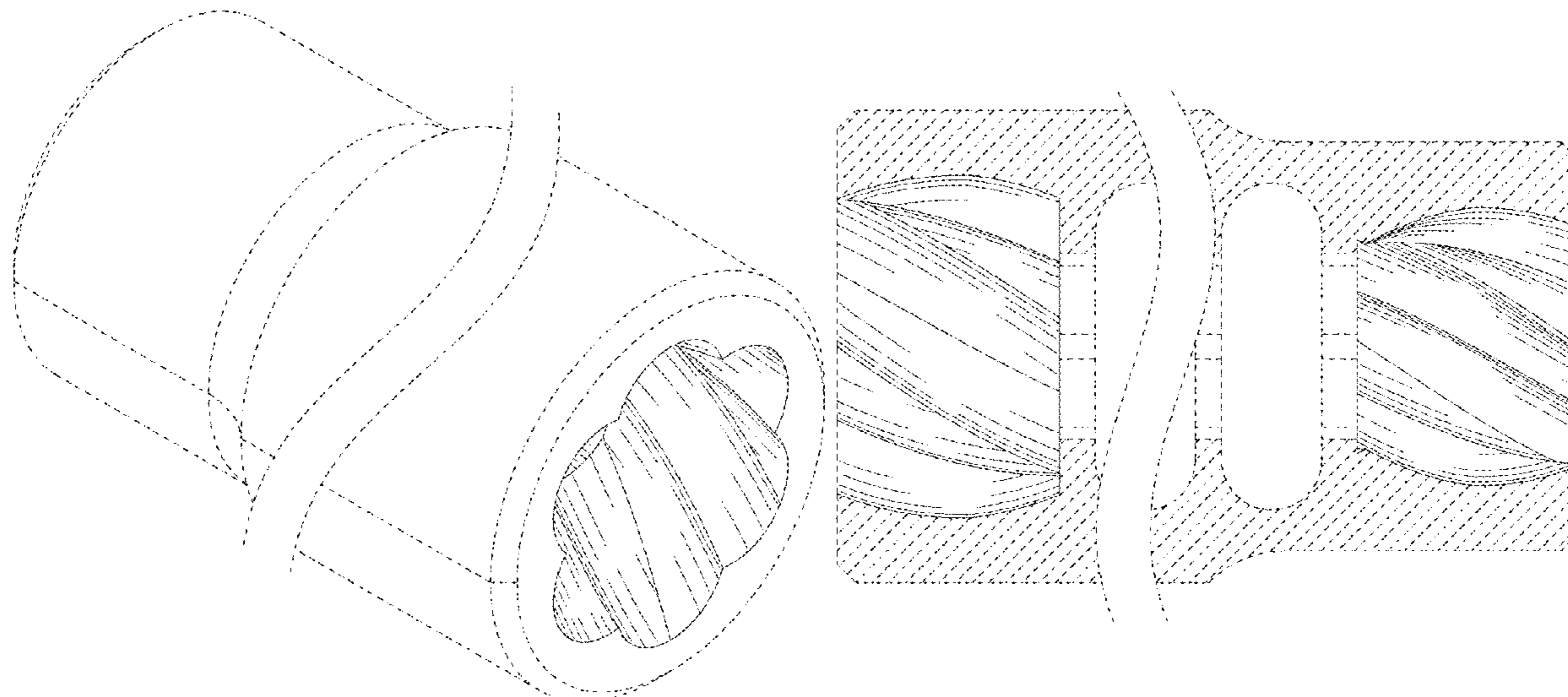

(56)

References Cited

U.S. PATENT DOCUMENTS

| | | | | | |
|----------------|---------|---|-------------------|---------|---|
| 5,251,521 A | 10/1993 | Burda et al. | D892,578 S | 8/2020 | Kukucka et al. |
| 5,398,823 A | 3/1995 | Anders | 10,780,556 B2 | 9/2020 | Kukucka et al. |
| 5,481,948 A | 1/1996 | Zerkovitz | 10,786,890 B2 | 9/2020 | Kukucka et al. |
| 5,501,342 A | 3/1996 | Geibel | D899,091 S | 10/2020 | Kukucka et al. |
| 5,519,929 A | 5/1996 | Bleckman | 10,828,766 B2 | 11/2020 | Kukucka et al. |
| 5,645,177 A | 7/1997 | Lin | D904,152 S | 12/2020 | Kukucka et al. |
| 5,669,516 A | 9/1997 | Horn | D906,781 S | 1/2021 | Kukucka et al. |
| 5,725,107 A | 3/1998 | Dembicks | 10,882,162 B2 | 1/2021 | Doroslovac et al. |
| 5,737,981 A | 4/1998 | Hildebrand | D909,842 S | 2/2021 | Kukucka et al. |
| 5,743,394 A | 4/1998 | Martin | D910,490 S | 2/2021 | Lim et al. |
| 5,782,148 A | 7/1998 | Kerkhoven | 10,919,133 B2 | 2/2021 | Kukucka et al. |
| 5,829,327 A | 11/1998 | Stanton | 10,967,488 B2 | 4/2021 | Kukucka et al. |
| 5,832,792 A | 11/1998 | Hsieh | 11,045,925 B2 | 6/2021 | Kukucka et al. |
| 6,009,778 A | 1/2000 | Hsieh | 11,154,969 B2 | 10/2021 | Kukucka et al. |
| 6,079,299 A | 6/2000 | Sundstroem | D937,060 S * | 11/2021 | Peng D8/29 |
| 6,092,279 A | 7/2000 | Shoup | D953,137 S * | 5/2022 | Fu D8/70 |
| 6,352,011 B1 | 3/2002 | Fruhm | D953,138 S * | 5/2022 | Fu D8/70 |
| 6,431,373 B1 | 8/2002 | Blick | D966,849 S * | 10/2022 | Peng D8/29 |
| 6,575,057 B1 | 6/2003 | Ploeger | D992,387 S * | 7/2023 | McKenzie B25B 27/18 |
| 6,598,498 B1 * | 7/2003 | Pigford B25B 13/065 81/53.2 | 2003/0209111 A1 | 11/2003 | Huang |
| 6,626,067 B1 | 9/2003 | Iwinski | 2004/0256263 A1 | 12/2004 | Shih |
| 6,698,316 B1 | 3/2004 | Wright | 2005/0098459 A1 | 5/2005 | Gorman |
| 6,729,208 B1 * | 5/2004 | Chrzanowski B25B 27/18 81/53.2 | 2005/0103664 A1 | 5/2005 | Shih |
| 6,755,098 B2 | 6/2004 | Huang | 2005/0183548 A1 * | 8/2005 | Horobec B25B 13/065 81/53.2 |
| 6,761,089 B2 | 7/2004 | Bergamo | 2005/0194330 A1 | 9/2005 | Ziske |
| 6,857,340 B2 | 2/2005 | Wagner | 2005/0257357 A1 | 11/2005 | Huang |
| 6,951,156 B2 | 10/2005 | Garg | 2005/0274233 A1 | 12/2005 | Lin |
| 7,000,501 B1 | 2/2006 | Chen | 2006/0117917 A1 * | 6/2006 | Lin B25B 27/18 81/125 |
| D524,615 S | 7/2006 | Albertson | 2006/0130618 A1 | 6/2006 | Hsieh |
| 7,137,514 B1 | 11/2006 | Nickipuck | 2006/0156869 A1 | 7/2006 | Hsieh |
| 7,225,710 B2 | 6/2007 | Pacheco | 2006/0266168 A1 | 11/2006 | Pacheco |
| 7,331,260 B2 | 2/2008 | Cheng | 2007/0261519 A1 | 11/2007 | Cheng |
| 7,434,494 B1 | 10/2008 | Snider | 2008/0235930 A1 | 10/2008 | English |
| 7,717,278 B2 | 1/2010 | Kao | 2009/0007732 A1 | 1/2009 | Hsieh |
| D614,931 S | 5/2010 | Su | 2009/0100971 A1 * | 4/2009 | Swanson B25B 27/18 81/53.2 |
| 7,788,994 B2 | 9/2010 | Wright et al. | 2009/0120885 A1 | 5/2009 | Kao |
| 7,841,480 B2 | 11/2010 | Hsieh | 2009/0220321 A1 | 9/2009 | Sakamura |
| 7,913,593 B2 | 3/2011 | Dahar et al. | 2010/0065520 A1 | 3/2010 | Hsieh |
| D649,848 S * | 12/2011 | Wegerich D8/25 | 2011/0056339 A1 | 3/2011 | Su |
| 8,166,851 B2 | 5/2012 | Pchola | 2011/0303052 A1 | 12/2011 | Chen |
| 8,302,255 B2 | 11/2012 | Lin | 2012/0060656 A1 | 3/2012 | Chang |
| 8,336,709 B1 | 12/2012 | Geibel | 2012/0132039 A1 | 5/2012 | Su |
| 9,132,533 B2 | 9/2015 | Lesche et al. | 2012/0210826 A1 * | 8/2012 | Stawarski B25B 27/18 81/53.2 |
| 9,186,782 B2 * | 11/2015 | Banks B25B 13/065 | 2012/0285298 A1 * | 11/2012 | Richardson B25B 13/06 81/124.6 |
| D745,814 S | 12/2015 | Hsieh | 2013/0047798 A1 | 2/2013 | Huang |
| D776,505 S | 1/2017 | Doroslovac | 2014/0260832 A1 | 9/2014 | Hsiao |
| 9,555,523 B2 * | 1/2017 | Richardson B25B 13/06 | 2014/0311302 A1 | 10/2014 | Taguchi et al. |
| D784,106 S | 4/2017 | Doroslovac | 2014/0331826 A1 | 11/2014 | Campbell |
| 9,687,968 B2 | 6/2017 | Doroslovac et al. | 2014/0360321 A1 | 12/2014 | Steinweg et al. |
| D794,405 S | 8/2017 | Doroslovac et al. | 2015/0135910 A1 | 5/2015 | Eggert et al. |
| 9,718,170 B2 | 8/2017 | Eggert et al. | 2015/0266169 A1 | 9/2015 | Campbell, II |
| D798,682 S | 10/2017 | Doroslovac et al. | 2015/0314429 A1 * | 11/2015 | Doroslovac B25B 13/065 81/441 |
| 9,873,195 B1 | 1/2018 | Buxton | 2015/0321332 A1 | 11/2015 | Lee |
| 9,878,441 B1 | 1/2018 | Kao | 2016/0067853 A1 | 3/2016 | Neto |
| D829,069 S | 9/2018 | Doroslovac et al. | 2016/0136792 A1 | 5/2016 | Harp |
| 10,081,094 B2 | 9/2018 | Doroslovac et al. | 2016/0223005 A1 | 8/2016 | Rathmann |
| 10,328,554 B2 | 6/2019 | Todd | 2016/0271764 A1 | 9/2016 | Huang |
| D854,898 S * | 7/2019 | Hyma D8/29 | 2016/0339564 A1 | 11/2016 | Chen |
| D859,944 S | 9/2019 | Kukucka et al. | 2017/0028538 A1 | 2/2017 | Lourenco et al. |
| D859,945 S | 9/2019 | Kukucka et al. | 2017/0246733 A1 | 8/2017 | Shehab |
| D859,946 S | 9/2019 | Kukucka et al. | 2017/0252905 A1 | 9/2017 | Doroslovac |
| D859,947 S | 9/2019 | Kukucka et al. | 2017/0282337 A1 | 10/2017 | Johnson et al. |
| D867,841 S | 11/2019 | Kukucka et al. | 2017/0312839 A1 | 11/2017 | Moss et al. |
| D868,553 S | 12/2019 | Kukucka et al. | 2017/0312897 A1 | 11/2017 | Doroslovac et al. |
| 10,493,519 B2 | 12/2019 | Ross | 2018/0003241 A1 | 1/2018 | Goss |
| D879,577 S | 3/2020 | Kukucka et al. | 2018/0141192 A1 | 5/2018 | Chang |
| D880,968 S | 4/2020 | Kukucka et al. | 2018/0354022 A1 | 12/2018 | Ross et al. |
| D880,977 S | 4/2020 | Kukucka et al. | 2018/0354102 A1 | 12/2018 | Kukucka et al. |
| D885,149 S | 5/2020 | Kukucka et al. | 2019/0001469 A1 | 1/2019 | Cho et al. |
| D887,233 S * | 6/2020 | Kukucka D8/29 | 2019/0015961 A1 | 1/2019 | Kukucka et al. |
| D887,711 S | 6/2020 | Kukucka et al. | 2019/0152033 A1 | 5/2019 | Kukucka et al. |
| D889,224 S | 7/2020 | Kukucka et al. | 2019/0176310 A1 * | 6/2019 | McKenzie et al. ... B25B 13/065 |
| D889,257 S | 7/2020 | Kukucka et al. | | | |

(56)

References Cited

U.S. PATENT DOCUMENTS

2019/0217449 A1 7/2019 Lee
 2019/0283233 A1 9/2019 Kukucka et al.
 2019/0337131 A1 11/2019 Kukucka et al.
 2019/0375077 A1 12/2019 Kukucka et al.
 2020/0070321 A1 3/2020 Schulz
 2020/0078908 A1 3/2020 Wu et al.
 2020/0269398 A1 8/2020 Donovan
 2020/0298380 A1 9/2020 Doroslovac et al.
 2020/0376648 A1 12/2020 Kukucka et al.
 2020/0391360 A1 12/2020 Kukucka et al.
 2021/0039245 A1 2/2021 Kukucka et al.

FOREIGN PATENT DOCUMENTS

AU 201612721 6/2016
 CA 2564093 A1 4/2007
 CA 168071 12/2016
 CA 2898480 A1 7/2017
 CN 2767068 Y 3/2006
 CN 3630254 6/2006
 CN 201046555 Y 4/2008
 CN 102395447 3/2012
 CN 102554833 A 7/2012
 CN 103639950 A 3/2014
 CN 303924849 11/2016
 CN 303956827 12/2016
 CN 303984883 12/2016
 CN 207548606 U 6/2018
 DE 3911409 A1 10/1990
 DE 9403220 U1 4/1994
 DE 4321325 A1 1/1995
 DE 29613327 U1 9/1996
 DE 10321284 A1 12/2004
 DE 202010006146 U1 7/2010
 DE 202012103034 11/2012
 DE 102012104298 A1 11/2013
 DE 102013021238 A1 6/2015
 EP 0930132 A2 7/1999
 EP 0930132 A3 11/2000
 EP 1371453 A2 12/2003
 EP 1731774 A1 12/2006
 EP 1731774 A1 12/2006
 EP 0930132 B1 4/2007
 EP 2363245 A2 9/2011
 EP 2363245 A3 7/2015
 GB 906839 A 9/1962
 GB 1294764 A 11/1972
 GB 2366532 A 3/2002
 JP 2011143522 7/2011
 JP 2012157913 10/2011

JP 2015180835 A 7/2017
 KR 200149097 Y1 7/1999
 RU 2152870 C1 7/2000
 RU 2225786 C2 1/2001
 RU 45671 U1 5/2005
 RU 58510 U1 11/2006
 RU 2387533 C1 4/2010
 RU 116398 5/2012
 RU 180548 U1 6/2018
 SU 16616 A1 8/1930
 TW 201341127 A 10/2013
 WO 1994016862 A1 8/1994
 WO 1996010932 A1 4/1996
 WO 1996026870 A1 9/1996
 WO 1996027745 A1 9/1996
 WO 1997010926 A1 3/1997
 WO 1998012982 A1 4/1998
 WO 999032264 7/1999
 WO 1999032264 A1 7/1999
 WO 1999032264 A1 7/1999
 WO 2001066312 A1 9/2001
 WO 2004002687 A1 1/2004
 WO 2005070621 8/2005
 WO 2006023374 3/2006
 WO 2006130490 A1 12/2006
 WO 2010007402 A1 1/2010
 WO 2011109040 A1 9/2011
 WO 2013028875 A1 2/2013
 WO 2015082283 A1 6/2015
 WO 2015050942 A1 9/2015
 WO 2016051080 A1 4/2016
 WO DM/090809 4/2016
 WO DM/091188 5/2016
 WO DM/091189 5/2016
 WO 2016174615 A1 11/2016
 WO 2017178997 10/2017
 WO 2017187388 A1 11/2017
 WO 2018150360 A1 8/2018
 WO 2018172831 9/2018
 WO 2019012486 1/2019
 WO 2019167032 9/2019
 WO 2019175652 9/2019
 WO 2020039281 2/2020
 WO 2020039285 2/2020
 WO 2020058777 3/2020
 WO 2020152516 7/2020
 WO 2020208608 10/2020
 WO 2020225800 11/2020
 WO 2021001696 1/2021
 WO 2021019500 2/2021
 WO 2021033152 2/2021
 WO 2022047236 A1 3/2022

* cited by examiner

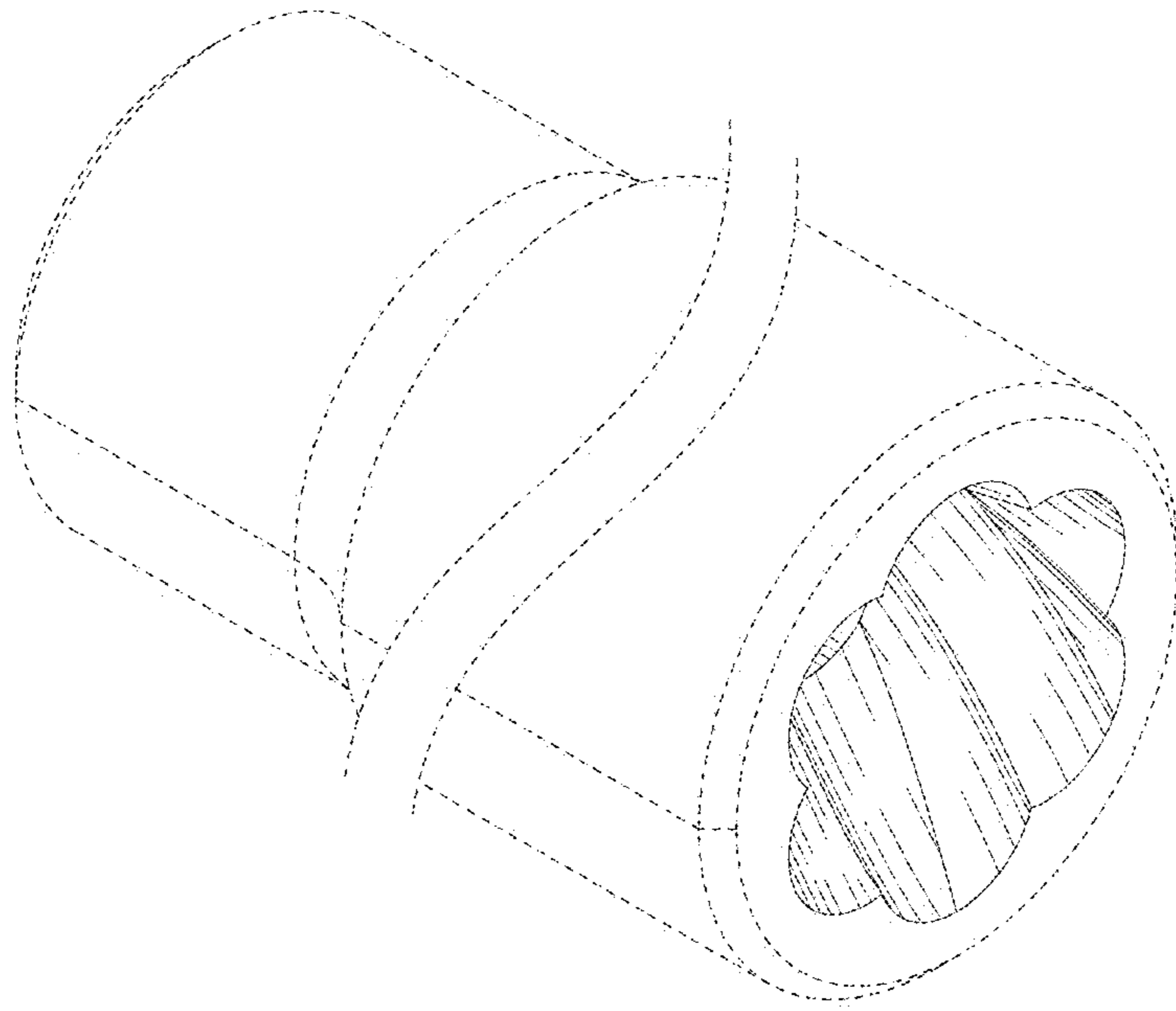

FIG. 1

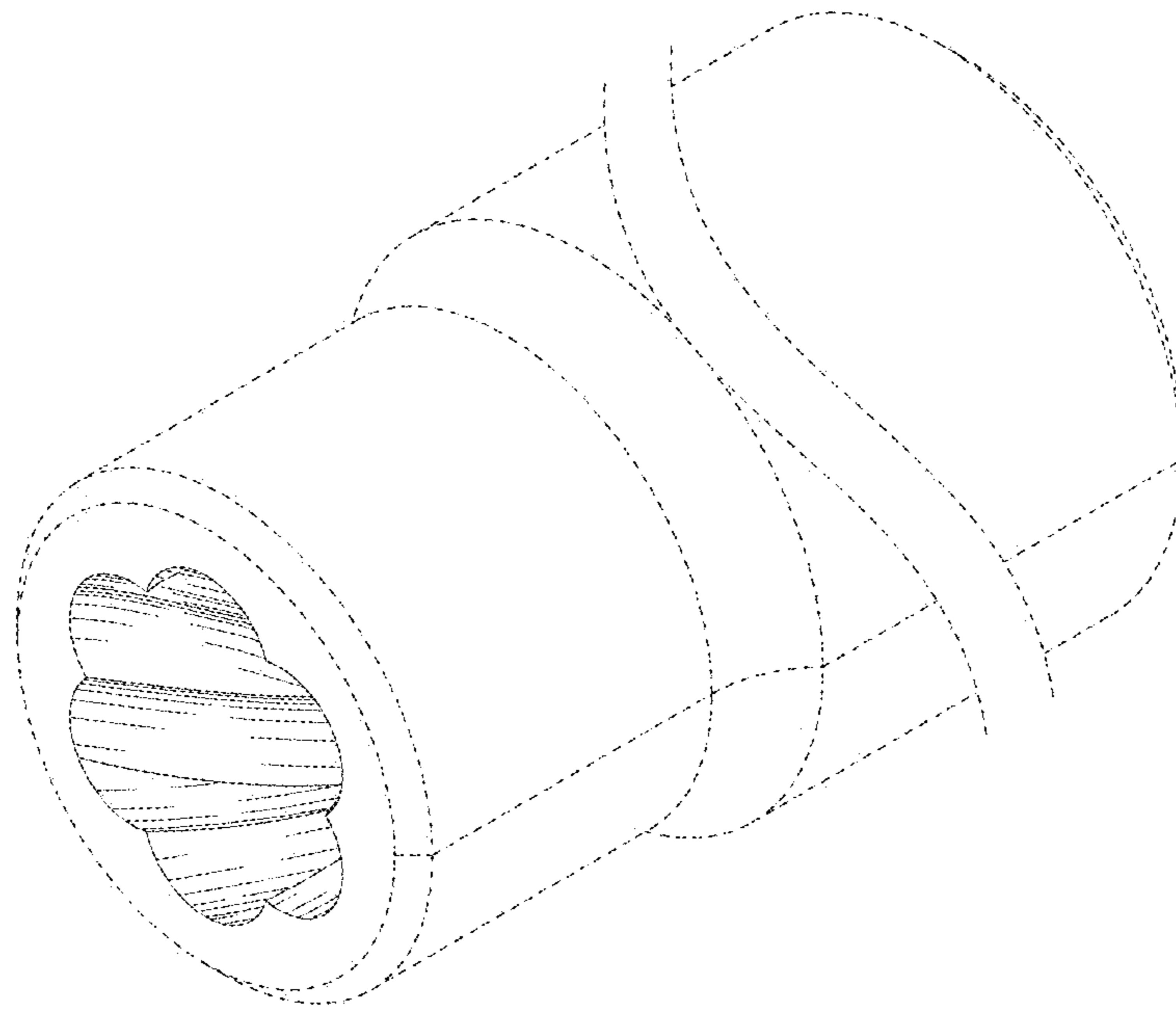

FIG. 2

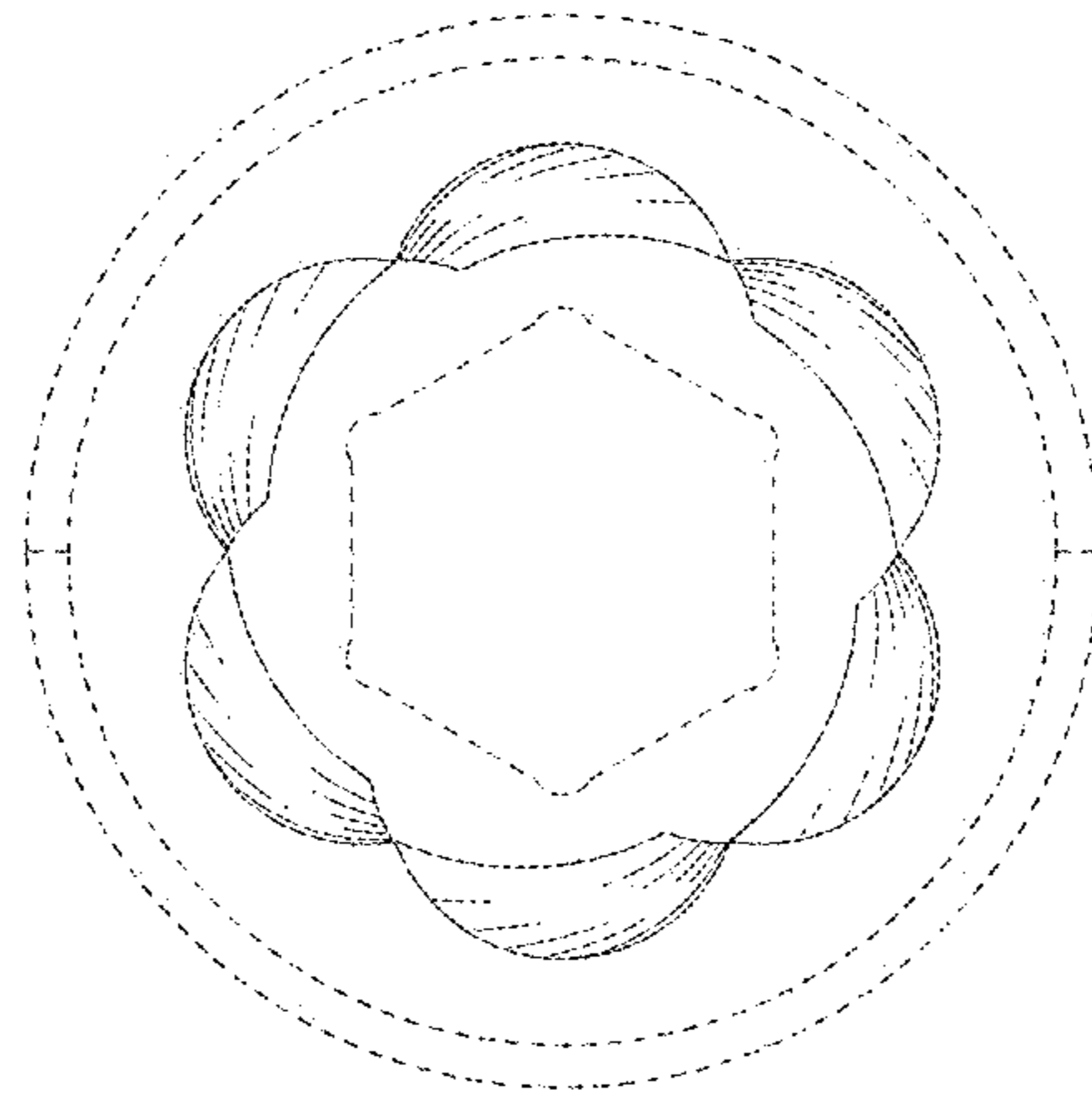

FIG. 3

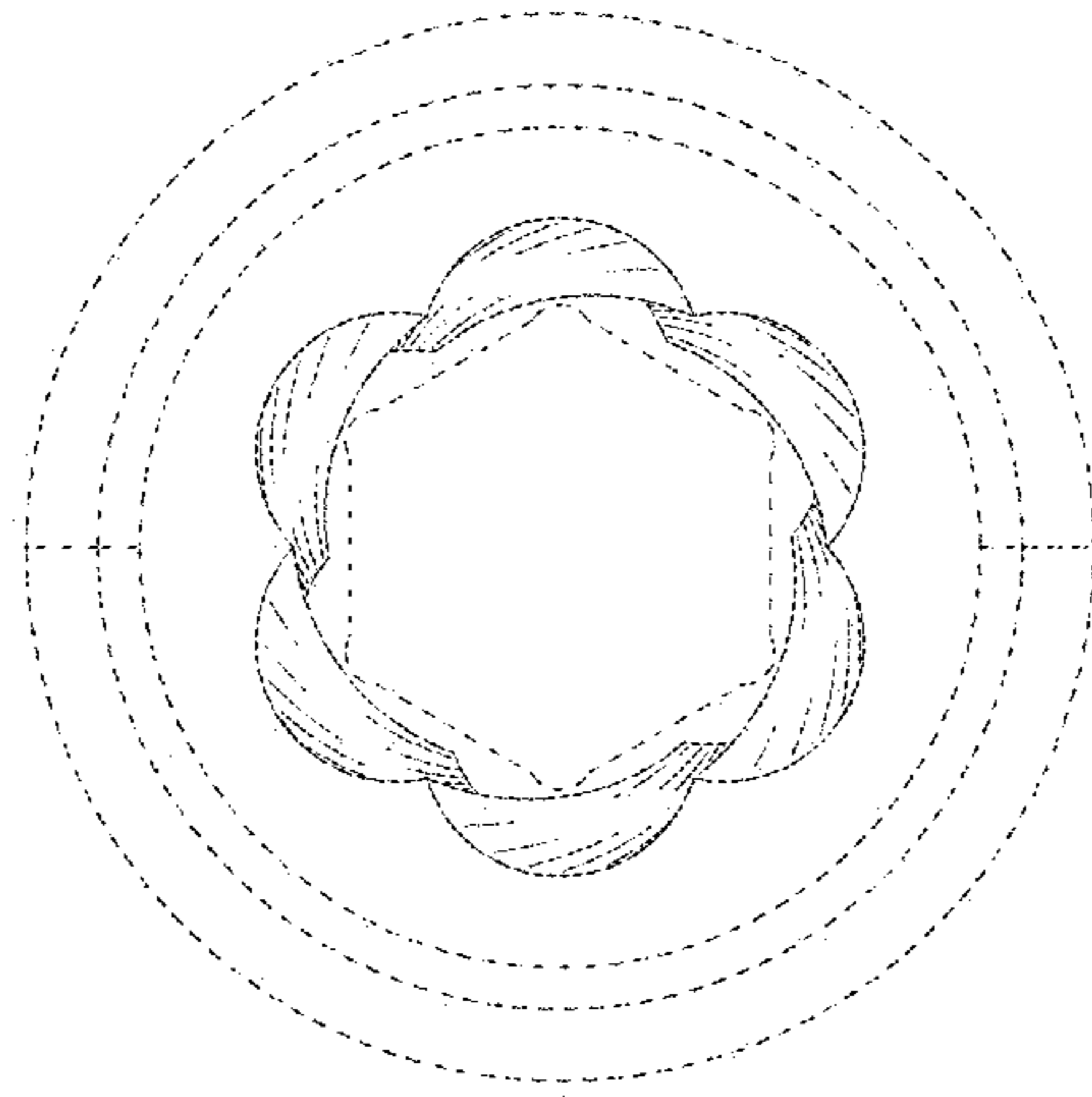

FIG. 4

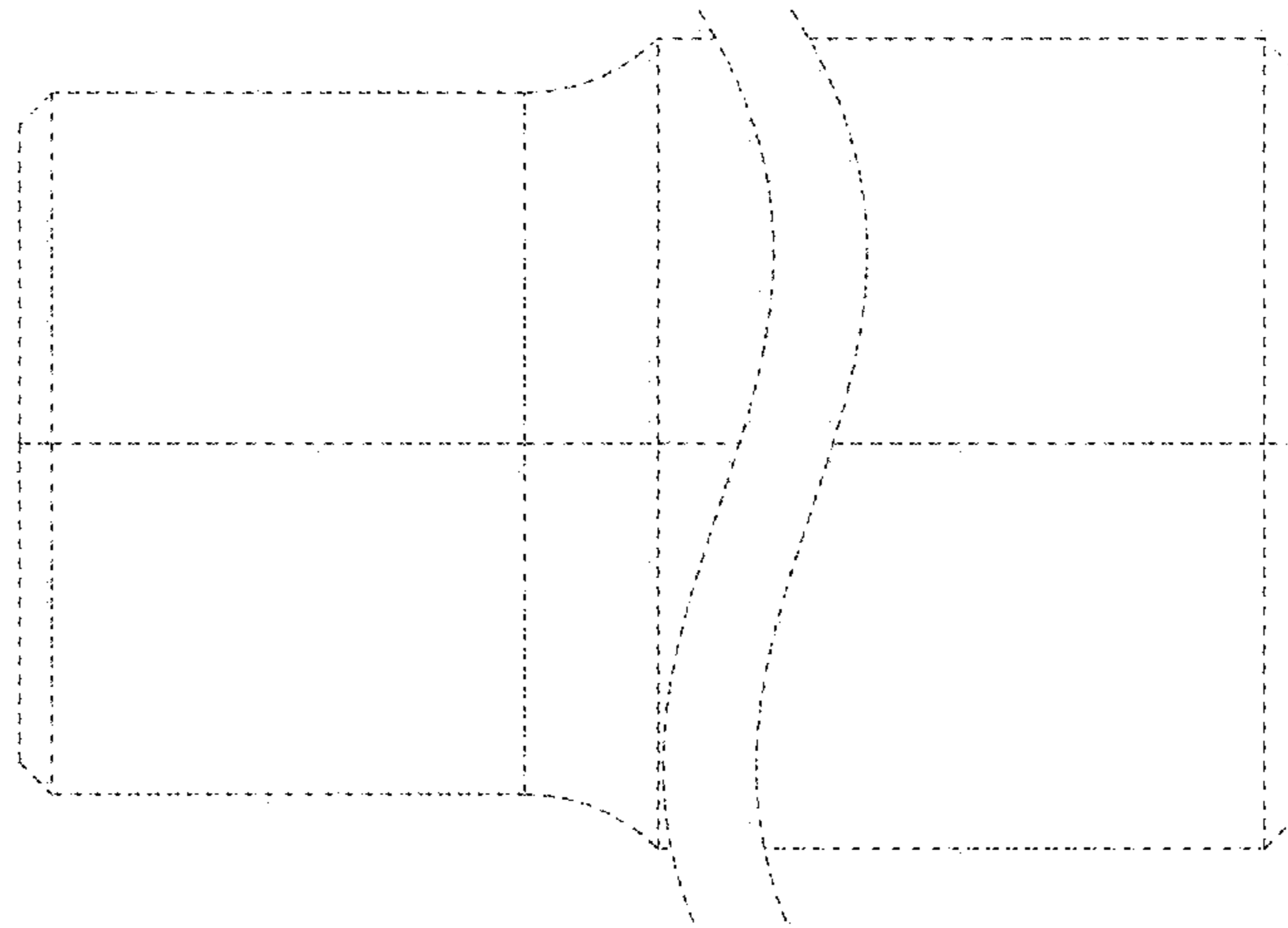

FIG. 5

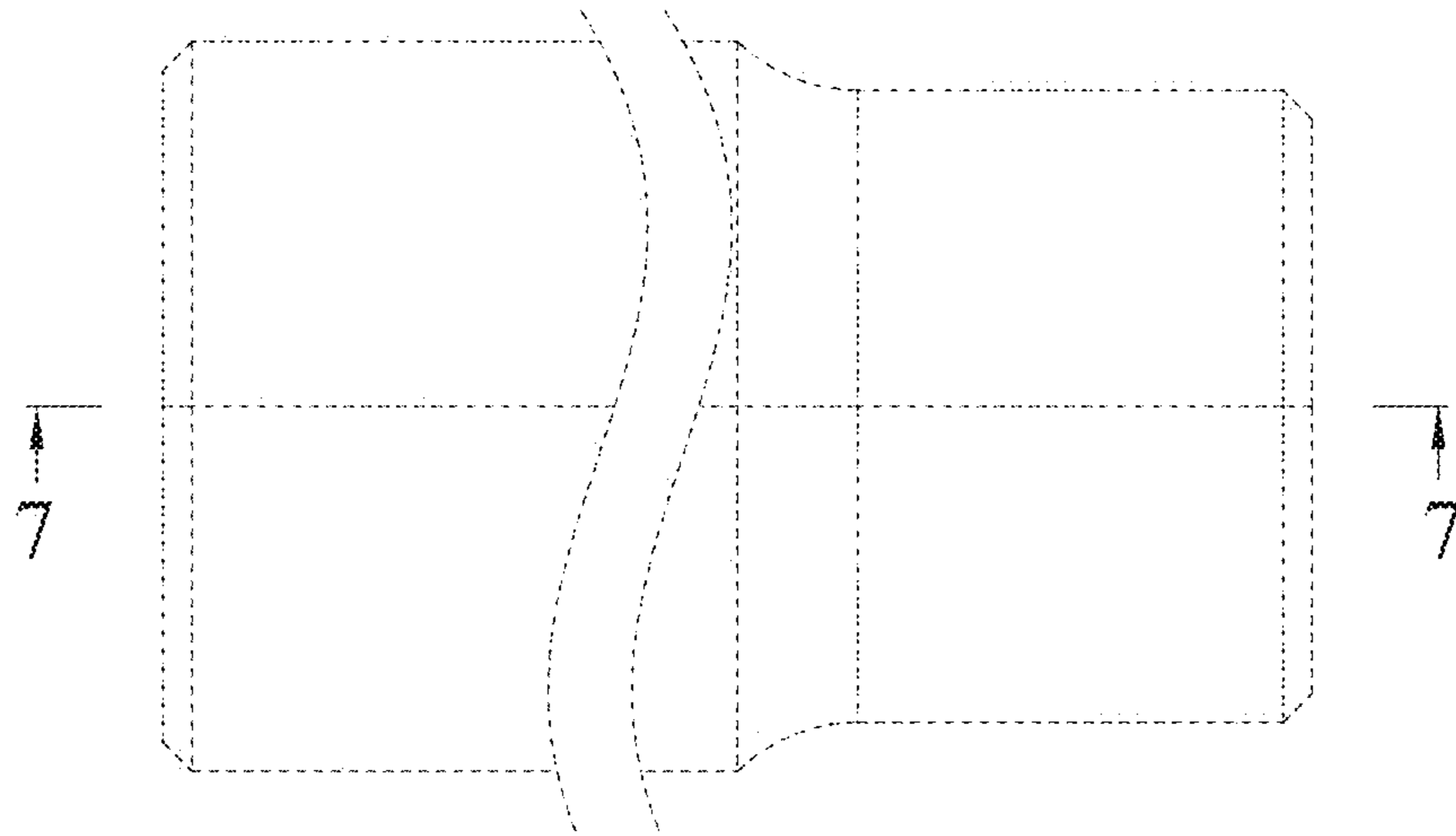

FIG. 6

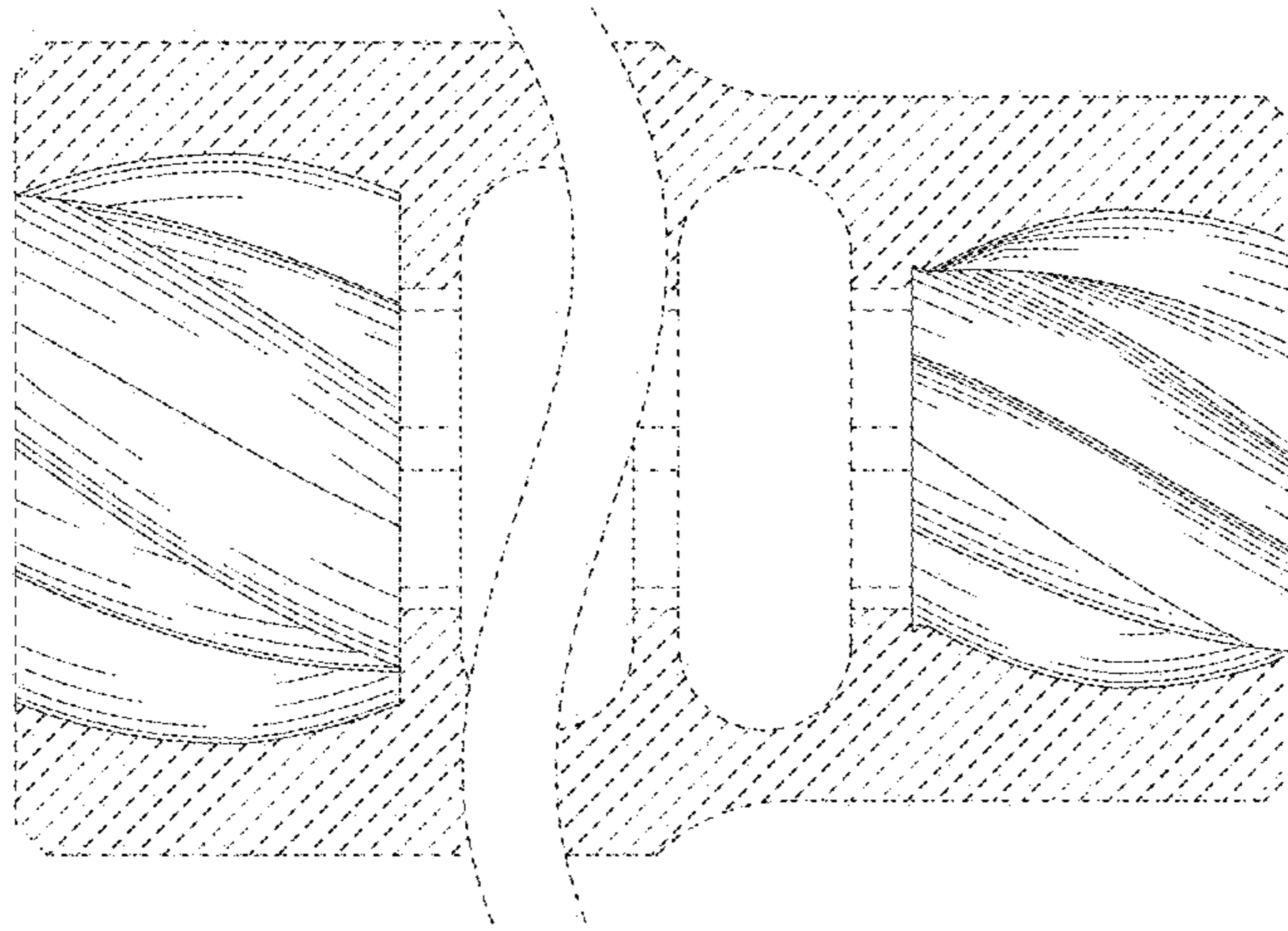

FIG. 7

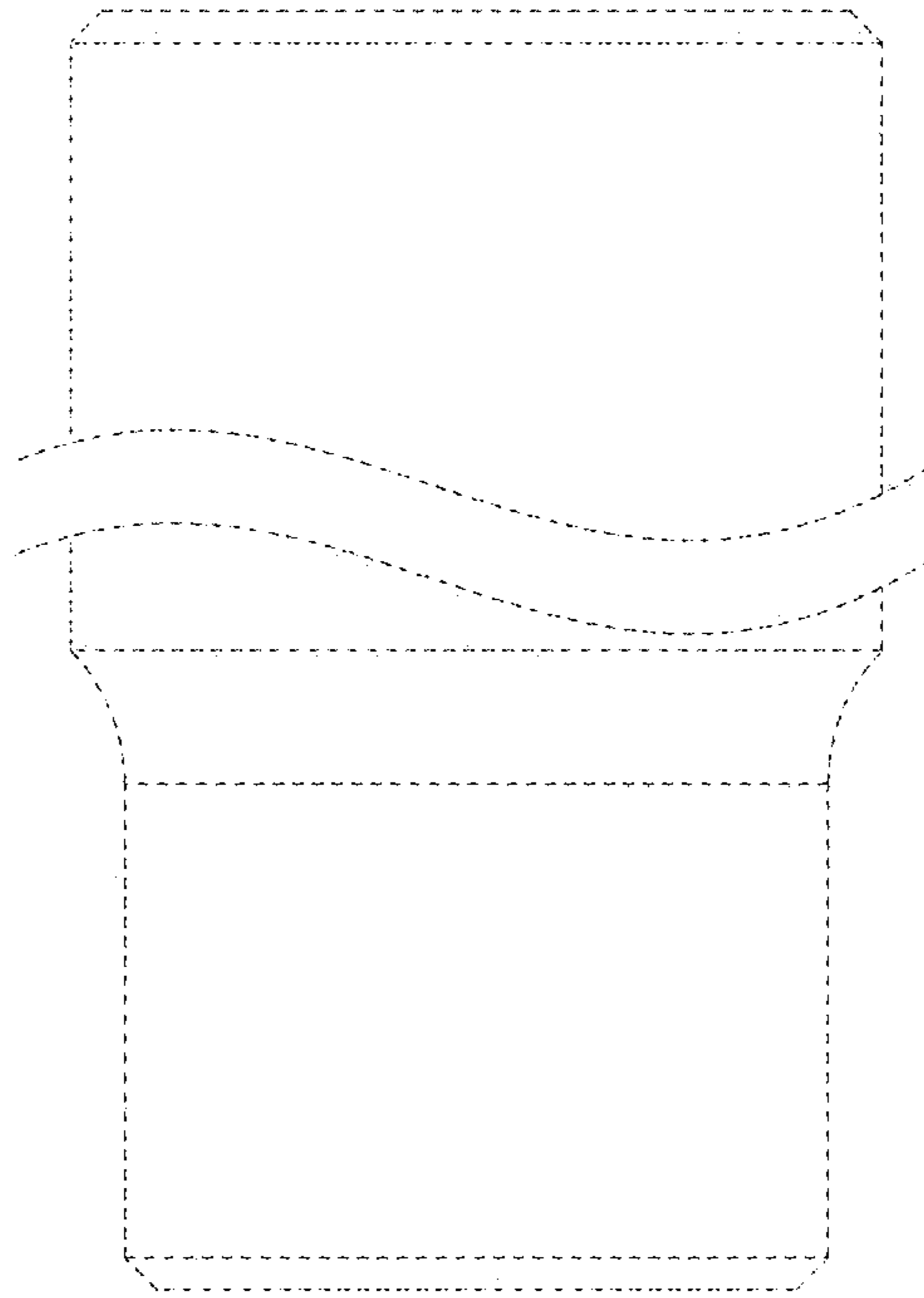

FIG. 8

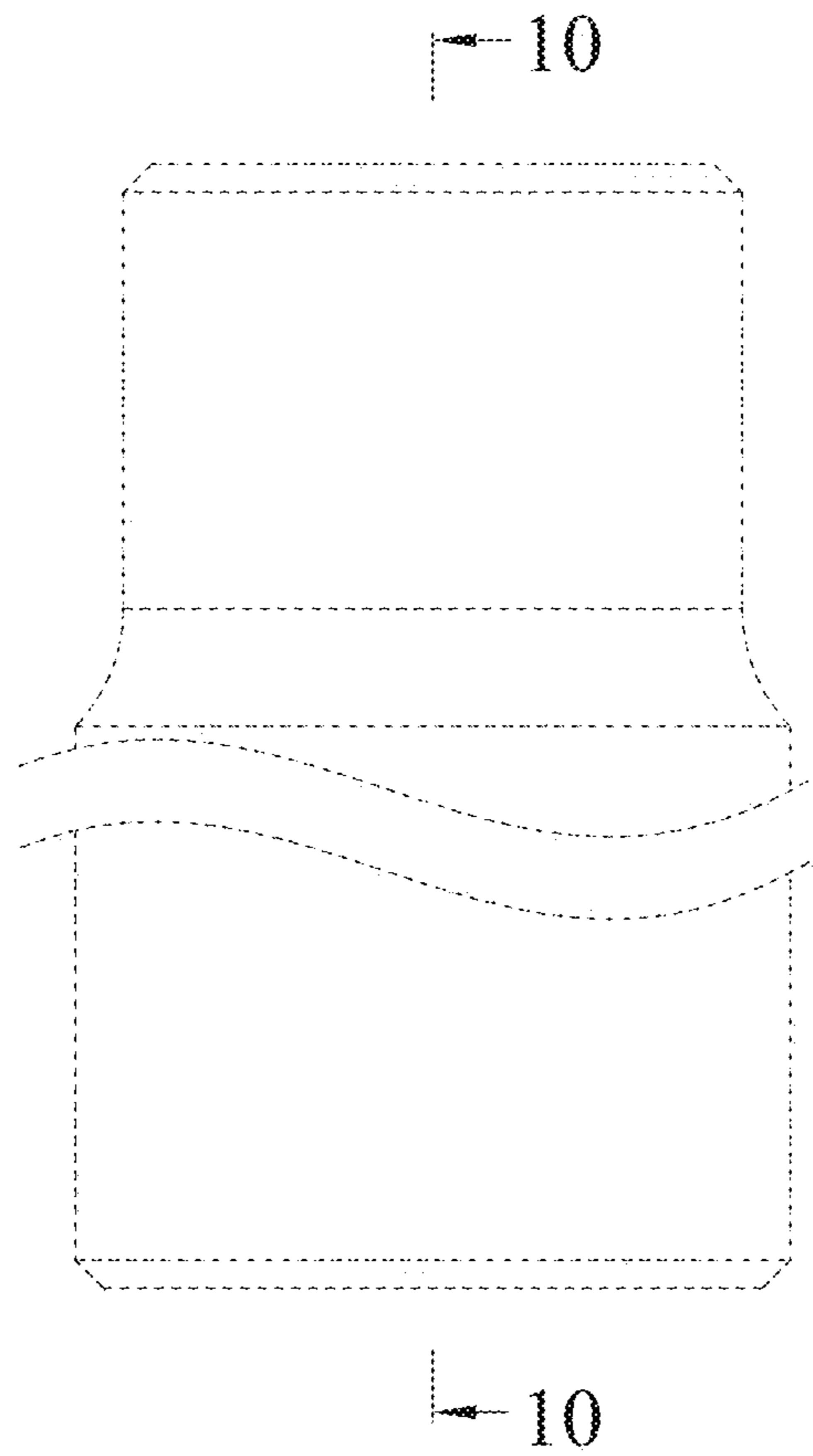

FIG. 9

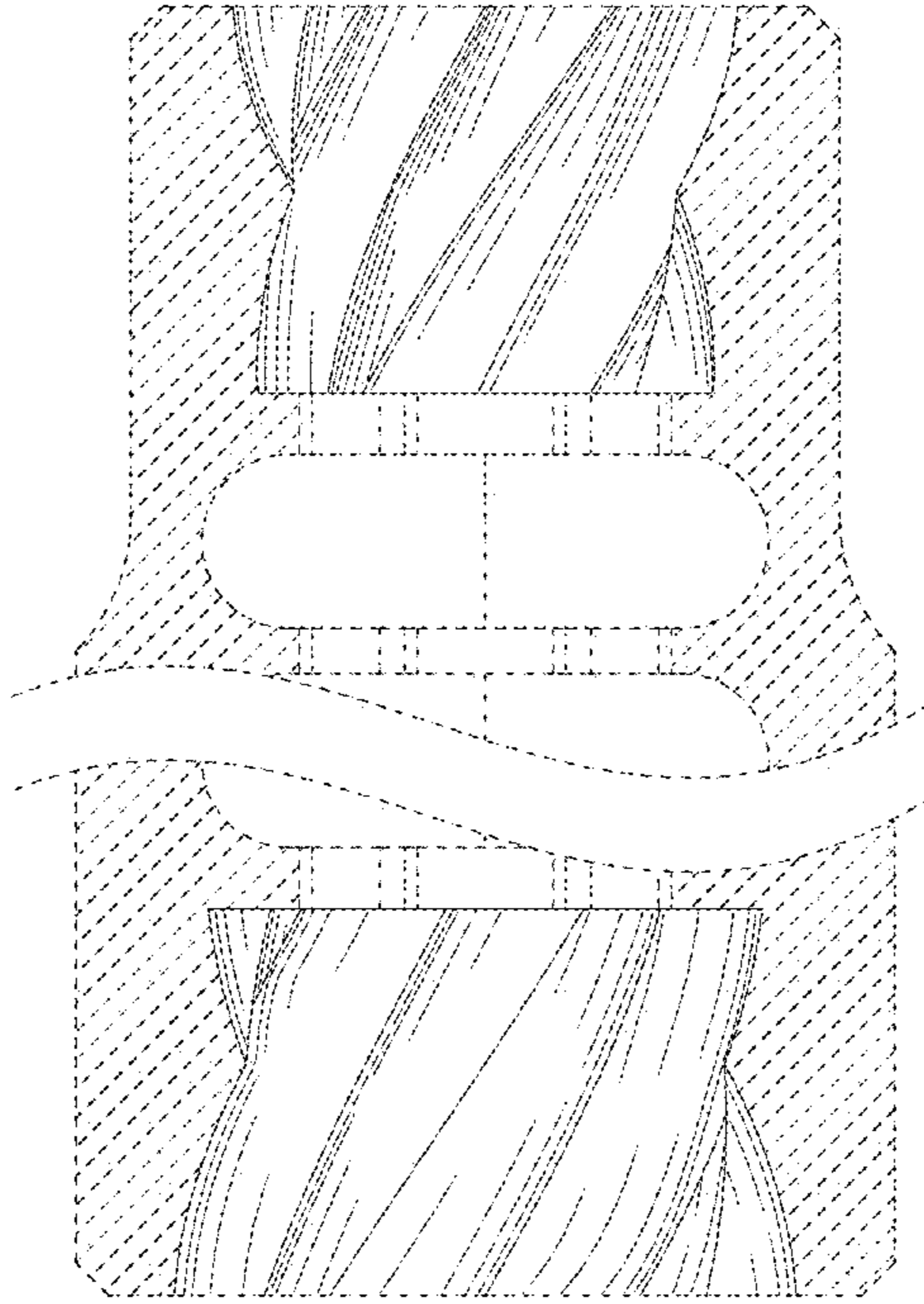

FIG. 10