



US0D1024963S

(12) **United States Design Patent** (10) **Patent No.:** **US D1,024,963 S**  
**Ochiai et al.** (45) **Date of Patent:** **\*\* Apr. 30, 2024**

(54) **MOTOR**  
(71) Applicant: **EBARA CORPORATION**, Tokyo (JP)  
(72) Inventors: **Akihiro Ochiai**, Tokyo (JP); **Kazuma Nishimura**, Tokyo (JP); **Yohei Oishi**, Tokyo (JP); **Takahide Ozawa**, Tokyo (JP); **Masayuki Nagai**, Tokyo (JP); **Shin Takahashi**, Tokyo (JP); **Yuhei Shinchi**, Tokyo (JP)  
(73) Assignee: **EBARA CORPORATION**, Tokyo (JP)  
(\*\*) Term: **15 Years**  
(21) Appl. No.: **29/865,747**  
(22) Filed: **Aug. 10, 2022**  
(30) **Foreign Application Priority Data**

Feb. 14, 2022 (JP) ..... 2022-002726 D  
(51) **LOC (14) Cl.** ..... **13-01**  
(52) **U.S. Cl.**  
USPC ..... **D13/112**  
(58) **Field of Classification Search**  
USPC ..... D13/112, 113, 114, 122, 184, 199;  
D15/1, 5, 148, 149  
CPC ..... H02K 5/06; H02K 5/225; H02K 11/33;  
H02K 9/14; H02K 7/1025; H02K  
7/20918; Y02T 10/72; B60K 7/0007  
See application file for complete search history.

(56) **References Cited**  
U.S. PATENT DOCUMENTS  
D207,401 S \* 4/1967 Andrews et al. .... D13/114  
D217,674 S \* 5/1970 Jaeschke ..... D13/122

D236,985 S \* 9/1975 Baumann ..... D13/114  
D245,499 S \* 8/1977 Andreas ..... D13/112  
D578,063 S \* 10/2008 Lannoch ..... D13/112  
D593,945 S \* 6/2009 Lannoch ..... D13/122  
D795,808 S \* 8/2017 Mayor ..... D13/122  
D883,928 S \* 5/2020 Lust ..... D13/112  
D909,973 S \* 2/2021 Stockton ..... D13/122  
2003/0230942 A1 \* 12/2003 Okubo ..... H02K 11/33  
310/89

\* cited by examiner  
*Primary Examiner* — Derrick E Holland  
(74) *Attorney, Agent, or Firm* — PEARNE & GORDON  
LLP

(57) **CLAIM**

The ornamental design for a motor, as shown and described.

**DESCRIPTION**

FIG. 1 is a front and left perspective view of a motor, showing our new design.  
FIG. 2 is a rear and right perspective view thereof.  
FIG. 3 is a front elevation view thereof.  
FIG. 4 is a rear elevation view thereof.  
FIG. 5 is a left side elevation view thereof.  
FIG. 6 is a right side elevation view thereof.  
FIG. 7 is a top plan view thereof.  
FIG. 8 is a bottom plan view thereof; and,  
FIG. 9 is an enlarged cross-sectional view taken along the line 9-9 in FIG. 5.  
The broken lines shown in the drawings illustrate portions of the motor that form no part of the claimed design.

**1 Claim, 9 Drawing Sheets**

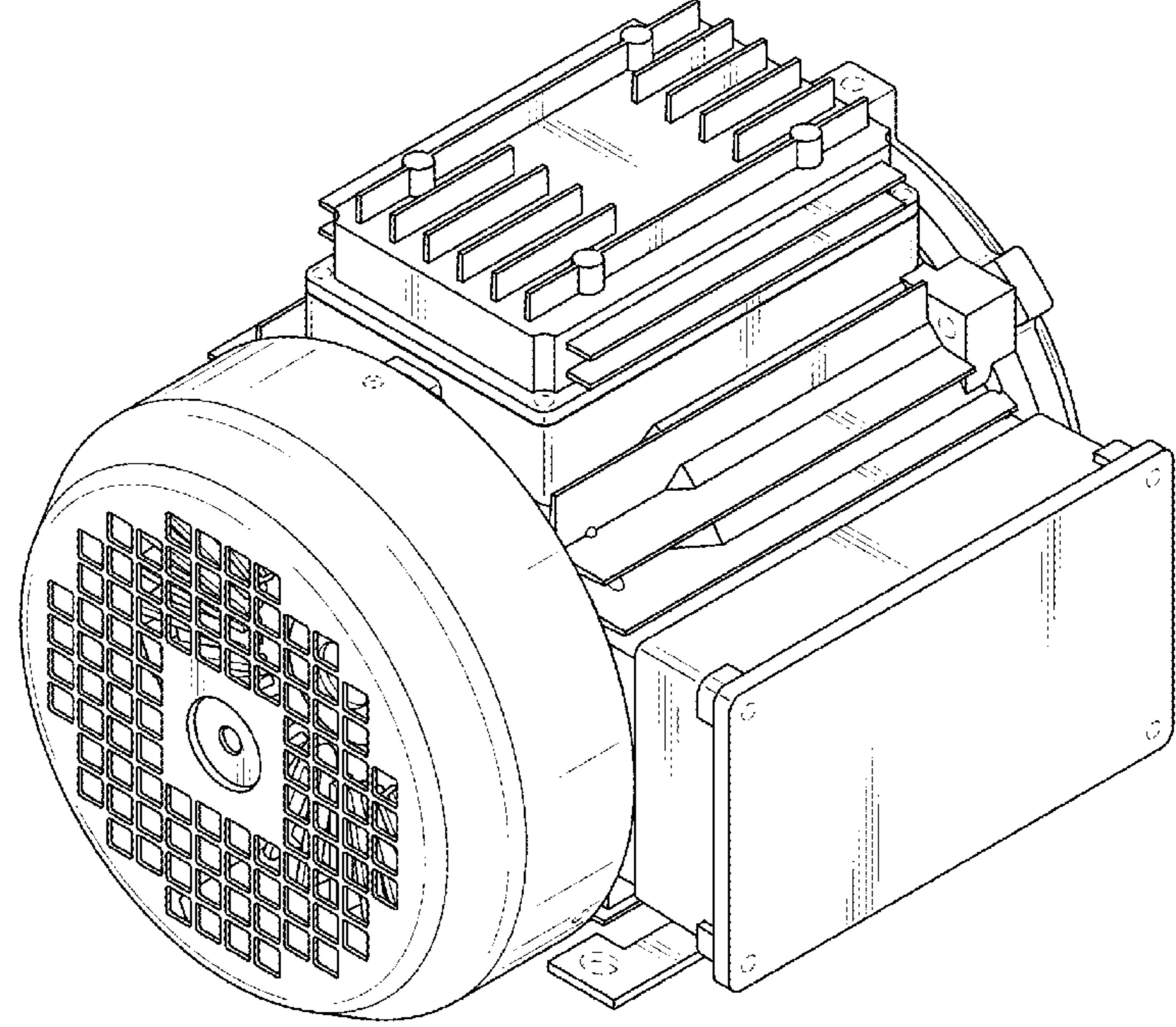

FIG. 1

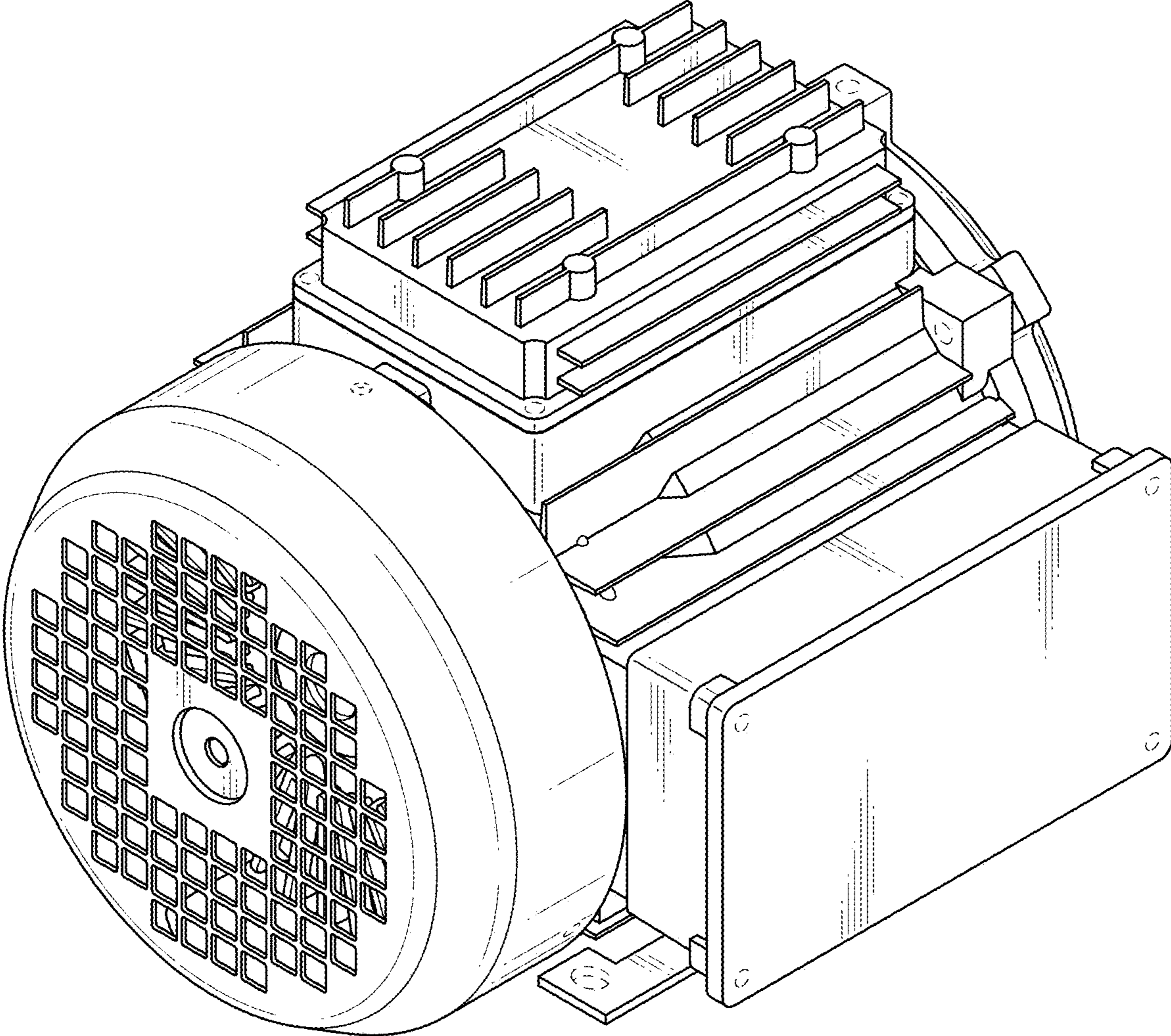



FIG. 2

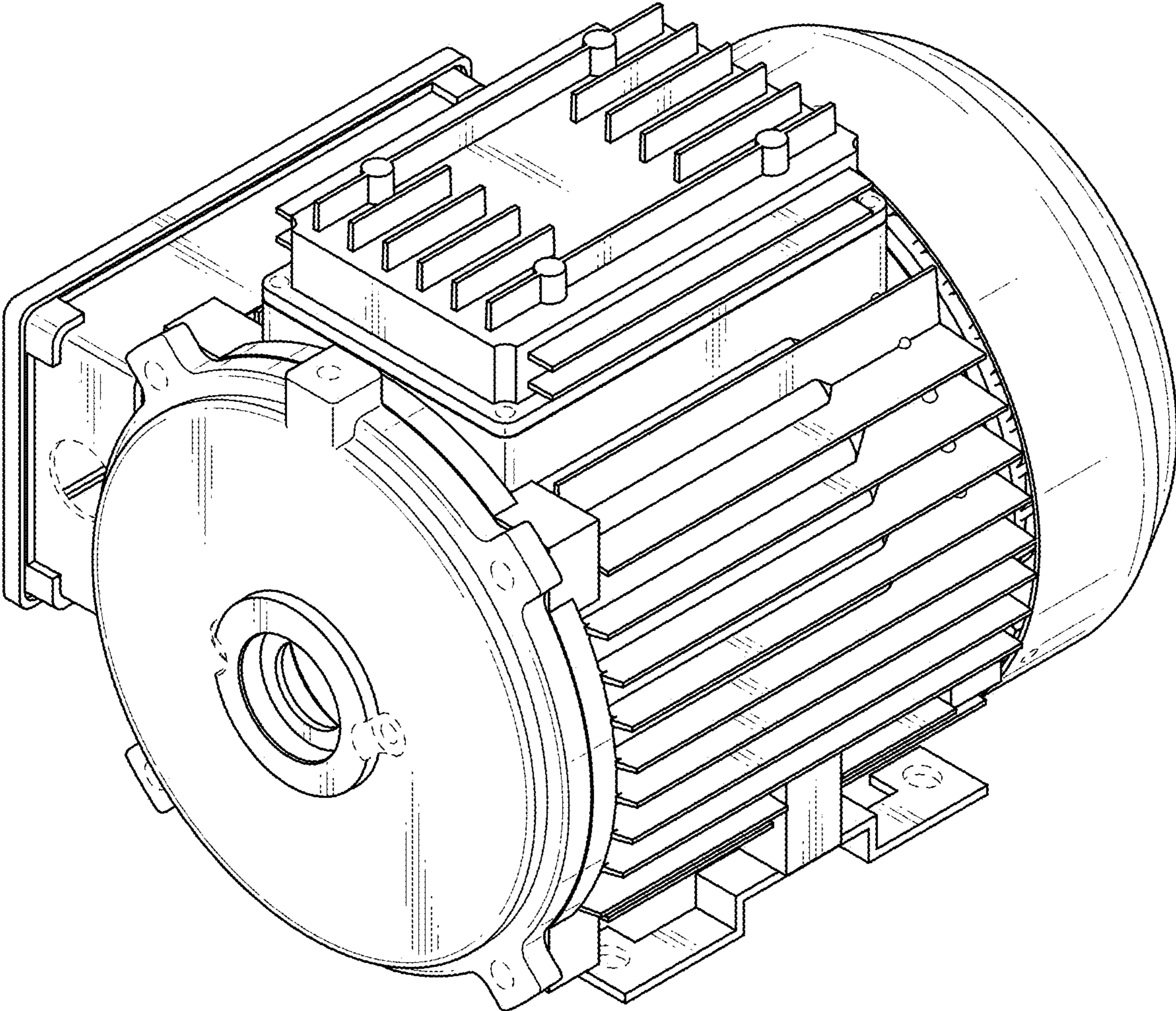

FIG. 3

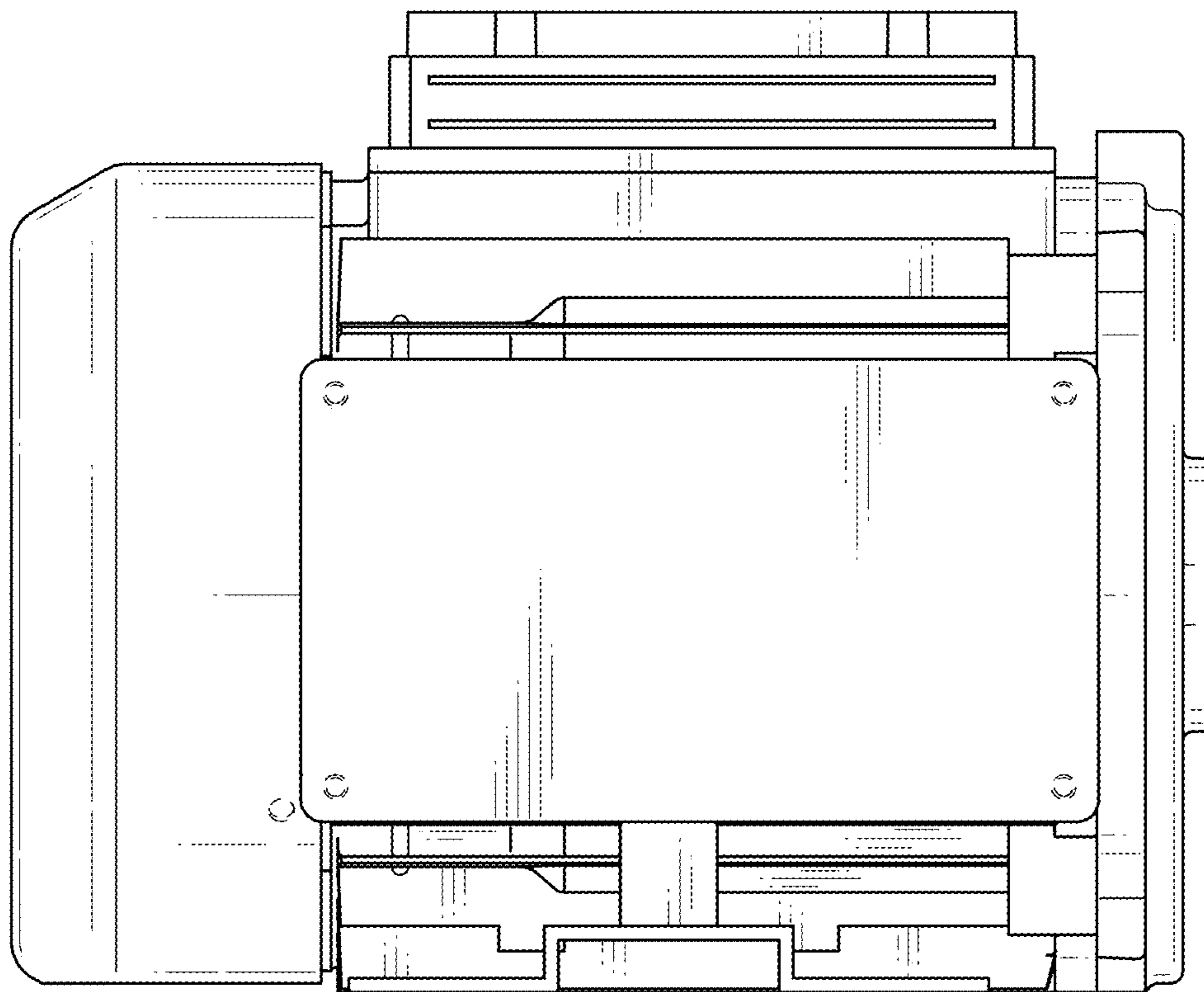

FIG. 4

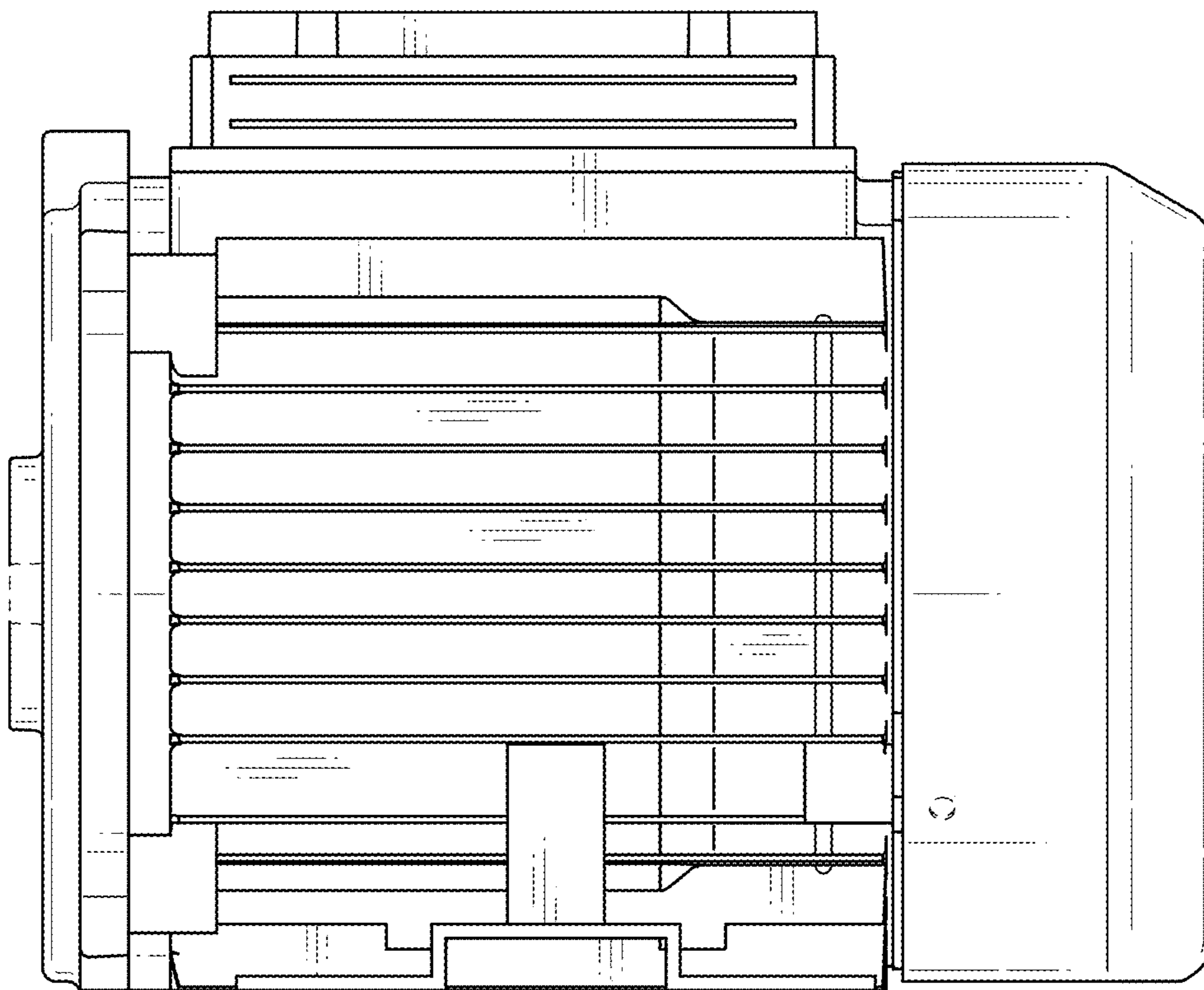

FIG. 5

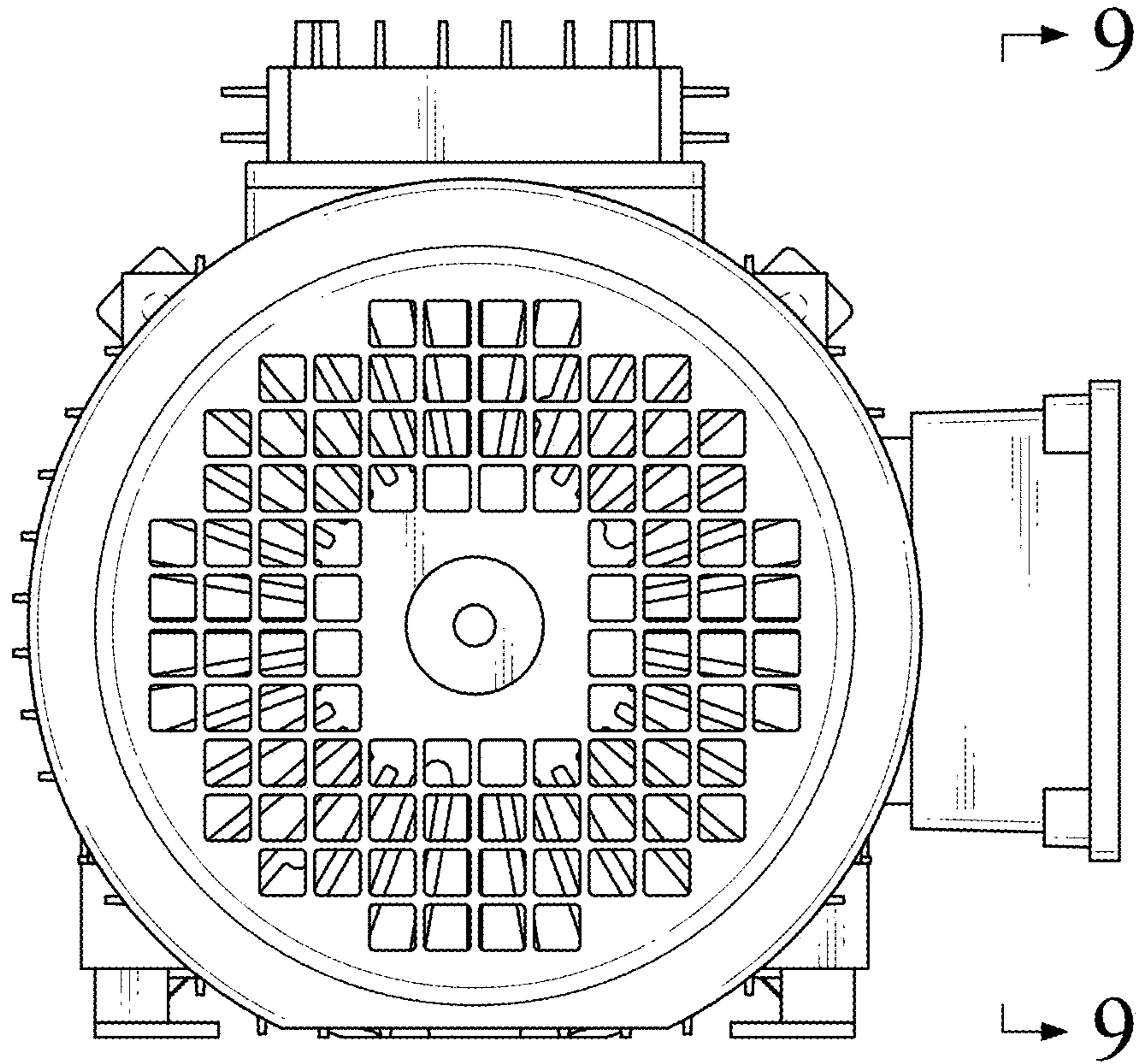

FIG. 6

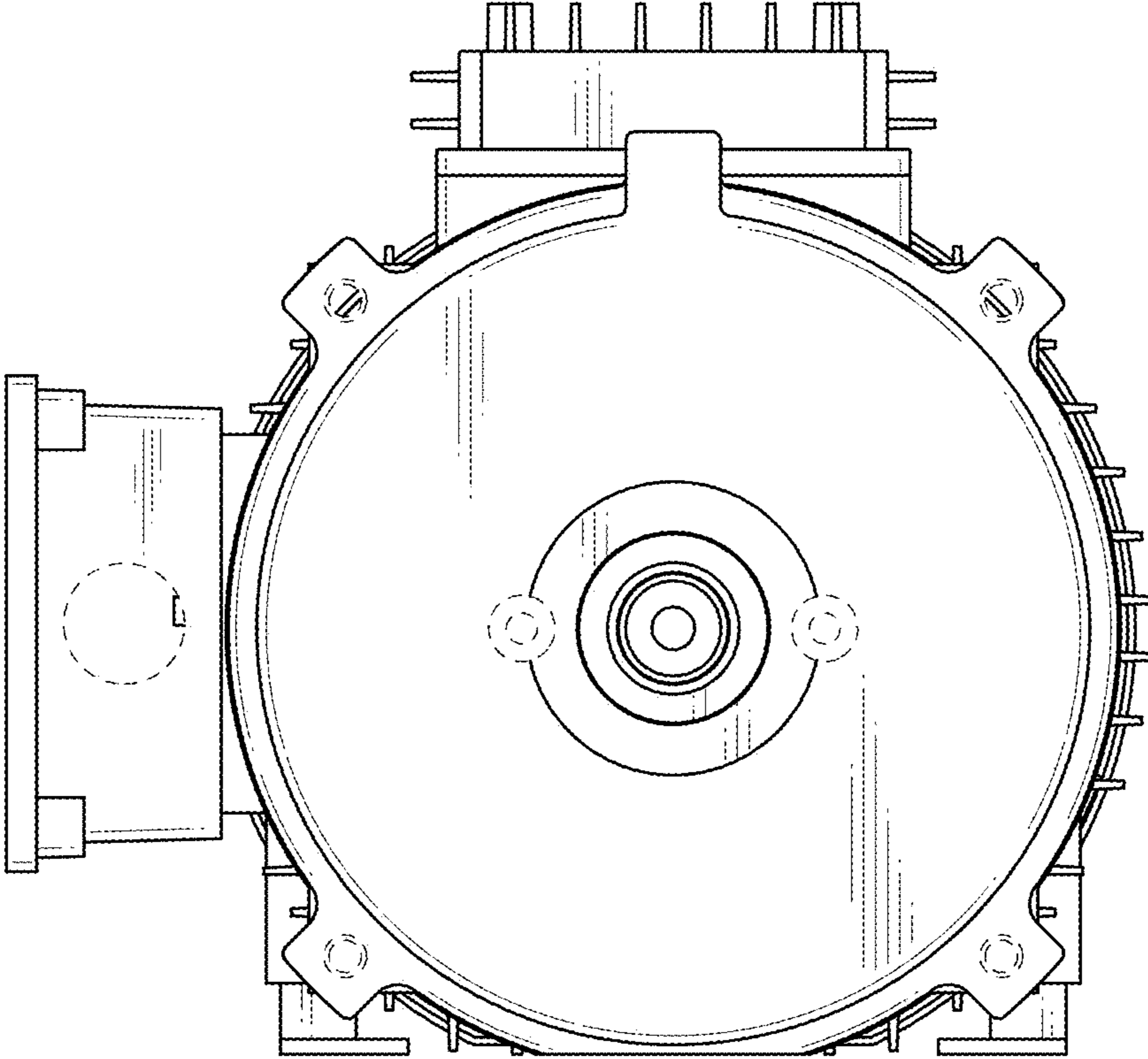



FIG. 7

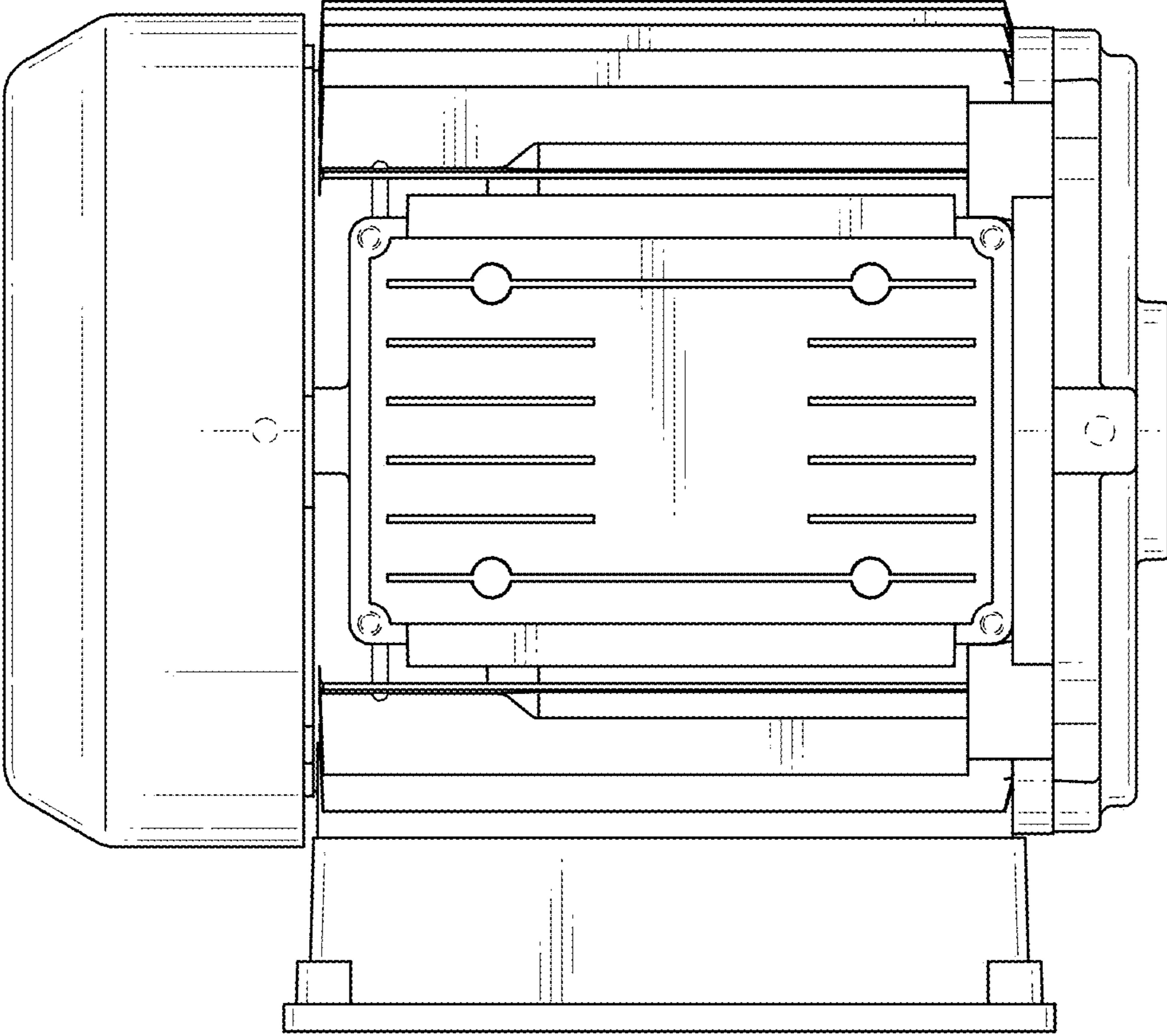



FIG. 8

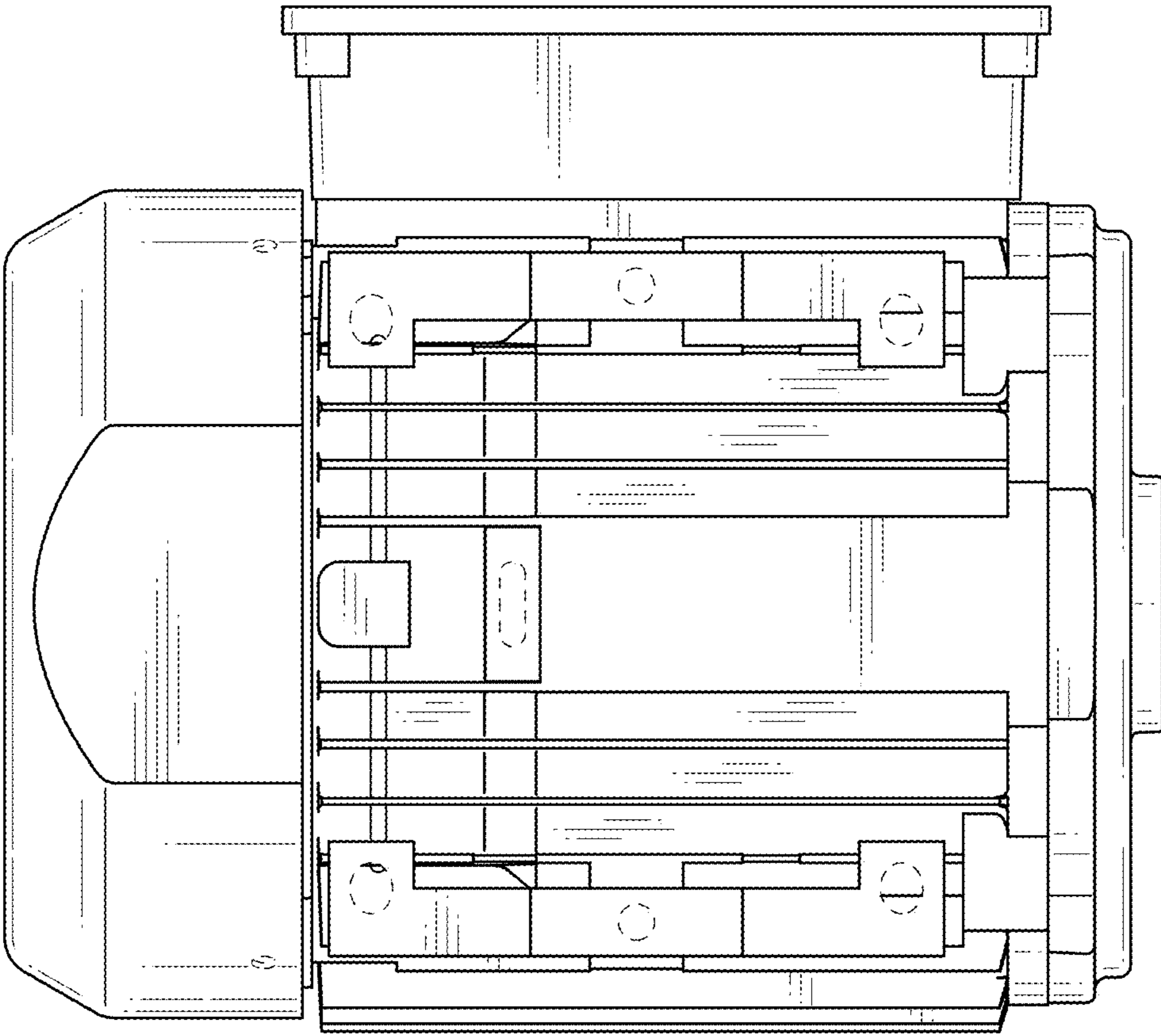

FIG. 9

